

For the most absorbent polymers, the path to purity is crystal clear

Fluid engineering makes the difference.

How do you combine the highest purity with the highest yield? For manufacturers of superabsorbent polymers, the answer is falling film melt crystallization. First pioneered in 1989, this unique crystallization solution now produces 1.8 million tons of glacial acrylic acid every year, or 80% of total world production. That's billions of diapers, personal care products and more, all produced with 99.9% purity to provide the high-performance absorption we rely on every day. Learn how smarter crystallization can make a difference for your manufacturing operations today at Sulzer.com.

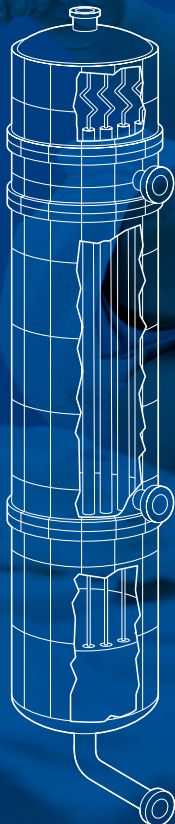

Learn why acrylic acid manufacturers worldwide rely on Sulzer's innovative solvent-free melt crystallization



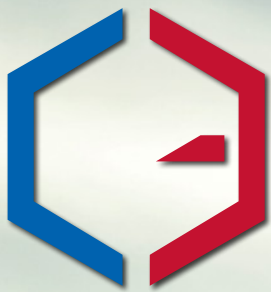

CHEMICAL ENGINEERING

December
2021

ESSENTIALS FOR THE CPI PROFESSIONAL
www.chemengonline.com

Pumps

Column Internals

Cake Filtration

High-Cycle
Valves in RTOs

Motors and Drives

Plant Revamps

page 26

Chemical
Engineering
Buyer's Guide
2022



ENGINEERED-TO-ORDER SOLUTIONS FOR YOUR OPERATIONS



Whatever your industrial challenge, we're the solution.

As a family of industry-leading problem solvers and capability builders, our capabilities span engineering, manufacturing, construction and optimization. Our innovative, custom-built, single-source solutions are skillfully designed for enhanced system performance and to meet specific industrial needs of our customers and partners.

DISCOVER MORE. Visit koch.link/aboutKES or scan the QR code.



Cover Story

26 **Part 1 Unlocking Hydraulic Limits in a Revamp**

Follow the practical tips discussed here to accelerate hydraulic revamp projects and increase the success rate

34 **Part 2 Revamps and Retrofits: A Path to 'Evergreen' Facilities**

An intelligent approach to developing the scope of retrofit projects can allow facilities to remain competitive in the marketplace and meet regulatory requirements



In the News

5 **Chementator**

Structured catalyst improves efficiency and H₂ yields in SMR; Zero-liquid-discharge project to recover products from brine; New catalyst technology for MeOH synthesis boosts production and extends lifetimes; Waste-based ceramics improve energy storage economics; and more

11 **Business News**

Chemours to open new HFO plant in Arkansas; ALPLA starts up HDPE recycling plant in Mexico; Albemarle to build two new lithium-conversion plants in China; ADM and Gevo join forces to produce renewable fuels in the U.S.; Lanxess to sell High Performance Materials business; and more

13 **Newsfront Taking a Holistic Approach to Column Internals**

Combining new and improved high-performance column internals and a whole-system view provides a comprehensive solution with more benefits

26

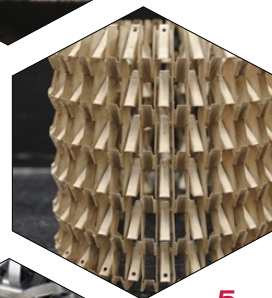

5

Technical and Practical

24 **Facts at your Fingertips Cake Filtration Basics**

This one-page reference provides information on the basic operation and mechanism of cake filtration processes

25 **Technology Profile Production of Citric Acid**

This one-page summary describes the industrial process for generating citric acid via fermentation of corn sugar



13

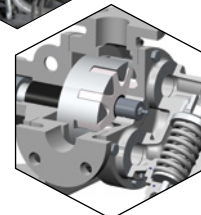

37 **Feature Report Part 1 Gear Pump Basics**

The versatile nature of gear-pump technology allows operators to handle multiple fluids in multiple applications

37

40 **Feature Report Part 2 Pump Seals to Manage**

Water Paying attention to the seal design used in centrifugal pumps can help in water management. This article uses the beverage industry to illustrate this point



21



42



17

42 **Environmental Manager** Critical Components in Regenerative Thermal Oxidizers: High-Cycle Valves

When designing a regenerative thermal oxidizer, engineers should not overlook the high-cycle valves that control process air and help maintain efficiency

Equipment and Services

17 **Focus** Motors and Drives

A new coupling increases performance of predecessor; Users can operate this speed starter intuitively; These motors now have integrated ProfiNet interface; New coating enables boost in efficiency of electric motors; and more

19 **Applied Technologies** Leveraging Time-Series Data to Empower Process Experts

Using new analytics technologies to address process challenges and improve production makes good business sense

21 **New Products**

Digitize weighing processes with this balance software; Bringing artificial intelligence to asset-performance management; Web-based platform streamlines molecule discovery chemistry; and more

Departments

4 **Editor's Page** Climate change on the world stage

As world leaders work on policies to reduce greenhouse gas emissions, technology advances toward making those goals a reality

112 **Economic Indicators**

Advertisers

45 **Hot Products**

46 **2022 Chemical Engineering Buyer's Guide**

109 **Classified Ads**

110 **Subscription and Sales Representative Information**

111 **Ad Index**

Chemical Connections



Follow @ChemEngMag on Twitter



Join the *Chemical Engineering Magazine* LinkedIn Group



Visit us on www.chemengonline.com for more articles, Latest News, New Products, Webinars, Test your Knowledge Quizzes, Bookshelf and more



For content related to COVID-19 and the CPI, visit www.chemengonline.com/covid-19/

Coming in January

Look for: **Feature Reports** on Data Utilization; and Process Safety; A **Focus** on Valves; A **Facts at your Fingertips** on Packaging; a **Newsfront** on Kirkpatrick Award Honorees; **New Products**; and much more

Cover design:
Tara Bekman

ARKEMA

FOR THE WORLD TO CHANGE, WE MUST CHANGE THE MATERIALS WE USE.

In the race to transition to a more sustainable world, you can rely on our innovative materials. At Arkema, we team up with the biggest brands, for the greatest champions, to create materials that combine athletic performance with environmental responsibility, like shoe soles created from organic and recyclable sources. Arkema makes sports better by ensuring innovation and responsibility always go hand in hand.

Arkema. Innovative materials for a sustainable world.

arkema.com

For details visit adlinks.chemengonline.com/80076-02

EDITORS

DOROTHY LOZOWSKI

Editorial Director
 dlozowski@chemengonline.com

GERALD ONDREY (FRANKFURT)

Senior Editor
 gondrey@chemengonline.com

SCOTT JENKINS

Senior Editor
 sjenkins@chemengonline.com

MARY PAGE BAILEY

Senior Associate Editor
 mbailey@chemengonline.com

GROUP PUBLISHER

MATTHEW GRANT

Vice President and Group Publisher,
 Energy & Engineering Group
 mattg@powermag.com

AUDIENCE

DEVELOPMENT

JOHN ROCKWELL

Managing Director, Events & Marketing
 jrockwell@accessintel.com

JENNIFER McPHAIL

Marketing Manager
 jmcphail@accessintel.com

GEORGE SEVERINE

Fulfillment Manager
 gseverine@accessintel.com

DANIELLE ZABORSKI

List Sales: Merit Direct, (914) 368-1090
 dzaborski@meritdirect.com

ART & DESIGN

TARA BEKMAN

Graphic Designer
 tzaino@accessintel.com

PRODUCTION

GEORGE SEVERINE

Production Manager
 gseverine@accessintel.com

INFORMATION SERVICES

CHARLES SANDS

Director of Digital Development
 csands@accessintel.com

CONTRIBUTING EDITORS

SUZANNE A. SHELLEY

sshelley@chemengonline.com

PAUL S. GRAD (AUSTRALIA)

pgrad@chemengonline.com

TETSUO SATOH (JAPAN)

tsatoh@chemengonline.com

JOY LEPREE (NEW JERSEY)

jlepre@chemengonline.com

EDITORIAL ADVISORY BOARD

JOHN CARSON

Jenike & Johanson, Inc.

JOHN HOLLMANN

Validation Estimating LLC

DAVID DICKEY

MixTech, Inc.

HENRY KISTER

Fluor Corp.

HEADQUARTERS

40 Wall Street, 16th floor, New York, NY 10005, U.S.
 Tel: 212-621-4900
 Fax: 212-621-4694

EUROPEAN EDITORIAL OFFICES

Zeilweg 44, D-60439 Frankfurt am Main, Germany
 Tel: 49-69-9573-8296
 Fax: 49-69-5700-2484

CIRCULATION REQUESTS:

Tel: 800-777-5006
 Fax: 301-309-3847
 Chemical Engineering, 9211 Corporate Blvd.,
 4th Floor, Rockville, MD 20850
 email: clientservices@accessintel.com

ADVERTISING REQUESTS: SEE P. 110

CONTENT LICENSING

For all content licensing, permissions, reprints, or e-prints, please contact
 Wright's Media at accessintel@wrightsmedia.com or call (877) 652-5295

ACCESS INTELLIGENCE, LLC

DON PAZOUR

Chief Executive Officer

JONATHAN RAY

Vice President, Digital

HEATHER FARLEY

Chief Operating Officer

MICHAEL KRAUS

Vice President,
 Production, Digital Media & Design

JOHN B. SUTTON

Executive Vice President
 & Chief Financial Officer

TINA GARRITY

Senior Director, Financial Planning
 & Analysis

MACY L. FECTO

Chief People Officer

DANIEL J. MEYER

Corporate Controller

JENNIFER SCHWARTZ

Senior Vice President & Group Publisher
 Aerospace, Energy, Healthcare



9211 Corporate Blvd., 4th Floor
 Rockville, MD 20850-3240
 www.accessintel.com

ROB PACIOREK

Senior Vice President,
 Chief Information Officer



Climate change on the world stage

At the time of this writing, COP26 is underway in Glasgow, Scotland. COP26 is the 26th Conference of the Parties to the United Nations Framework Convention on Climate Change. Since the start of the first COP in 1995, climate change has evolved into a more urgent global priority. In 2015, a milestone was reached at COP21 when over 190 countries adopted the Paris Agreement and committed to lower greenhouse gas emissions in order to limit the rise in global temperatures to less than 2°C (with a target of 1.5°C), above pre-industrial temperatures. At that time, countries agreed to update their plans every five years — which, due to a pandemic delay, is this year.

And while progress has been made, according to the organizers of COP26, the world is currently not on track to meet the goals of the Paris Agreement, and much more must be done to avoid the continued escalation of catastrophic weather events.

Greenhouse gases

Greenhouse gases (GHG) are so-named because they trap heat in the earth's atmosphere. Of the four most-concerning ones — carbon dioxide, methane, nitrous oxide and fluorinated gases — focus has been given to reducing CO₂ and CH₄. According to the U.S. Environmental Protection Agency (EPA; www.epa.gov), CO₂ accounted for about 80% of all anthropogenic U.S. GHG emissions in 2019.

And while CH₄ emissions accounted for only 10% of those emissions, methane is more efficient at trapping radiation and is estimated to have about a 25 times higher impact than CO₂ on a weight basis over a 100-yr period. The Global Methane Pledge, first proposed in September and strengthened by an announcement of a global partnership at COP26, aims to reduce CH₄ emissions by 30% from 2020 levels by 2030. Over 100 countries have signed the pledge.

Technology advances

The chemical process industries (CPI) have been increasingly committed to ambitious climate-change goals. And with policies supporting such goals, more opportunities for technological advances are expected. Most recently, ExxonMobil stated that it plans to invest more than \$15 billion over the next six years to lower GHG emissions. The company cites carbon capture and storage as a key technology to help reach net zero emissions goals by 2050. It also cites biofuels and hydrogen as areas with opportunities for significant emissions reductions.

And while many are working on an economical pathway to “green” hydrogen via electrolysis, advances to increase energy efficiency in the traditional steam-methane reforming process to reduce CO₂ emissions are also being pursued. Two such advances are detailed on p. 5 of this issue.

Countless activities supporting emissions reductions are underway in the scientific community. Challenges and advances in column use for carbon capture, for example, are outlined in our Newsfront on p. 13. A technique for combustion-free abatement of methane emissions was described in our November issue's Chementator section (p. 5).

As policies and company goals continue to point toward a sustainable future, innovation and sound engineering will help to make those goals a reality. We will continue to cover those advances in these pages, on our website and at our events. ■

Dorothy Lozowski, Editorial Director



Structured catalyst improves efficiency and hydrogen yields in SMR . . .

Commissioning has begun on a pilot plant designed to demonstrate the effectiveness of a structured catalyst module for steam-methane reforming (SMR) that solves the main heat-transfer inefficiencies associated with the conventional process. The structured catalyst technology improves the efficiency of SMR and increases the hydrogen produced.

Steam reforming of methane — an endothermic reaction typically carried out in multi-tube, fixed-bed reactors filled with catalyst-laden ceramic pellets — is subject to heat-transfer inefficiencies due to the size and random placement of the pellets.

“Heat transfer in SMR reactors depends in large measure on feed gas impinging the boundary layer of fluid at the tube wall,” explains Bruce Boisture, president and co-founder of ZoneFlow Reactor Technologies, LLC (Windsor, Conn.; www.zoneflowtech.com), the developer of the new SMR technology. “But that heat-transfer mechanism is not optimized in the reactor tubes because of the random packing of the pellets in the reactor and their relatively large size (a concession to durability concerns) in relation to the diameter of the reactor tube. The result is a random gas-flow pattern within the reactor, sub-optimal heat transfer into the reactor and pressure drop across the reactor, and a significant amount of methane that can ‘bypass’ the catalyst along the tube walls. This high-temperature, but unreacted methane can cause coke buildup on the pellets.”

The ZoneFlow structured catalyst (photo) features precisely engineered flow channels in its outer casing that are designed to force the methane to contact the tube wall while minimizing pressure drop. The geometry of its support structure keeps the catalyst-coated casing in continuous contact with the tube wall despite tube creep, eliminating bypass, Boisture comments. “In testing, heat-transfer efficiency was improved by 100% while maintaining the same pressure drop,” Boisture says, which translates into an expected 15% higher throughput compared to conventional catalyst systems.

ZoneFlow’s pilot plant, located at the Université Catholique de Louvain (Belgium), is undergoing final commissioning now, and the plant will start up by the end of 2021. Pilot testing results are expected in mid-2022. In early November, ZoneFlow announced a joint development agreement with Honeywell UOP (Des Plaines, Ill.; www.uop.com) to develop and commercialize the technology. Honeywell says the ZoneFlow reactor technology allows capital savings for new SMR plants and higher productivity for existing plants, and the opportunity to reduce steam requirements for SMR will reduce energy demand and CO₂ emissions.

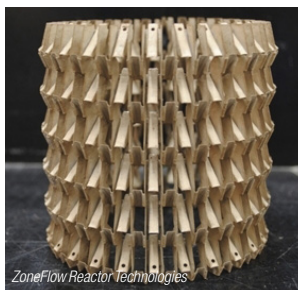

Edited by:
Gerald Ondrey

FLOW BATTERY

Honeywell Inc. (Charlotte, N.C.; www.honeywell.com) introduced a new flow-battery technology that employs a proprietary electrolyte to provide reliable extended-duration energy storage — up to 12 h compared to lithium-ion batteries’ (LIBs) 4 h. “The flow battery uses a non-flammable, water-based electrolyte and will not succumb to failure mechanisms like thermal runaway, unlike LIBs, which rely upon organic electrolytes,” says Roopa Shortt, business development director, Honeywell Sustainable Technology Solutions.

The battery operates by reducing and oxidizing active species in the aqueous electrolyte upon charge and discharge of the battery. “We have developed ways to improve the speed and electrical efficiency of both charging and discharging to ensure stability across thousands of cycles. We have also optimized our design to take advantage of lower-cost materials

(Continues on p. 6)

. . . as does this new SMR technology

Meanwhile, a collaboration between Clariant Catalysts (Munich, Germany; www.clariant.com/catalysts) and Technip Energies N.V. (Zoetermeer, the Netherlands; www.technipenergies.com) has led to SMR technology that is said to achieve higher throughput and heat recovery in SMR. Technip Energies’ Enhanced Annular Reforming Tube for Hydrogen (Earth) technology is designed as a drop-in solution, thus it is well suited to both existing and new reformer tubes. It is already in operation in the Akkim hydrogen (HyCO) plant in Turkey since January 2019, which shows excellent and stable performance, 20% less CO₂ emissions and nearly 40% lower fossil fuel consumption — all at equal H₂ and CO output, says Clariant. Clariant and Technip Energies have also been awarded two further contracts for Earth: a 21,000-Nm³/h H₂ plant for Repsol, which will start up in February 2023 in Cartagena, Spain; and a second for an upgrade of an existing European H₂ plant.

Earth technology, developed and patented by Tech-

nip Energies, comprises a concentric tubular assembly in the SMR with a structured catalyst loaded in the outer annular space. The proprietary geometric layout, in combination with highly active, stable and mechanically robust catalyst — jointly developed by Clariant and Technip Energies — offers low pressure drop, maximum activity and heat transfer, despite the thermal and mechanical stress of the reforming process and the reduced volume of the Earth catalyst bed.

While traditional SMR technologies degrade high-grade process heat to generate high-pressure steam, Earth offers the possibility to utilize this heat to produce additional H₂ or to reduce the firing duty of the reformer, thus saving energy (and operating costs), according to Technip Energies. Steam export can be reduced by 50%, compared to conventional technology, the company says.

“[Earth] is a key technology of our BlueH₂ by T.EN suite of solutions to achieve more sustainable hydrogen and syngas production the market has been seeking,” says Stan Knez, chief technology officer at Technip Energies.

than are used in other batteries," adds Shortt. In 2022, Honeywell will deliver a 400-kWh unit to Duke Energy.

NAPHTHA CRACKER

In October, Coolbrook Oy (Helsinki, Finland; www.coolbrook.fi) and its partners started construction at Brightlands Chemelot Campus in Geleen, the Netherlands where the world's first electric steam cracker will be tested and further perfected towards commercialization. As part of the preparations for this pilot, air tests will take place in Finland before the end of this year with the patented Rotor Dynamic Reactor (RDR) technology (*Chem. Eng.*, May 2017, p. 9). The pilot at Brightlands Chemelot Campus will be fully operational in April 2022, after which the technology can be applied on a commercial scale in the near future.

Shell endorses the value of this technology by joining as an industry partner for the pilot project at Brightlands Chemelot Campus. In addition to providing up to 20% more ethylene yield than a traditional cracker, the implementation of the RDR technology leads to a complete reduction in CO₂ emissions, 30% reduction in energy consumption and therefore 60% more profit, the company says. In July, the technology received over €5.5 million in subsidy from the Ministry of Economic Affairs and Climate Policy to enable this pilot to be carried out on an industrial scale.

NEW ALLOY

Sandvik Materials Technology AB (Sandviken, Sweden; www.materials.sandvik.com) recently received the first-ever contract from a renewable diesel plant for its Sanicro 28 high-alloy austenitic stainless steel. The reference order is for the use of Sanicro 28 in the reactor effluent-air coolers (REAC) of the hydroprocessing unit at one of the largest renewable diesel refineries in the U.S. Gulf Coast, due to start production in 2023.

Sanicro 28 is a multi-purpose austenitic stainless steel for service in extremely corrosive conditions. It was originally developed for the fertilizer in-

Zero-liquid-discharge project to recover products from brine

HRS Heat Exchangers Ltd. (Watford, U.K.; www.hrs-heatexchangers.com) was recently awarded an order for the design, manufacture and installation of a mechanical vapor recompression (MVR) evaporation system for LIFE Desirows (lifedesirows.eu) — a three-year, €1.6-million project funded under the E.U.'s LIFE19 program. LIFE Desirows, which involves a consortium of companies and the Polytechnic University of Cartagena (UPCT; Spain; www.upct.es), aims to demonstrate a circular economy, zero-liquid discharge (ZLD) project to improve water quality in the Murcia region of Spain.

The consortium has developed a process (diagram) that removes nutrients and separates different salts from agricultural brine, so that they can be used as fertilizers. First, a double reverse-osmosis (RO) process generates a second brine, which then undergoes denitrification and chemical precipitation processes to remove the nutrients and the salts. The resulting solution is then thermally concentrated using a cooling tower and MVR to produce a saturated solution. Finally, the precipi-

tated salts are removed from this saturated solution using wind-aided intensified evaporation (WAIE), providing a true zero-liquid discharge solution that converts the environmentally unfriendly brine into clean water for irrigation, fertilizer and salts for industrial use.

MVR evaporation is said to be one of the most economical ways of concentrating waste streams and does not require a thermal energy source. The electrical energy needed to drive the MVR compressor is supplied by photovoltaic solar panels. The evaporation module uses HRS corrugated-tube technology. The corrugated tubes generate extra product turbulence, which provides enhanced heat transfer and also delays heat exchanger fouling.

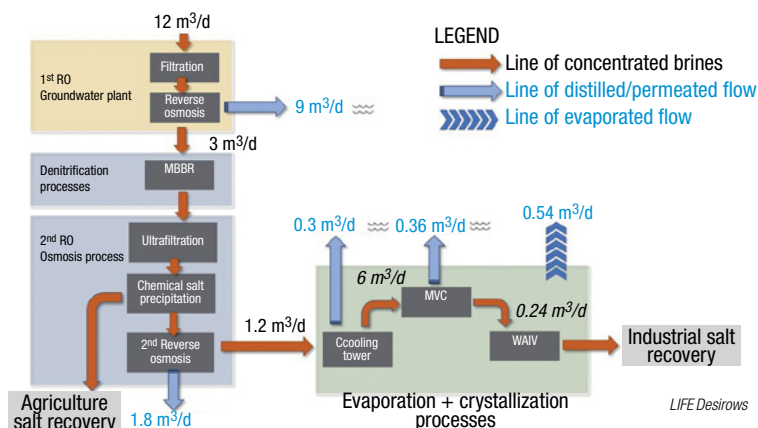

New catalyst technology for MeOH synthesis boosts production and extends lifetimes

Newly launched catalyst technology, developed through a collaboration between Clariant (Muttenz, Switzerland; www.clariant.com) and Air Liquide Engineering & Construction (Frankfurt am Main, Germany; www.engineering-airliquide.com) and designed for methanol (MeOH) production, is capable of boosting cumulative MeOH yields by up to 15% and extending catalyst lifetimes by up to two years. Officially launched in October, the technology is known as MegaZonE, a play on the name of the Clariant catalyst material on which it is based — MegaMax, a series of copper-oxide/zinc-oxide/alumina catalysts used for synthesizing MeOH from synthesis gas (CO and H₂).

Methanol synthesis typically occurs within a fixed-bed reactor, and MegaZonE uses several layers of catalyst material within the reactor that have differing activity levels. Because each catalyst layer is tailored to the specific reaction conditions along the reaction pathway, the layers optimize heat management and catalyst performance. As Clari-

ant explains, catalysts with moderate activity are loaded in hotter zones of the converter to prevent hotspots, while activity-enhanced catalysts are placed further down the reaction pathway to intensify reaction rates in the lower portion of the converter.

"On the one hand, less thermal stress on catalysts will lead to longer catalyst lifetimes. On the other hand, high activity in the bottom part of the reactor will increase reaction rates and reduce byproduct formation by up to 10%," explains Stefan Heuser, senior vice president and general manager at Clariant Catalysts (Munich, Germany).

"MegaZonE is a game-changing technology that will increase customers' profits," says Heuser. "It enables more compact, resilient and longer-lasting designs, and is an example of Clariant's close collaboration with our partner Air Liquide Engineering and Construction," he adds.

MegaZonE was successfully applied to two world-scale methanol plants in Asia this year, and is showing excellent and stable performance, according to Heuser.

(Continues on p. 8)

Size Matters.

With enormous engineering and manufacturing resources — 5 plants in the U.S., 3 in China and 1 in India — Ross can handle the largest mixing challenges imaginable. And deliver anywhere in the world.

Learn how Ross can meet your mixing requirements. Visit Mixers.com.

Call 1-800-243-ROSS. Or try our free online Knowledge Base & Product Selector web app at Mixers.com/web-app.



Imagine the Possibilities



Scan to learn more.

For details visit adlinks.chemengonline.com/80076-03

dustry and has been successfully used in the upstream oil-and-gas industry for many years. It offers excellent resistance to pitting corrosion and stress-corrosion cracking in high-chloride-bearing environments, making it an effective alternative to high-nickel alloys, such as alloy 825.

The alloy's breakthrough into renewable energy comes after two years of intense data generation that demonstrates Sanicro 28 also offers the corrosion and mechanical properties needed for the refining industry.

MECHANICAL ROUTE TO CLINKER

Portland cement — the binder used in concrete — contains ground cement clinker (calcium silicates and aluminates) that is produced by the high-temperature calcination of limestone and other components. This energy-intensive process generates one ton of CO₂ for every ton of cement produced. As a result, cement production is said to account for approximately 8% (or 2.7 billion ton/yr) of anthropogenic CO₂ emissions worldwide.

In a new study to find “greener” routes to cement production, chemists at the Johannes Gutenberg University Mainz (Germany; www.uni-mainz.de) have developed a method that produces cement clinker using ball mills at ambient temperature, instead of using calcination kilns operating at 1,000–1,500°C. Although the process is still in its infancy and limited to the laboratory scale, the method has the potential to drastically reduce CO₂ emission from cement production.

In the process, which is described in *Advanced Functional Materials* published last month, the raw lime (CaCO₃) is no longer converted into burnt lime in coal-fired kilns, but is simply milled with solid sodium silicate (Na₂SiO₃). This milling step produces an “activated” intermediate that contains the constituents of the cement in uniform distribution. When reacted with sodium hydroxide solution, a product is formed that is structurally similar to the calcium silicate hydrates. The formation of the cement paste and the setting with water proceed via a complex reaction cascade. The reaction mechanism for the multistep salt metathesis reaction were elucidated using x-ray and other analytical methods, in collaboration with researchers from the Gottfried Wilhelm Leibniz University (Hannover) and the Technical University of Darmstadt.

The researchers roughly estimate that the mechanical energy needed for the milling process (120 kWh/ton) is approximately 10% of the energy needed for the calcination process.

NEW YEAST

Novozymes North America Inc. (Franklinton, N.C.; www.novozymes.com) has recently introduced Innova Quantum, a new addition to its Innova yeast platform. With the new yeast, producers can increase ethanol yield by 2–3% compared to predecessor Innova

Mining REEs from phosphogypsum . . .

Last month, the Pennsylvania State University (Penn State; University Park, Pa.; www.psu.edu), Case Western Reserve University (Cleveland Ohio; www.case.edu) and Clemson University (S.C.; www.clemson.edu) received a \$1.7-million National Science Foundation grant for a four-year project to recover rare earth elements (REEs) from phosphogypsum.

Phosphogypsum is formed when phosphate rock is processed into fertilizer, and contains small amounts of naturally occurring radioactive elements, such as uranium and thorium. Because of this radioactivity, the byproduct is stored indefinitely, and improper storage can contaminate soil, water and the atmosphere. “Today, an estimated 200,000 tons of rare earth elements are trapped in unprocessed phosphogypsum waste in Florida alone,” according to Lauren Greenlee, associate professor of chemical engineering and leader of the Penn State effort along with co-principal investigator Rui Shi, assistant professor of chemical engineering. “This source of rare earth elements is presently untapped due to challenges associated with radioactive species and the difficulty of separating the individual elements,” she says. “The vision for this project is to discover new sepa-

ration mechanisms, materials and processes to recover valuable resources, including rare earth elements, fertilizers and clean water, from waste streams of the fertilizer industry, paving the way for a sustainable domestic supply of rare earth elements and a sustainable agriculture sector.”

To harvest the REEs trapped in phosphogypsum, the researchers propose a multistage process using engineered peptides capable of precisely identifying and separating out the rare earth elements through a specialized membrane. “Individual rare earth elements have similar sizes and identical formal charges, so traditional membrane separation mechanisms are insufficient,” Greenlee says. “A key technical goal of this research is to discover the mechanisms that underpin peptide-ion selectivity and leverage those mechanisms to design a new class of highly selective membranes.” Researchers from Case Western will develop the engineered peptides, guided by computational modeling work performed at Clemson.

The proposed project will also complement other Penn State research, including work using naturally occurring protein molecules to extract grouped rare earth elements from other industrial waste sources (see next story).

. . . and from unconventional sources

In October, researchers from Penn State and the Lawrence Livermore National Laboratory (LLNL; Calif.; www.llnl.gov) described — in an article published in *ACS Central Science* — a new method that improves the extraction and separation of rare earth elements (REEs) from unconventional sources, including industrial waste, such as mine tailings and electronic waste. “In this study, we demonstrate a promising new method using a natural protein that could be scaled up to extract and separate rare earth elements from low-grade sources, including industrial wastes,” according to Joseph Cotruvo Jr., assistant professor and Louis Martarano Career Development Professor of Chemistry at Penn State, a member of Penn State’s Center for Critical Minerals, and co-corresponding author of the study.

The new method takes advantage of a bacterial protein called lanmodulin (LanM), previously discovered by the research team, that is almost a billion

times better at binding to REEs than to other metals. The protein is first immobilized onto tiny beads within a column to which the liquid source material is added. The protein then binds to the REEs in the sample, which allows only the rare earths to be retained in the column and the remaining liquid drained off. Then, by changing the conditions (for example, by changing the pH or adding additional ingredients), the metals can be released from the protein for recovery. By carefully changing the conditions in sequence, REEs could be selectively separated.

The researchers first demonstrated that the method is “exceptionally good” at separating the REEs from other metals. They were also able to separate yttrium from neodymium — both abundant in primary rare-earth deposits and coal byproducts — with greater than 99% purity; and neodymium from dysprosium with greater than 99.9% purity in just one or two cycles, depending on the initial metal composition.

(Continues on p. 9)

Waste-based ceramics improve energy-storage economics

Ceramic materials' high heat resistance makes them a promising media for thermal energy storage, but their high costs have inhibited their widespread use for this application. Now, a new technology offered by Ceramic Materials Ltd. (Masdar City, U.A.E.; www.seramic.eco) can efficiently convert a wide range of industrial solid waste materials, such as steel slag and incinerator ash, into ceramic products used for energy storage and construction. "On average, our products are up to 50% cheaper than conventional ceramics, and the carbon footprint can be reduced by up to 60% when compared to materials like alumina, which require energy-intensive extraction and transport of bauxite raw materials. We replace those with locally generated wastes that are always available," says Nicolas Calvet, CEO of Ceramic Materials.

The key to Ceramic Materials' technology is a patented method of mixing different waste streams and fine-tuning process characteristics to yield a specific end-product formulation. "There is great variability in the waste composition, based on

industrial source and geography, meaning that we have to readjust our process and formulation and tune the firing temperature before launching production," explains Calvet. These proprietary analyses take place in Ceramic Materials' dedicated laboratory, where characteristics such as water absorption and compression resistance are precisely tuned to optimize product formulation. Since the main production process uses conventional equipment, Ceramic Materials is partnering with existing ceramics factories to utilize their facilities during periods of inactivity, which significantly lowers capital expenditures.

The company has recently commercialized a technical ceramic product called ReThink Ceramic — Flora, which can reach temperatures as high as 1,250°C, making it ideal for use in concentrated solar-power (CSP) installations. Ceramic Materials has manufactured 30 tons of Flora at a plant in Europe, and projects deploying the material are in development in Spain and the U.S. Work is also underway for a workshop in Abu Dhabi to produce 20,000 m²/yr of sustainable architectural tiles.

Force. For a 100-million-gal/yr plant, this translates to an additional \$1–2 million in revenue, says Novozymes. Designed to operate in fermentations >60 h, Quantum with new strain development is capable of converting the most sugar to ethanol while significantly lowering fermentation by-products such as glycerol up to 40% — all without the trade-off and risk of robustness loss experienced with competing yeasts. And, Quantum expands plant flexibility by fermenting to ethanol concentrations of more than 16% w/v, while eliminating the need for expensive nutritional supplements, says Novozyme.

PHOTOSENSITIZER

Researchers from the Tokyo Institute of Technology (Tokyo Tech;

(Continues on p. 10)



 Chemstations™

CHEMCAD process simulation software can't brew the perfect craft beer.

But it can handle your recipe for plant design.

CHEMCAD models your tough chemistry, makes efficient use of your simulation time, and let's you pay for the power you need, when you need it. Contact us today for a free trial.

ChemE's HAVE A NEW SUPER HERO.

Discover **CHEMCAD NXT** — The evolution of simulation software

CHEMSTATIONS.COM/CRAFT9

For details visit adlinks.chemengonline.com/80076-04

Japan; www.titech.ac.jp) have developed a new osmium complex that can absorb the entire wavelength range of the visible spectrum. When combined with a ruthenium (II) catalyst, the complex enables the direct reduction of CO₂ into formic acid.

Although Ru complexes are commonly used redox photosensitizers, they do not absorb visible light, whereas alternative panchromatic complexes cannot also be used for photoredox reactions because the lifetimes of their excited states are too short. The Tokyo Tech combination, described in a recent issue of *Chemical Science*, overcomes both hurdles. The osmium complex absorbs all wavelengths in the visible spectrum, and the excited state has a sufficiently long lifetime (40 ns) for initiating electron-transfer processes required for reduction.

When irradiating the combination with 770-nm light, the system photocatalytically reduced CO₂ into formic acid with good reaction turnover numbers. 

A new spin on ultrasonic algae control in wastewater-treatment applications

Ultrasonic treatment is a non-chemical method to control algae using specific sound frequencies emitted through water to cause internal damage to polluting algae cells. Most previous work in the area of ultrasonic algae control has focused on very loud emitted frequencies to create cavitation bubbles that damage the algae cells, but a new line of products from Sonic Solutions Algae Control LLC (Northampton, Mass.; www.sonicsolutionsllc.com) and WaterIQ Technologies (Wilson, Wyo.; www.wateriqtech.com) emits over 2,000 different frequencies on two bandwidths to take advantage of critical structural resonance (CSR), the specific frequency that ruptures the vesicles within algae cell walls. The damaged algae cells lose their buoyancy or have torn inner cell walls, causing them to naturally decompose due to lack of sunlight or damaged functions. Launched in October at Weftec, The Pulsar 4000 and 3000 models are said to be

360-deg, CSR-based ultrasonic coverage in ponds, reservoirs and clarifier tanks.

“When you emit frequencies at an object’s CSR, the object begins to vibrate, and if the frequency is strong enough, the object can damage itself with shearing vibration,” explains George Hutchinson, chief technology officer and vice president of operations at Sonic Solutions Algae Control. A benefit of CSR-based control over cavitation is lower power consumption and longer distance coverage. “To use cavitation to damage algae several hundred meters away, the device has to create almost an explosive surge to create cavitation at that distance. Our devices stay well below the cavitation threshold,” says Hutchinson.

Furthermore, the wide range of frequencies emitted by the devices enable them to mitigate over 90% of different algae species encountered in wastewater treatment plants, agricultural farms and more. The key to tapping into so many frequencies is a specially designed piezo transducer head and microprocessor. 

Change the
status quo
with

Glyclean™ D
Clean & Disinfect

~~QUAT~~

**Tired of the trade-offs
associated with
traditional disinfectants?**

Meet Glyclean™ D. Newly approved for killing SARS-CoV-2 (COVID-19), this safe solution relies on glycolic acid, nature’s own preservative and protector. It’s more effective, efficient, and environmentally responsible.

In a world where quickly killing viruses, bacteria, and germs is a global imperative, Glyclean D ticks all the boxes. Unlike harsh, corrosive chemicals or quats, Glyclean D is people- and planet-friendly—and it’s EPA approved.

Learn more at pages.chemours.com/GlycleanD.



For details visit adlinks.chemengonline.com/80076-05

Plant Watch

Chemours to open new HFO plant in Arkansas

November 11, 2021 — The Chemours Co. (Wilmington, Del.; www.chemours.com) announced plans to open a new facility located in El Dorado, Ark. The new plant will be dedicated to Chemours' Opteon1150 hydrofluoroolefin (HFO), chemically referred to as HFO-1336mzzE.

ALPLA starts up HDPE recycling plant in Mexico

November 11, 2021 — ALPLA Group (Hard, Austria; www.alpla.com) has opened a new recycling plant for high-density polyethylene (HDPE) plastic in Toluca, Mexico. The facility is currently designed for a capacity of 15,000 metric tons per year (m.t./yr) of recycled HDPE (rHDPE) in pellet form, and the company has announced plans to double the annual regrind production capacity to 30,000 m.t./yr in the second half of 2022. The investment in the new plant was around €20 million.

Honeywell commercializes new recycling technology, will build plant in Spain

November 3, 2021 — Honeywell International Inc. (Charlotte, N.C.; www.honeywell.com) has launched a new chemical recycling technology for plastic waste, and will commercialize this technology at a new plant in Spain. Honeywell and engineering firm Sacyr S.A. (Madrid, Spain; www.sacyr.com) will jointly co-own and operate the facility in Andalucía with a capacity to transform 30,000 m.t./yr of mixed waste plastics into recycled polymer feedstock. Production is expected to begin in 2023.

Nouryon to increase colloidal silica manufacturing plant in Wisconsin

November 2, 2021 — Nouryon (Amsterdam, the Netherlands; www.nouryon.com) plans to expand production capacity at its Levasil colloidal-silica manufacturing facility in Green Bay, Wis. to meet increasing demand from the construction and packaging markets. Construction of the facility expansion is planned to be finalized in the second half of 2022.

Elkem to expand specialty-silicone production plant in France

October 27, 2021 — Elkem ASA (Oslo, Norway; www.elkem.com) will invest around €36 million to upgrade and debottleneck its specialty-silicone upstream plant in Roussillon, France, resulting in a 20,000-m.t./yr capacity expansion. This brings the site's capacity to 100,000 m.t./yr of effective silicone intermediates for end uses including semiconductors, 3D printing and medical devices. The expansion is anticipated to come online during the third quarter of 2023.

Evonik expands specialty silica production in Japan

October 25, 2021 — DSL Japan, a joint venture of Evonik Industries AG (Essen, Germany; www.evonik.com) and Japanese pharmaceutical firm Shionogi, has opened a new production line for specialty silicas at the company's site in Ako, Japan. The new capacities expand the overall production capacity of custom silica solutions by 30%.

ADM and Gevo join forces to produce renewable fuels in the U.S.

October 28, 2021 — Archer-Daniels-Midland Co. (ADM; Chicago; www.adm.com) and Gevo, Inc. (Englewood, Colo.; www.gevo.com) have signed a memorandum of understanding (MoU) to support the production of both ethanol and isobutanol that would then be transformed into renewable hydrocarbons, including sustainable aviation fuel (SAF), using Gevo's processing technology and capabilities. About 900 million gal of ethanol produced at ADM's facilities in Columbus, Neb., Cedar Rapids, Iowa and Decatur, Ill., are expected to be processed utilizing Gevo technology, resulting in production of approximately 500 million gal of renewable hydrocarbons.

Albemarle to build two new lithium-conversion plants in China

October 22, 2021 — Albemarle Corp. (Charlotte, N.C.; www.albemarle.com) has signed agreements to move forward with its design, engineering and permitting plans to expand lithium-conversion capacity at the Yangtze River International Chemical Industrial Park in the Zhangjiagang Free Trade Zone (Jiangsu province) and the Pengshan Economic Development Park in the Pengshan District (Sichuan province). Albemarle will build a conversion plant at both sites, each of which has planned production capacity initially targeting 50,000 m.t./yr of lithium hydroxide. It is expected that these plants would start construction during 2022 and complete construction by the end of 2024.

Mergers & Acquisitions

Sika to acquire MBCC Group for €5.2 billion

November 11, 2021 — Sika AG (Baar, Switzerland; www.sika.com) has signed a definitive agreement to acquire MBCC Group (Mannheim, Germany; www.mbcc-group.com), the former BASF Construction Chemicals business, from a global private equity firm, for a consideration of €5.2 billion (\$5.96 billion). MBCC Group is active in the field of construction systems and admixture systems and has more than 130 production facilities in over 60 countries.

LINEUP

ADM
ALBEMARLE
ALPLA
BASF
CHEMOURS
DUPONT
EASTMAN
ECOLAB
ELKEM
ENTEGRIS
EVONIK
FLINT HILLS RESOURCES
GEVO
HONEYWELL
INVISTA
LANXESS
MBCC GROUP
NOURYON
SIKA
SYNTHOMER



Look for more latest news on chemengonline.com

Lanxess to separate High Performance Materials business

November 11, 2021 — Lanxess AG (Cologne, Germany; www.lanxess.com) will transfer its High Performance Materials (HPM) business unit to an independent legal corporate structure. With 14 sites worldwide, HPM is a supplier of high-performance plastics that are used primarily in the automotive, electrical and electronics industries.

Flint Hills Resources transfers its propylene business to Invista

November 9, 2021 — Flint Hills Resources, LLC (Wichita, Kan.; www.fhr.com) will transfer its propylene business to Invista (Wichita, Kan.; www.invista.com). The move includes Flint Hills Resources' chemical facilities in Houston and Longview, Tex.

DuPont to acquire Rogers Corp. for \$5.2 billion

November 2, 2021 — DuPont (Wilmington, Del.; www.dupont.com) has entered into a definitive agreement to acquire Rogers Corp. (Chandler, Ariz.; www.rogerscorp.com) for \$5.2

billion. Rogers specializes in engineered materials, including high-frequency circuit materials, ceramic substrates and high-performance foams. The transaction is expected to close in the second quarter of 2022. Rogers operates a global network of 14 manufacturing sites in North America, Europe and Asia. DuPont also plans to divest a significant portion of assets from its Mobility & Materials division.

Ecolab to acquire ion-exchange resin manufacturer Purolite

October 29, 2021 — Ecolab Inc. (St. Paul, Minn.; www.ecolab.com) will acquire Purolite (King of Prussia, Pa.; www.purolite.com), a provider of ion-exchange resins for separation and purification applications in many industrial sectors, including life sciences, microelectronics, nuclear power and food and beverage. The acquisition is valued at approximately \$3.7 billion.

Eastman to sell adhesives resins business to Synthomer

October 28, 2021 — Eastman Chemical Co. (Kingsport, Tenn.; www.eastman.com) entered into a definitive agreement to sell its adhesives resins assets and business to Synthomer Plc (London, U.K.; www.synthomer.com). The \$1-billion sale consists of several product lines, including: hydrocarbon resins, pure monomer resins, polyolefin polymers, rosins and dispersions and oleochemical and fatty-acid resins. The business is currently part of Eastman's Additives & Functional Products segment.

com) entered into a definitive agreement to sell its adhesives resins assets and business to Synthomer Plc (London, U.K.; www.synthomer.com). The \$1-billion sale consists of several product lines, including: hydrocarbon resins, pure monomer resins, polyolefin polymers, rosins and dispersions and oleochemical and fatty-acid resins. The business is currently part of Eastman's Additives & Functional Products segment.

BASF to sell Precision Microchemicals business

October 27, 2021 — Entegris, Inc. (Billerica, Mass.; www.entegris.com) and BASF SE (Ludwigshafen, Germany; www.basf.com) have signed an agreement for the sale of BASF's Precision Microchemicals business to Entegris for \$90 million. The Precision Microchemicals business is part of BASF's Coatings division, operating under the Chemetall brand. It focuses on high-purity materials, including cleaning chemistries and chemical mechanical planarization slurries used in machining and surface conditioning. ■

Mary Page Bailey

MONITOR VISCOSITY SIMPLY

SENSE MIXER MOTOR HORSEPOWER WITH UNIVERSAL POWER CELL

EASY INSTALLATION

- No holes in tanks or pipes
- Away from sensitive processes

VERSATILE

- One size adjusts to motors, from small up to 150hp
- Works on 3 phase, fixed or variable frequency, DC and single phase power

SENSITIVE

- 10 times more sensitive than just sensing amps

CONVENIENT OUTPUTS

- For meters, controllers, computers 4-20 milliamps 0-10 volts

 ALL PRODUCTS MADE IN USA

PROFILING A PROCESS

- Power changes reflect viscosity changes
- Good batches will fit the normal "profile" for that product

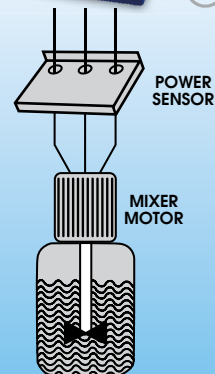
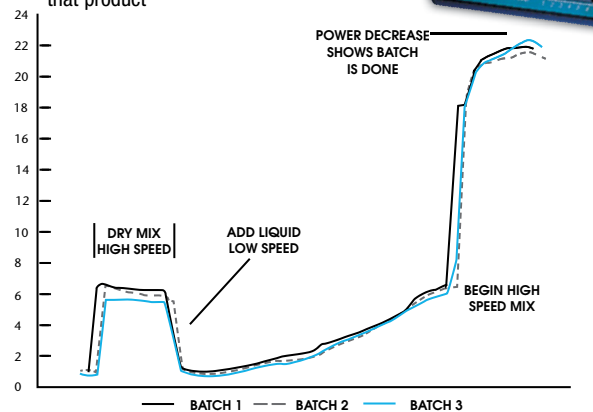

 **LOAD CONTROLS**
INCORPORATED
WWW.LOADCONTROLS.COM

CALL NOW FOR YOUR FREE 30-DAY TRIAL 888-600-3247

For details visit adlinks.chemengonline.com/80076-06

Taking a Holistic Approach to Column Internals

Combining new and improved high-performance column internals and a whole-system view provides a comprehensive solution with more benefits

Today's economic and environmental pressures have chemical processors looking into projects that will help them achieve more throughput from existing columns while also reducing energy use. New high-performance trays and packings can certainly help increase capacity and efficiency of the tower. However, it is a holistic approach to the system and all the internals that yields the greatest benefits.

"Processors are always trying to maximize utilization of their assets, meaning they want to get maximum throughput while maintaining or improving product quality and also being cognizant of their carbon footprint, making energy utilization of the column very important," says Izak Nieuwoudt, chief technology advisor with Koch Engineered Solutions (Wichita, Kan.; www.kochind.com). "It may seem like looking for the Holy Grail, but it is possible to achieve."

For this reason, continues Nieuwoudt, there is a constant drive to improve column internals, leading to some significant improvements in trays and packings, but also to other column internals, as well. "For instance, a high-performance packing might yield even better results if it is paired with improved liquid distributors," he says.

Babak Rafienia, mass-transfer technology manager with Amacs (Houston; www.amacs.com) asserts: "Looking at a tray or packing alone isn't the only way to find better throughput and efficiency. We have seen many applications that need higher throughput and, while replacing conventional trays and packings with high-performance components can help, better results are always achieved when you look at the com-

plete system. Often, we find other considerations, like inlet piping or feed arrangement, can affect the performance of the tower, so it should be looked at as a system to provide a comprehensive solution with a holistic approach."

High-performing trays/packings

If a tower is underperforming due to the use of conventional trays and packings or if a processor wants to improve capacity or efficiency of existing equipment, a move to high-performance trays and packings can indeed enhance performance.

"In the recent economy, we have seen a lot of projects put on hold due to capital, logistical and material issues, and processors are trying to get more capacity and higher efficiencies from existing columns," says Moize Turkey, technology director with Amacs. "In these cases, high-performance internals can boost the performance."

For instance, the most recent generation of Amacs' Superblend ASB high performance random packing (Figure 1) provides superior performance when compared to previous packing generations in terms of both capacity and effi-



FIGURE 1. Amacs' fourth-generation high-performance Superblend ABS packing is a combination of various packing sizes, which provides the efficiency of the smaller and the capacity of the larger packing to provide enhanced benefits

ciency. Likewise, SEMV mini-valve trays are high-performance internals that can improve both capacity and efficiency by breaking vapor jets and providing better vapor-liquid contact, says Rafienia.

Koch's Nieuwoudt adds that the drive to increase column performance has led to improvements in trays and packings that allow increases to both capacity and efficiency in existing columns. For example, the company's new Flexipro valve trays offer improved capacity and efficiency, enhanced push and sweeping of the tray deck, which leads to improved fouling resistance and higher turndown ratio with no increase in pressure drop. This situation opens opportunities for revamps and new vessels. The valve trays extend the operating range of fixed valves to levels close to those of movable valves, while maintaining the performance and reliability of fixed valves.

Mark Pilling, manager of technology with Sulzer Chemtech USA (Tulsa, Okla.; www.sulzer.com), agrees that newer technologies can help achieve both capacity and efficiency improvements. "Our UFM valve trays offer a robust design that works over a variety of operating conditions and consistently provides high efficiency. They were designed using computational fluid dynamics (CFD) to ensure ideal mixing between the vapor and liquid on the tray deck to maximize efficiency while simultaneously increasing capacity," he says (Figure 2).

Taking a holistic approach

Often, the problem with underperforming columns is that existing towers are being pushed too far, which



FIGURE 2. Sulzer's UFM valve trays were designed using computational fluid dynamics to ensure mixing between the vapor and liquid on the tray deck in order to maximize efficiency while simultaneously increasing capacity

may necessitate a revamp of more than just trays and packings, says Andreas Danninger, head of sales engineering with Raschig GmbH (Ludwigshafen, Germany; www.raschig.com). "If the tower was designed and built for certain operating conditions that have since been gradually changed, the tower may not perform well, because the internals are not suitable for the current operating conditions," he says.

"The problems can be manifold," he continues. "From liquid distributors not being able to handle increased liquid loads to the gas distribution setup not being suitable for changed gas-feed flows, to random and structured packings operating close to flooding conditions to mass transfer trays not being able to handle current operating conditions. Addressing these issues not only requires modern high-performance equipment, but also a sophisticated engineering approach."

Danninger says the first option that comes to mind is replacing conventional packing types with a modern, high-performance random packing, such as the Raschig Super-Ring PLUS, which provides increased throughput capacity, efficiency, pressure drop and fouling resistance (Figure 3). "But it is not only the packing that affects column performance. If internals like gas and liquid distributors are not suitable for the actual operating conditions, then the packing can't reach its full potential," he says. "A redesign of the internals, optimized for the actual process conditions, can significantly enhance packing performance."

The same, he says, applies to trays where replacement with a high-capacity tray can enhance

USING COLUMNS FOR CARBON CAPTURE

One of the latest trends is using columns for carbon capture applications. While the technology is not new, the "parasitic" energy demand and the enormous column sizes required for the application necessitate a lot of research and optimization before use becomes widespread, says Koch's Nieuwoudt.

"There has been a lot of activity on the carbon capture front, but there is still a lot of exploratory work to be done before we see a flood of large industrial applications due to the high cost and the required size of the installations," notes Nieuwoudt. "When you look at the size of the units being proposed, they are humongous. Some of the proposed processes would use scaled-up conventional internals and others would be completely different because some proposed carbon capture columns are rectangular vessels of about 60 by 80 ft.

"This presents mechanical challenges around the mass-transfer internals that have to be solved before widespread use," he continues. "The industry is spending time working on proper packings and mechanical solutions for supporting those packings, as well as what the liquid distributor details would look like in a 60-by-80-ft vessel."

Sulzer Chemtech's Pilling adds: "On columns of this scale, issues such as the thermal expansion factors of dissimilar metals can cause problems. Also, there are massive flows coming in, so there are typically multiple feed nozzles at a given column elevation. This requires a lot of time spent with computational fluid dynamics to be sure the vapor flow goes into the column correctly. There are also issues with liquid distributors that must be flow tested, but the distributors are so massive that they are often bigger than the test facility itself."

Despite these and other issues, Sulzer Chemtech has successfully installed carbon capture columns in power plant applications, where during the process of burning fossil fuels, CO₂ emissions emerge. In these applications, after the fossil fuels have been burned, the off-gas stream feeds into the absorption column. In the column, the amine solutions come into contact with the gas stream and absorb CO₂. The larger the contact area, the more CO₂ is removed from the gas. The specialized design of effective structured packings, such as Sulzer's MellapakCC, creates large surface areas of contact for the gas and liquid, enhancing the absorption. The process results in a nearly CO₂-free gas stream and in amine solutions rich in CO₂. MellapakCC packing is again used to treat the amine solution so the CO₂ is removed for storage and the amine liquid is recycled and reused in the process.

While these columns are normally very large and use a lot of energy, these application-specific internals help reduce column size, saving on materials, space and capital and energy costs. □

throughput capacity. For example, the Raschig R-MV provides higher capacity and lower pressure drop per theoretical stage compared to conventional valve trays due to the unique crowned head of the valve, which promotes improved lateral vapor release, reducing froth height and entrainment and increases hydraulic capacity. "However, a careful redesign of the existing trays with optimizations to the downcomer sections of the active panes for the actual operating conditions can further enhance performance and operability of the tower."

Similarly, Christian Geipel, managing director with RVT Process Equipment GmbH (RVT; Steinwiesen, Germany; www.rvtpe.com), says that there is a growing need for tailor-made solutions in revamps of existing plants that need modifications to fulfill new demands or achieve longer, more predictable run times in fouling applications, higher capacities and lower pressure drop, wider operating ranges for more flexibility or better energy efficiencies. These can be achieved by combining high-performance trays or packings with other modern internals.



FIGURE 3. The Raschig Super-Ring PLUS provides increased throughput capacity, efficiency, pressure drop and fouling resistance

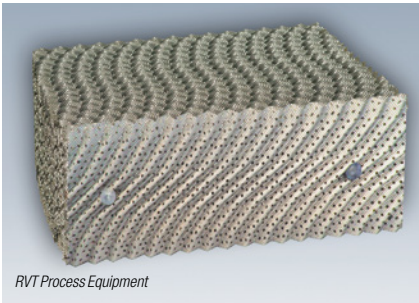

FIGURE 4. RVT has developed a novel high-capacity structured packing, the SP-Line, which offers modified channel geometry to provide low pressure drops and higher capacity

“In terms of energy efficiency, which for mass-transfer equipment mainly corresponds to pressure drop, a revamp from trays or random packings to structured packings is often a solution,” says Geipel. RVT has developed a novel high-capacity structured packing, the SP-Line, which offers modified channel geometry to provide low pressure drops and higher capacity (Figure 4). “However, especially for very low liquid loads, these packings can be combined with other internals such

as modern liquid distributors. An improved spray nozzle distributor that combines spray nozzles with splash plates was developed and has been successfully used in refinery vacuum columns where it reduces entrainment and fouling in the packing sections above the distributor without sacrificing liquid distribution quality to the packing section below.”

Brad Fleming, manager of Sulzer GTC’s proprietary equipment technology group (Houston; www.gtctech.com), says looking at the system holistically can provide benefits outside the column, as well. “High-performance internals can be tailored to achieve many process objectives,” he says. “For instance, in some processes, reducing pressure drop through the column can have benefits on downstream units. If the overhead gas leaving a main fractionator is going to a compression stage, by reducing pressure drop of the fractionator, you can increase the suction pressure to the compres-

or and that reduces the power requirement of the compressors or increases its throughput capacity. You can use the characteristics of the column to yield collateral benefits to other pieces of equipment.”

Fleming continues: “Most processors realize that you can replace standard valve trays and get a 20 to 30% increase in throughput, but if you really understand the process, you can use the benefits to optimize further. This means you can use the same number of trays in a column and achieve better product purity, while at the same time, those improvements in efficiency can be translated into energy reductions because you don’t have to drive the column as hard, so the real benefits come from how you use the improvements in equipment technology to drive a desired, optimized result throughout the process.”

Rainald Pabst, sales product manager for columns and internals with DeDietrich Process Systems GmbH

Call the Experts for all your solids processing

Solids Mixing

- Ribbon & Cone Blenders
- Fluidizing Mixers
- Sigma Blade Mixers
(also for high-viscosity mixing)

Size Reduction

- Wet & Dry Size Reduction
- Steel & Ceramic Lined Mills
- Jars & Jar Rolling Mills

Vacuum Drying

- Dryers & Complete Systems

Applications:

- APIs · Ag-Chemicals
- Biologics · Catalysts
- Ceramics · Chemicals
- Food Ingredients
- Herbicides · Minerals
- Nutraceuticals · Pesticides
- Pharmaceuticals · Pigments
- Polymers · Powdered Metals
- Proteins · Resins · Vitamins

Quality & Innovation Since 1911

PAULO ABBE®

www.pauloabbe.com 855-789-9827 sales@pauloabbe.com

For details visit adlinks.chemengonline.com/80076-07

THE POWER BEHIND PROGRESS



INDECK®

In addition to specializing in manufacturing and design for custom steam power projects, Indeck also carries the world’s largest inventory of stock boilers for immediate and temporary power needs.

Discover why Indeck has been a trusted provider in steam power solutions for over 60 years.

WWW.INDECK.COM | 800.446.3325

For details visit adlinks.chemengonline.com/80076-08



FIGURE 5. DeDietrich's Durapack structured mass-transfer packing offers a higher number of separation stages, better wettability and mechanical stability and glass grids with a larger free cross-area

(Mainz, Germany; www.dedietrich.com), agrees that overall optimization comes from considering the process as a whole. "No two columns are alike. In each individual case it is important to analyze the situation precisely to determine the optimum solution for the separation process and the column."

He points to a revamp of a nitric acid concentration column using modern DeDietrich internals. "The column was originally equipped with cast iron internals, which caused many problems during operation of the plant, including limited load range, permanent blocking of the distributor holes due to breakage of the random packing and risk of fracture due to thermal stress. As a result, the required throughput of the column could not be achieved so the plant produced about 20% less than originally planned and the column required intensive mainte-

nance," he says.

DeDietrich remedied the situation by installing new equipment. In addition to its Durapack structured mass transfer packing (Figure 5), which offers a higher number of separation stages, better wettability and mechanical stability and glass grids with a larger free cross-area, Coretray distribution trays and SiC-channel distributors were installed. "The Coretray distributor trays combine the functions of collection, distribution and support in a single component," he says. "The possible load range is designed individually and is enormous. Thus, lower loads can be handled without loss of distribution quality. Hydraulic overloads up to 280% can be handled without any problem, which is helpful for heavily polluting or foaming media. Further, the SiC-channel distributor is characterized by very good distribution quality.

"These improvements allowed the processor to increase performance up to 120% of the original required capacity," he says.

To enable examining systems as a whole, Koch recently launched a software package, TowerView, that performs real-time calculations of the performance and health of equipment inside distillation or absorption towers. "The software takes advantage of the ability to digitalize separation equipment and provides

real-time feedback on the values that cannot be measured," says Nieuwoudt. "Often processors run a distillation column and measure pressure drop, temperature and composition of streams using probes in the column, but these values can't provide information about issues such as whether certain parts of the trays are close to flooding."

"Our calculation methodology provides users with a real-time view of what things look like inside the column to give a proactive view of where the tower is relative to its limitations," he says.

The software can be used online in real time to provide alerts when there are potential problems, or offline to run what-if scenarios that can be used to enhance performance of the column before making physical changes.

According to the experts, looking at problems or enhancing performance of the column should change from focusing on a single point or component and move toward looking at it as a whole package. Often tweaking and finding small optimizations within the entire system can help operators improve the throughput or performance, which isn't always specific to just one internal. A solution-driven strategy that examines the entire picture should be the focus of optimization projects. ■

Joy LePre



GEMCO®

**The Mixing and
Drying Authority**



- Drying, reactions, solid staging.
- Sparging, purging. Spray coatings.
- Loading and unloading integration with automated controls.
- Complete heating and cooling and solvent recovery skids.
- Largest tumble mixing and drying technology center on the planet.

800.654.3626 • sales@okgemco.com

okgemco.com

For details visit adlinks.chemengonline.com/80076-09

Focus on Motors and Drives

A new coupling increases performance of predecessor

Late last year, this company introduced a new type in its N-Eupex coupling series, while increasing the performance and bore capacity of the entire series. The new double-cardanic N-Eupex DK (photo) connects the shaft ends of the drive and driven machine via two elastomer joints instead of only one joint, as is the case with other coupling types. The introduction of the second elastomer joint increases the damping properties of the coupling and results in a lower torsional stiffness. This reduces vibrations, and the adjacent machine components are less stressed. In addition, the possible radial offset is increased more than fourfold. At the same time, this company increased the performance of the entire N-Eupex series by approximately 30%, and the bore capacity by up to 25%. Users benefit from higher torque, increased rotation speed and a change in size. — *Flender GmbH, Bocholt, Germany*
www.flender.com

These motors now have integrated ProfiNet interface

This company was said to be the first to completely integrate ProfiNet functionality, including the PROFIdrive profile with application classes 1 and 4, into motors as standard. This offers ProfiNet users significant advantages in cabling, commissioning and operation. Only the power supply and bus connection need to be established, and the motor can be integrated into the commissioning environment, for example, the TIA Portal, and programming can begin. During operation, the controller accesses all motor parameters and uses them for process control, error monitoring, predictive maintenance and many other IIoT or cloud features. BG 95 dPro PN (photo) was the first fully integrated ProfiNet motor from this company. — *Dunkermotoren GmbH, Bonndorf/Schwarzwald, Germany*
www.dunkermotoren.de

Users can operate this speed starter intuitively

The safe, simple and efficient operation of three-phase asynchronous motors is an important objective in a large number of applications. The Contactron Speed Starter (photo) is a new device class that bridges the gap between motor starters and frequency converters with easy operation. The operator interface consists of a rotary switch and three buttons with a display, allowing users to make all settings intuitively. This compact and cost-effective solution provides all of the functions necessary for different speeds. These include normal speed, creeping speed, soft start, energy efficiency and ramp functions, and even safe stopping with the Safe Torque Off function. — *Phoenix Contact GmbH & Co. KG, Blomberg, Germany*
www.phoenixcontact.com

These motor brakes are available when you need them

This company has introduced a quick-ship program for MagnaShear motor brakes (photo), with parts ready for assembly in as little as a day. Brakeless brake motors from ¾ to 5 hp are also in stock, so that assembled brake motors can be delivered quickly, eliminating supply chain concerns, and the need to use inferior dry friction-braking systems. MagnaShear motor brake assemblies feature oil shear technology, so they do not require regular maintenance or adjustment. With quiet, smooth operation and high accuracy and repeatability, they provide a long service life (typically 5 to 10 times that of dry friction brakes), says the company. — *Force Control Industries, Fairfield, Ohio*
www.forcecontrol.com

New coating enables boost in efficiency of electric motors

Electric motors have laminated cores that are made up of thin laminations of electrical steel. These laminations are coated on both sides to insulate them, which reduces magnetic losses. The coatings must also be heat resistant. Beckry Core is a waterborne core-plate varnish (CPV) that not only al-



Flender

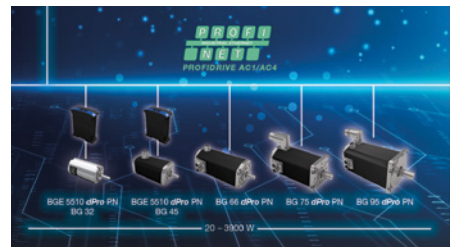

Dunkermotoren



Phoenix Contact

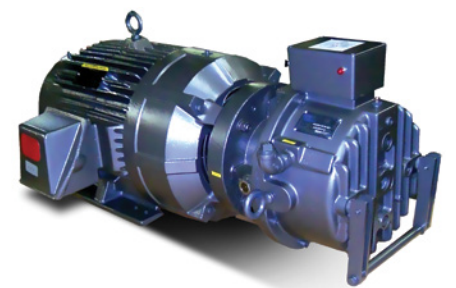

Force Control Industries



Beckers Group

lows thinner coating than other products on the market, but also enhances electrical motor efficiency by reducing power losses in the core laminates (photo) and improving magnetic properties, says the company. — *Beckers Group, Berlin, Germany*
www.beckers-group.com

Certified functional safety products introduced

Launched in April, this company's Certified Safety Products (photo) provide machine builders with a verified and reliable solution to increase the safety of processes and machines. The rail brakes, servomotor brakes and rod locks (photo) are said to be the first in North America to earn the Intertek Functional Safety (FS) Mark. They are certified to comply with ISO 13849-1, Categories B through 4 and Performance Levels PLa through PLe. With spring-engaged, air-released functionality, these products are default to lock, making them ideal for emergency stopping and holding applications. The rail brakes, servomotor brakes and rod locks can be mounted to servo motors, linear devices, pneumatic cylinders, round rails, linear rods, round shafts and linear guide systems. — *Nexen Group, Inc., Vadnais Heights, Minn.*
www.nexengroup.com

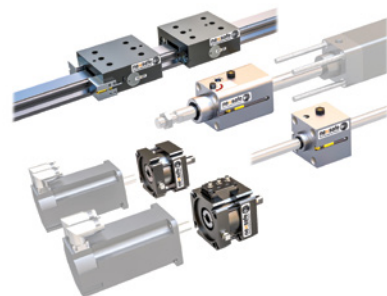

Nexen Group



Siemens

Motors meet or exceed NEMA Premium efficiency standards

The Simotics SD200 severe-duty motor in frame size 440 (photo) is the latest offering in the low-voltage Simotics motor family. Providing high productivity and energy-efficient operation in all torque ranges, these new cast-iron NEMA motors are built to power pumps, fans, compressors, hoists, winders and similar equipment in harsh environments. The SD200 motors offer 75–800-hp output and feature 444-5013 cast-iron frames for operation in 460- and 575-V ranges. They meet or exceed NEMA Premium MG1 Table 12-12 efficiencies. A wide selection of options is offered, including IP56 ingress protection, encoders, brakes and blowers, plus others to suit the application. They are designed for use in the harsh environments of oil-and-gas, petrochemical, grain and rock production, plus food-and-beverage and other sectors with

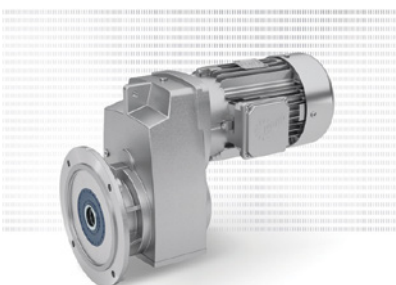

NORD Gear



Rockwell Automation

Div. II, Class 1 and 2 conditions. — *Siemens Corp., Chicago, Ill.*
usa.siemens.com

Shaft gear units provide more power, flexibility and reliability

This company's redesigned line of small Clincher parallel gear units (photo) delivers increased power and torque capacity for a variety of applications. These re-engineered versions are lightweight, have improved heat dissipation, are more cost-effective and are available with this company's nsd tupH sealed-surface conversion for wash-down and extreme environments. When combined with variable frequency drives, Clincher units provide efficiency and economy for a wide range of systems. Two mounting configurations are possible: a B14 face flange/foot mounted version and a B5 flange version. — *NORD Gear Corp., Waunakee, Wis.*
www.nord.com

Improved performance for medium-voltage drives

Earlier this year, this company introduced multiple enhancements to the Allen-Bradley PowerFlex 6000T medium-voltage drives (photo). The drives now include TotalFORCE technology, which provides precise control of speed and torque, diagnostic information for tracking system health and automatic adjustments to keep operations running smoothly. The PowerFlex 6000T drives follow speed or torque commands very closely in both open- and closed-loop vector control modes to deliver the precise control required for high performance and large loads. The drives also continuously monitor operations to track the health of electrical components in the drive and motor, and provide real-time diagnostic information to the control system. With this information, users can better predict maintenance requirements well before component failures and take action to prevent unplanned downtime. Additionally, adaptive control features within the PowerFlex 6000T drives help isolate potentially harmful vibration and resonances, and automatically compensate for variances to help keep applications running. — *Rockwell Automation Inc., Milwaukee, Wis.* ■
www.rockwellautomation.com

Gerald Ondrey

Leveraging Time-Series Data to Empower Process Experts

Using new analytics technologies to address process challenges and improve production makes business sense

Chemical manufacturers are continuously challenged to achieve operational excellence. Many factors are involved with reaching this goal. However, one crucial path forward is being able to fully leverage sensor-generated time-series data by being able to analyze it. Companies realize this, but without the proper tooling, they struggle to achieve this objective.

Huntsman Corp. (The Woodlands, Tex.; www.huntsman.com), a global manufacturer and marketer of differentiated and specialty chemicals, was able to overcome this challenge by empowering their process experts with self-service analytics. This tooling enabled them to answer three of the top production questions every organization like theirs is faced with:

- What is happening in the process?
- Has this happened before?
- Why is this happening?

Self-service analytics

With the self-service analytics platform supported by TrendMiner (Houston; www.trendminer.com), Huntsman process engineers and operators are able to search through historical data to look for good and bad production behavior, allowing them to carry out the analytics themselves. They can create “fingerprints” of ideal operating zones, and set monitors against these fingerprints. If a deviation occurs, alerts are sent out via messages, emails or dashboards to notify personnel about the issue, giving them time to take corrective action. A 24-hour engineering support system is therefore set in place, covering times when engineers are not on site (Figure 1). Additionally, self-service analytics can enable process experts to set monitors to predict performance and send out early warnings, and can even be used in conjunction with Lean Six Sigma continuous improve-

ment projects.

Huntsman has also been able to eliminate data silos. Like many manufacturing companies, their operational data was traditionally kept in separate silos, each within its specific teams and process/business applications.

With self-service analytics, users can contextualize, centralize, save and share their operational data with all teams. By eliminating these silos, it became possible to move toward combined organizational production overviews for all sites, both locally and globally. With this shared information, they saw global collaboration and team efficiency improve, which resulted in enhanced and more insightful resolution of production problems.

Fingerprinting batch processes

Traditionally, Huntsman’s teams would check batch profiles using Microsoft Excel — an approach that required a substantial amount of production expertise and time. However, after implementing a self-service analytics platform in 2018, they were able to become much more efficient by creating fingerprints of good operating zones to check batch quality against specifications.

In one of its polyols processes, distinct pressure and temperature profiles are required to consistently produce high-quality material. Huntsman’s teams used fingerprints as realtime monitors to continuously check the process for deviations. Process experts were able to quickly identify subtle disturbances that would be difficult to capture in a numerical model. As the monitors



FIGURE 1. Self-service analytics monitoring capabilities provide 24-hour engineering support

gave early warnings for unexpected heat input, there was no need to check afterward if there were any abnormalities, allowing operators to take appropriate action in time (Figure 2). This new approach to batch analysis and monitoring led to a significant reduction in off-specification batches and a significant increase in product quality.

Improving quality assurance

In one of Huntsman’s Advanced Materials plants, numerous batches in a wiped-film evaporator exceeded the solvent specification limit, resulting in off-specification products. The process experts also observed a multi-year drift in quality as measured by the quality assurance laboratory. They suspected this problem resulted from a change in testing methods, but this hypothesis and the frequency of off-specification production needed to be investigated.

A six-sigma analysis following the “define, measure, analyze, improve and control” (DMAIC) strategy was performed using the various capabilities of self-service analytics, such as value-based searches, layer comparisons, statistical comparison tables, scatterplots, filtering and the recommendation engine.

The team used scatter plots to easily track batch performances for insight about which batches were

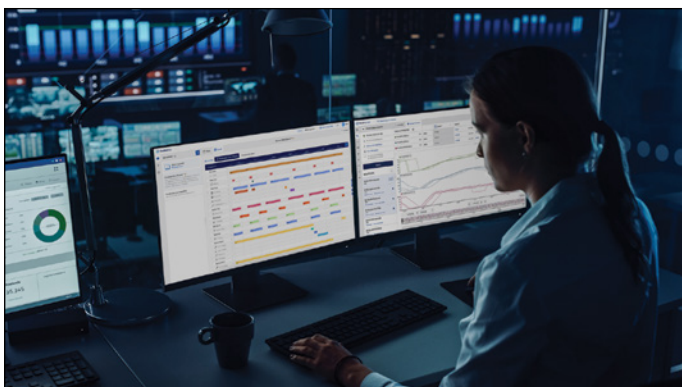

Figure 2. Setting process monitors can give process experts early warnings when batch quality is off-specification

outside of the acceptable operating zone. Multiple differences between the plant's on-specification and off-specification production campaigns were found, which convinced them that long-term changes had been occurring in the process. Further investigation allowed the process experts to rule out the misreading of flowmeters, and they found a non-negligible offset between measured and true pressure.

With self-service analytics, the process experts completed a faster

ings, quality improvements were realized within days after making process changes.

Using new technology like self-service analytics can effectively address process challenges and vastly improve production. Huntsman understands this. Now, its teams of process experts have a continuous, constant view of production, resulting in more profitable and efficient production management in a highly competitive market. ■

Edited by Mary Page Bailey

root-cause analysis on a much larger data set. They were also able to identify differences in the subtle pressure readings and thus call for more tests to be conducted. Based on these find-

Authors



Jasper Rutten (Email: jasper_m_rutten@huntsman.com) works at Huntsman Corp. as the manager of the company's Advanced Analytics team, which sets out the global route on digitalization and advanced analytics for upstream methylene diphenyl diisocyanate (MDI) manufacturing facilities. He joined Huntsman in 2000 after graduating as a chemical engineer from Twente University in the Netherlands. His extensive experience in chemical engineering provides a solid basis to lead the global journey of sustainably bringing industry 4.0 into practice.



Edwin van Dijk (Email: edwin.vandijk@softwareag.com) is the vice president of marketing at TrendMiner NV (www.trendminer.com). He has over 20 years of experience in the process and power industries. He spent more than 10 years at Greenock, selling plant design software to owner-operators and contractors, followed by a role as business development manager at BlueCielo ECM Solutions. In his last role as director of global marketing at BlueCielo, he focused on brand recognition, product positioning and go-to-market launch plans. Within TrendMiner, van Dijk is responsible for the global marketing strategy, which includes a focus on educating the market on the benefits of data analytics in the process industry and the opportunities available with TrendMiner's solutions.



Ultrapen PTBT Series
Smartphone/Tablet Compatible Testers

X2
MYRON L COMPANY

Compatible with Android and iOS Devices.

Download on the App Store | GET IT ON Google Play

Bluetooth Enabled



900 Series
Multi-Parameter Monitor/Controller

Conductivity, Resistivity, TDS, pH, ORP, Salinity, ISE, Flow, Pressure, with Touchscreen LCD +more!





www.myronl.com
760-438-2021



DESIGNED, ENGINEERED AND ASSEMBLED IN THE USA



For details visit adlinks.chemengonline.com/80076-10

New Products

Digitize weighing processes with this balance and software

The combination of XPR series balances and LabX Software (photo) enables users to digitalize laboratory weighing processes and ensure accurate results, full traceability and data integrity. LabX Balance software integrates fully with laboratory-information systems, such as chromatography software, and enables a seamless flow of data throughout the entire analysis workflow. LabX sends weighing results directly to where the weight values are required for subsequent analyses and ensures traceability back to the starting point. Now available in Version 12, LabX software guides users through SOP workflows on all connected XPR Balances, including the new XPR automatic balance, to ensure every operator follows the same procedures. — *Mettler-Toledo GmbH, Greifensee, Switzerland*
www.mt.com

A new rupture disc is ASME BPE compliant

The new IntegrX-HPX rupture disc (photo) addresses the need to improve process performance, reliability and safety within the biopharmaceutical industry. The IntegrX-HPX combines the unrivaled performance of the company's HPX with ASME BPE (bioprocessing equipment) compliant crevice-free design, removing the need for integral seals. Manufactured and tested to optimize service life and performance, the IntegrX-HPX is a semi-circular, scored, reverse-acting rupture disc is suited for cyclic process conditions from full vacuum to 95% of the stamped rating. With the disc built into a cartridge, the robust welded design of the IntegrX-HPX mitigates the impact of downstream piping loads on the disc burst pressure and overall performance. — *Continental Disc Corp., Liberty, Mo.*
www.contdisc.com

Bringing artificial intelligence to asset-performance management

The launch of Ability Genix Asset Performance Management (APM) Suite (photo) brings next-generation artificial-intelligence (AI)-based predictive maintenance, asset reliability

and integrity insights to the chemical process and utilities industries. Genix APM is an enterprise-grade application to monitor assets, prescribe maintenance actions, improve equipment utilization and support lifecycle analysis and capital planning. By assessing the remaining useful life of industrial assets, Genix APM generates a plan for preventive maintenance, which can extend equipment uptime by as much as 50% and increase asset life by up to 40%, says the company. The Genix APM Suite makes it easy to add condition monitoring to existing operational technology (OT) landscapes, enables prioritization of maintenance activities based on AI-informed predictions and provides a comprehensive overview of asset performance. — *ABB Ltd., Zurich, Switzerland*
www.abb.com

Raising the bar for heat pumps up to 95°C

The RedGenium heat pump, combined with the new Grasso V XHP reciprocating compressor (photo), enables the provision of temperatures of 95°C with high efficiency. In addition to the temperature advantage, the largest V XHP compressor also offers almost double the capacity compared to previous models. The new system is well-suited for many processes with high heat-load requirements. Electrically driven heat pumps can replace conventional fossil-fuel-based heating systems. They use either available process waste heat or other heat sources from the environment and transfer the heat to a high temperature level. — *GEA Group AG, Düsseldorf, Germany*
www.gea.com

Web-based platform streamlines molecule discovery chemistry

Last month, this company released Torx Test and Torx Analyze (photo) to complete the Torx platform — a single web-based solution that enables drug discovery teams to work together, share knowledge, manage resources and track progress throughout the design-make-test-analyze (DMTA) workflow. Torx Test connects chemists and assay scientists to enable seamless scheduling, management and results delivery for biological, physico-



Mettler-Toledo



Continental Disc



ABB



GEA Group



Torx Software

ACHEMA2022

GET READY FOR THE UNEXPECTED

Add to



calendar!



INSPIRING SUSTAINABLE CONNECTIONS

World Forum and Leading Show for the Process Industries

ACHEMA is the global hotspot for industry experts, decisionmakers and solution providers. Experience unseen technology, collaborate cross-industry and connect yourself worldwide to make an impact.

Are you ready?

#back2live:

4 – 8 April 2022

Frankfurt, Germany

www.achema.de

chemical and other assays. It removes the administrative burden from the testing process by providing a platform to submit requests upon compound registration, as well as followup requests from Torx Make and monitor progress in realtime. Torx Analyze combines 2D and 3D analysis of molecule data loaded from corporate databases with the extensive information sharing and molecule design capabilities of Torx Design. — *Torx Software Ltd., Cambridge, U.K.*

www.torx-software.com

New touchscreen coulometer for gas-stream analysis

The CM5016 C/S coulometer (photo) provides highly accurate, absolute determination of carbon or sulfur content in any gas stream containing CO₂, SO₂ or H₂S. The coulometer is used as the detector with a sample-acidification front-end unit, detecting carbon or sulfur (or both) in the range of 0.01µg to 100 mg. The CM5016 coulometer is equipped with a new 12-in. touchscreen display assembly for enhanced user interface. — *UIC, Inc., Joliet, Ill.*



www.uicinc.com

Manage the automation lifecycle of water and wastewater units

The newest release of the EcoStruxure Automation Expert system, Version 21.2 (photo), provides complete life-cycle management, seamless integration of IT/OT services and improved system diagnostics for automation systems in water and wastewater treatment plants. EcoStruxure Automation Expert allows for automation software to be separated from the hardware, providing more versatility for enterprises to break their dependency on proprietary hardware suppliers. EcoStruxure Automation Expert aims to provide a single platform that evolves with time for water and wastewater subsegments, including: treatment infrastructures (including desalination plants and industrial wastewater), network infrastructures and other water resources, such as irrigation systems. EcoStruxure Automation Expert offers seamless connection to many engineering software platforms, so new designs or changes can be validated virtually. — *Schneider Electric USA, Andover, Mass.*



Schneider Electric USA

— *Schneider Electric USA, Andover, Mass.*

www.se.com/us

Fast, safe integration of Ex i isolators

The pac-Carrier 9295 (photo, p. 23) is a new, space-saving integration solution for this company's 12-mm ISpac Ex i isolators. This significantly simplifies the installation and wiring of isolators to input/output (I/O) cards in automation systems from all manufacturers. Prefabricated connecting cables reduce the risk of wiring errors. Further-

more, the installation time is reduced by up to 40% thanks to the isolators' tool-free mounting, says the company. This integration solution is particularly suited for projects involving a high number of channels. The new pac-Carriers are available in 8- and 16-slot versions, thereby enabling up to 32 signals to be connected. The variant with eight slots is only 110 mm wide. An additional HART multiplexer coupling only requires 36 mm of extra space. ISpac devices and the pac-Carriers are approved for use in Zone 2 decentralized installations. The pac-Carrier can also be used for functional safety applications up to safety integrity level (SIL 3). — *R. Stahl AG, Waldenburg, Germany*
www.r-stahl.com

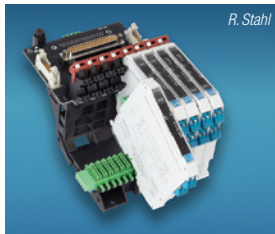

New clarifier has a large settling area within a small footprint

The Leopold Texler lamella clarifier (photo) for water treatment uses a series of inclined lamellas designed to fit into rectangular clarification basins, providing a large settling area within a small footprint. With its efficient removal of solids, the clarifier attains very low turbidity levels and improves the filterability of water. The lamella sheets are installed at a 55-deg angle, increasing the treatment capacity by up to 100% compared to conventional sedimentation systems, says the manufacturer. Solids settle without blocking the pathway of the water. The unique trough covers have an integrated weir design to ensure even flow distribution throughout the length of the clarifier. Texler's lamellas are made from a hydrophobic geotextile high-density polyethylene (HDPE) that has water-repellent and flexible properties to prevent sludge accumulation on the lamella sheets, reducing the need for regular cleaning. — *Xylem Inc., Rye Brook, N.Y.*

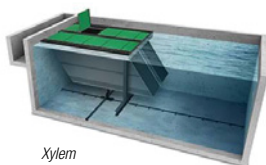

www.xylem.com

Enhance EHS compliance and education with this new learning system

This company launched a new learning management system (LMS) with expanded capabilities for increased flexibility, functionality and scalability. The new LMS will also integrate the SAP Litmos tool as part of its offering. With an easy-to-navigate user interface, and simplified administration and content management, the new LMS offers a wealth of learning content related to environmental, health and safety (EHS) compliance. The new system also includes robust and flexible reporting, as well as social learning and gamification features with badging and leaderboards. — *DuPont Sustainable Solutions (DSS), Wilmington, Del.*

www.dsslearning.com

Mary Page Bailey and Gerald Ondrey



Controlling emissions, improving efficiency

Tailored integral process solutions for industrial gas cleaning

For decades, GEA has been a global leader in the development, design and installation of emission reduction systems and technologies for customers in the process industries such as:

- Dust removal
- Flue gas cleaning
- Absorption of gaseous pollutants
- NOx reduction
- Gas cooling

Thanks to its unparalleled innovation and expertise, GEA delivers made-to-measure emission control systems that keep customers competitive and compliant beyond legal emission requirements.

All with the lowest energy consumption.

Get in touch today at gea.com/contact



Cake Filtration Basics

Department Editor: Scott Jenkins

Filtration is arguably the most common unit operation in the chemical process industries (CPI). Filtration processes can be divided into three broad categories: cake filtration, where the incoming slurry contains enough solid material to form a cake on the filter medium; clarifying filtration, which involves feeds with solids levels that are too low to form a cake and where the solids become embedded in the filtration medium; and crossflow filtration, where the feed flows parallel to the filtration surface, rather than the conventional perpendicular flow. This one-page reference summarizes the basic operation and mechanism for cake filtration processes.

Cake formation

In cake filtration, feed is introduced upstream of the filter, and a layer of solids is deposited onto the surface of the filter medium. Some of the particles in this layer of material bridge the gaps between the fibers of the filter medium, a process known as bridging. Subsequently, new particles are deposited onto this existing layer, forming a second layer of solids. The concept is depicted in Figure 1a, where the dark circles represent the solid portion (for example, fibers) of the filtration medium, and the gaps between the circles denote the flow path for filtrate. The process continues, with new solids forming additional layers adjacent to solids already deposited, and in this manner, a cake forms. Rather than the actual medium, the cake itself acts as the filtration medium, determining the quality and flowrate of the filtrate. The role of the actual medium is only to support the cake.

Cake filtration is suitable only for feeds containing enough solids to form a cake — at least 1 vol.%. Higher levels of feed solids lead to better results, including improved bridging and more porous cakes.

Media types

There are a variety of media available, including paper, textiles, polymers,

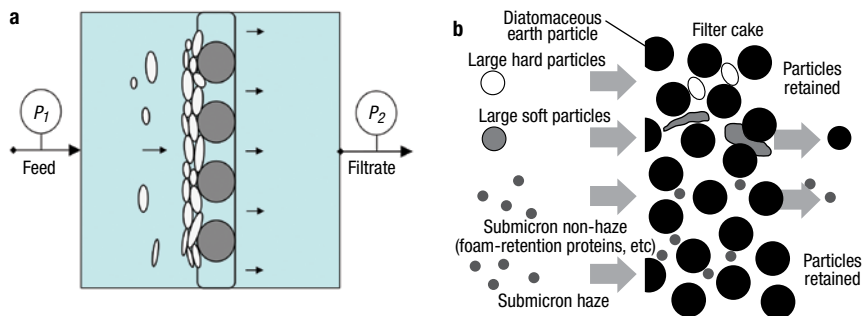

FIGURE 1. In cake filtration (a), the separation takes place on a buildup of particles (cake) on the filter medium. In some cases (b), more than simple size exclusion may be involved

and even wire screens. Among the materials used are polyolefins, nylon, polyester, acrylics and fluorocarbons. Both woven and nonwoven media are employed, over a wide range of porosity. When selecting a medium, consider mechanical strength, chemical compatibility with the process material, temperature tolerance, ease of cleaning and porosity. If the medium is too coarse, solids may become lodged in the openings, leading to blinding. In other cases, solids may not be retained and bridging may not occur. Conversely, a medium that is too tight will impose an unnecessary restriction to liquid flow, leading to reduced productivity.

Filtering soft solids

Solids that are soft, slimy or gelatinous tend to pack tightly, forming cakes of low permeability. This problem can be alleviated by the addition of a small amount of filter aid to the feed slurry. Filter aids are inert, highly porous materials that act to separate blinding solids, leading to a more open cake and in turn a higher filtration rate. Filter aid added directly to the slurry is known as body feed. Alternatively, prior to introducing the feed slurry, a layer of filter aid can be deposited onto the filtration medium to form what is known as a precoat.

Filter aid

Several types of filter aid are available. Most common is diatomite (diatomaceous earth), the skeletal remains of single-cell algae, composed primarily of silica. Diatomite offers the highest clarity of all types of filter aid. Another

option is perlite, which is milled volcanic glass composed mainly of potassium aluminum silicate. Because perlite is not as tortuous as diatomite, the high clarity levels achievable with the latter are not possible. Nevertheless, perlite may be more cost effective than diatomite for separation of coarse particles. This is because the density of perlite is lower, so that less material is needed to form a precoat of a given thickness. Other types of filter aid include expanded cellulose.

Cake filtration mechanism

A filter precoat with diatomaceous earth (DE) is represented in Figure 1b. This diagram shows how filtration by simple size exclusion may be an oversimplification. At the top of the figure, rigid particles larger than the openings in the DE precoat are retained, while smaller ones pass through, consistent with expectations. However, the compressible nature of the large, soft particles shown in Figure 1b allows them to squeeze through, even though the particles are smaller than the openings.

The sub-micron, non-haze particles shown in the figure also are not retained, but this is expected because these particles are smaller than the pores in the cake. On the other hand, the sub-micron haze particles seen at the bottom of the diagram are retained even though they are larger than the openings. This is attributable to some mechanism other than physical exclusion, perhaps electrostatic or hydrophobic interaction. ■

Editor's note: This column is an excerpt of the following article: Gabelman, A., An Overview of Filtration, *Chem. Eng.*, November 2015, pp. 50–58.

Production of Citric Acid

By Intratec Solutions

Citric acid is a naturally occurring tricarboxylic acid commonly found in plants and animals (Figure 1). In its pure form, it is a colorless compound readily soluble in water. Citric acid is mainly used to add taste to food and soft drinks, and as acidulant for dietary supplements and pharmaceuticals. It is also used as the following: an anticoagulant; mineral flotation agent; industrial cleaning/electroplating/anodizing reagent; animal food additive (digestion aid); and water treatment agent. Citric acid can be used in the manufacture of other products, including: dibasic ammonium citrate; ammonium ferric citrate; calcium citrate; citrazinic acid; citrated fatty acid glycerides; lithium citrate; potassium citrate; sodium citrate; tri-*n*-butyl citrate; and triethyl citrate

Citric acid can be obtained from natural sources (for example, lemons, limes and oranges) and can be synthetically produced either via chemical reaction or microbial fermentation. Large-volume industrial production of citric acid, however, is based almost exclusively on microbial fermentation of a carbohydrate substrate, in which a strain of *Aspergillus niger* is employed to convert sugar to citric acid. Raw materials commonly used are molasses, sugar (raw beet, refined beet), cane sugars, syrups (prepared from wheat, corn, potato or other starch).

Production process

Citric acid production from corn starch comprises three major sections: (1) corn starch saccharification;

(2) fermentation; and (3) products treatment (Figure 2).

Corn starch saccharification. Corn is fed to hammer mills to be crushed into a coarse grind meal containing all kernel components. This meal is routed to a liquefaction vessel, along with hot process condensate and alpha-amylase enzymes. The corn starch is enzymatically hydrolyzed, producing maltose and higher oligomers. The slurry from this step is sent to a saccharification tank, where it is mixed with gluco-amylase enzymes, which cleave the maltose and higher oligomers into glucose.

Fermentation. Glucose is mixed with process water, nutrients and ammonium nitrate, and fed to the fermenters. Fermentation is performed in fed-batch mode and under aerobic process conditions in agitated, jacketed fermentors. After glucose exhaustion, the batch phase is finished, and the fed-batch phase is started. During the fed-batch phase, glucose and nutrients are continuously supplied.

Products treatment. After the fermentation step, the fermentation broth is sent to a rotary vacuum filter, separating non-fermented biomass (which is sent to a wash step) from a liquid stream containing citric acid that is routed to the evaporation stage. The biomass is centrifuged and washed for citric acid recovery, which is sent to evaporation, while the biomass cake is dried in a rotary dryer, generating dried distiller's grains with solubles (DDGS) byproduct. In the evaporation step, the broth is concentrated, and then sent to chromatographic separation equipment to

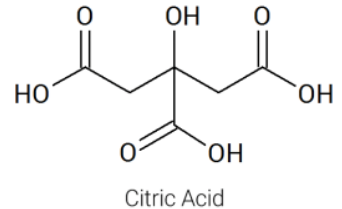

FIGURE 1. Citric acid is used in a variety of applications, including for taste in foods and beverages

remove biomass residues, while the vapor is condensed and recycled to the liquefaction area. The citric acid solution is then fed to ion-exchange column for separation of magnesium and potassium ions, and to a crystallizer, forming citric acid crystals, which are routed to a vacuum filter to be separated from the mother liquor. Most of this liquor is returned to crystallization upstream, but a fraction of it is purged to avoid impurities build-up. The solid citric acid cake is directed to a rotary dryer to remove residual water, then sent to blending silos and packaging, from which bulk and bagged citric acid are obtained, respectively.

Product grades

The uses and applications of citric acid vary according to the product grade. The main forms of citric acid are: U.S. Pharmacopeia (USP) grade; reagent grade; and monohydrate grade. This organic acid may be produced in crystalline form, anhydrous, with several granulations; or in solutions with different concentrations (for example, 50% w/w), with grades varying in appearance, purity and color. ■

Editor's note: The content for this column is developed by Intratec Solutions LLC (Houston; www.intratec.us) and edited by *Chemical Engineering*. The analyses and models presented are based on publicly available and non-confidential information. The content represents the opinions of Intratec only.

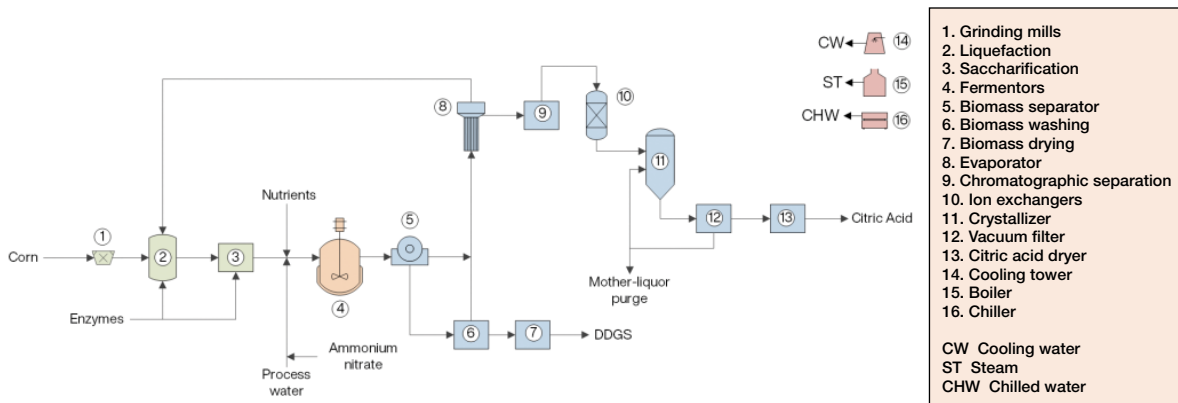

FIGURE 2. The diagram shows a process for making citric acid by fermenting corn sugars

Unlocking Hydraulic Limits in a Revamp

Follow the practical tips discussed here to accelerate hydraulic revamp projects and increase the success rate

Nattapong Pongboot
Global R&D

IN BRIEF

REAL-LIFE DILEMMAS

THEORY VERSUS REALITY

TEST-RUN BEST PRACTICES

EXECUTION PLAN

EXAMPLE 1:
HYDROCRACKER FEED PREHEATER

EXAMPLE 2: INCREASED WASH WATER FLOW

EXAMPLE 3: INCREASED DIESEL PRODUCTION

EXAMPLE 4: IMPROVED DIESEL RECOVERY

ADDITIONAL TIPS

Conducting a thorough hydraulic check is a crucial part of a successful plant revamp. Depending on the remaining margin of the hydraulic system, a certain degree of modifications may be required to accommodate a new unit throughput or configurations.

Conventional hydraulic calculations can be time-consuming, involving engineering documents, possibly with expensive hydraulic calculation software. This article provides helpful tips to significantly reduce the person-hours required for hydraulic review. Also, unorthodox, yet practical, methods for equipment sizing will be demonstrated as fast-track solutions to unlock hydraulic constraints at a chemical process industries (CPI) facility. These tips and methods come out of the author's experience as a plant operator and designer, and are illustrated with several real-world examples.

Real-life dilemmas

As a former petroleum-refinery process engineer, the author had opportunities to work with multiple reputed design companies on different revamp projects. Surprisingly often, these companies applied hydraulic design criteria intended for new units to revamp projects without a thorough understanding of why these criteria were there in the first place. As shown in Table 1, many of these criteria, such as pressure drop per 100 m, are primarily based on economics (capital expenditures versus operating expenses) and only intended to provide an economical solution to new unit designs. This approach does not apply in the case

of revamp projects, where a design engineer should seek to exploit every bit of design margin to avoid costly equipment modifications. It must be noted that piping changes are generally expensive and undesirable in most revamp projects.

I would like to stress that conflicting with these hydraulic design guidelines does not mean your existing equipment cannot be used in revamp scenarios unless they are integrity or reliability criteria (for example, erosion limit). More importantly, the economic justification is different here, as the investment in the existing equipment has already been made. Utilizing existing hardware is always a better choice from a financial and practical perspective, thus requiring a careful hydraulic assessment.

Another essential concept that was often missing is practicality. Many engineers from these design firms solely relied on theoretical hydraulic calculations and ignored the real-world data, such as pressure survey data. While the author always offered test-run data (or the opportunity to do test run), many failed to use them properly. To make matters worse, some of these engineers confidently said that there was no such need for plant data, as they thought they could figure out everything based on their computer software. The author has experienced multiple disastrous revamp projects that failed to meet the revamp objectives just because



FIGURE 1. The photo on the left shows the inner pipe wall of a severely fouled fuel oil line. The photo on the right shows a tube bundle heavily fouled by asphalt and coke. Both examples are non-idealities illustrating why ideal hydraulic models deviate from reality

TABLE 1. EXAMPLES OF LINE DESIGN CRITERIA TYPICALLY USED BY ENGINEERING COMPANIES

Item	Detail	Recommended high limits	
		$\Delta P/100$ m, bar/100 m	Velocity, m/s
1	Pump suction lines (bubble point fluid)	0.11	1.8
2	Pump discharge lines (carbon steel)	0.91	6.1*
3	Amine piping (stainless steel)	0.34	3*
4	Reboiler inlet line	0.07	1.5

*Integrity criteria

Many of these values are based on economic criteria, while some are intended to ensure piping integrity

the designer did not incorporate actual plant data and equipment performances during the design phase.

Moreover, people tend to overly focus on rotating equipment. Throughout my experience with revamps, the suggestion has been made by former colleagues that solving hydraulic issues could be accomplished by replacing pumps and compressors. This notion is not always the case, and could lead to a costly solution, like replacing a large compressor. Ask yourself if you would still replace a pump or compressor if you found that the inlet block valve was accidentally closed. More often than people think, pump and compressor issues do not result from the equipment itself.

These situations might sound unreal to some readers, but they are based on true stories. Some people do not view through a different lens when dealing with revamps, regardless of how experienced they are.

Theory versus reality

Theoretical hydraulic calculations are undoubtedly good estimations, but it is important to remember that engineering assumptions or even hydraulic models themselves (such as Darcy-Weisbach or Hazen-Williams models) may not perfectly represent the real world. For example, the hydraulic design assumptions listed in Table 2 might be reasonable for a new design. However, it does not mean that the hydraulic model developed using the same assumptions will reflect exactly what happens in the existing hydraulic system.

This difference between theory and reality is the primary reason why a design margin is always applied when designing a new piece of equipment or device. The margin accounts for any non-idealities and provides additional operational flexibility. Almost all process piping, pumps and compressors are designed based on rated flowrates — typically 110–120% of normal. Therefore, 10–20% spare capacity may be available for the revamp operation.

Some examples of non-idealities in hydraulic systems include fouling, corrosion, erosion and so on. A piping system or asset might be fouled (or corroded), thus affecting both actual pipe roughness and flow area to a certain degree (Figure 1).

More interestingly, some revamp projects are effectively a remedy for a previous grassroots design that failed, so repeating the same mistakes by only relying on theories

NOMENCLATURE

$\Delta P/100$ m	Pressure drop per 100 meters
D	Nominal pipe diameter
NPSHa	Available net positive suction head
C_v	Flow coefficient
%Travel	Valve travel
Q_{revamp}	Actual volumetric flow rate for the revamp case
S.G.	Specific gravity at the corresponding operating temperature
%Travel _{base}	Valve travel for the base case
$C_{v,base}$	Flow coefficient for the base case
ΔP_{base}	Pressure drop across the control valve for the base case
ΔP_{revamp}	Pressure drop across the control valve for the revamp case
$\Delta P_{new\ equipment}$	Pressure drop across the new equipment
$C_{v,revamp}$	Flow coefficient for the revamp case
%Travel _{revamp}	Valve travel for the revamp case
Q_{total}	Total actual volumetric flowrate across the main control and bypass valve
Q_{main}	Actual volumetric flow rate across the main control valve
Q_{bypass}	Actual volumetric flow rate across the bypass valve
$C_{v,total}$	Total flow coefficient across the main control and bypass valve
$C_{v,main}$	Flow coefficient for the main control valve
$C_{v,bypass}$	Flow coefficient for the bypass valve
ΔP_{total}	Total pressure drop across the main control and bypass valve
ΔP_{main}	Pressure drop across the main control valve
ΔP_{bypass}	Pressure drop across the bypass valve
$C_{v,total,revamp}$	Total flow coefficient for the revamp case
ΔH_{base}	Pump's head for the base case
ΔH_{margin}	Design margin for the pump's head
ΔH_{revamp}	Pump's head for the revamp case
$\Delta H_{polytropic}$	Compressor's polytropic head
$\Delta H_{polytropic,base}$	Compressor's polytropic head for the base case
$\Delta H_{polytropic,revamp}$	Compressor's polytropic head for the revamp case
Q_{inlet}	Actual inlet volumetric flowrate
$Q_{inlet,base}$	Actual inlet volumetric flowrate for the base case
$Q_{inlet,revamp}$	Actual inlet volumetric flow rate for the revamp case

does not make sense. This situation further emphasizes the need to augment theoretical calculations with real-world data when one handles a revamp work.

Test-run best practices

One of the objectives of a unit test run is to determine the actual performance capabilities and constraints of

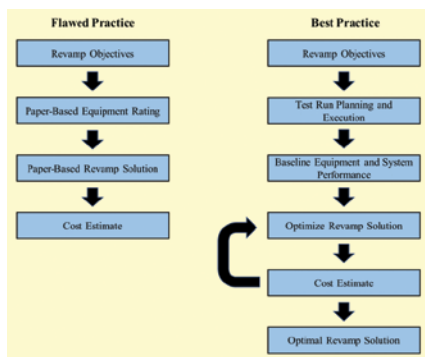

FIGURE 2. To improve success and minimize capital cost, the author recommends the workflow illustrated on the right and avoiding that on the left

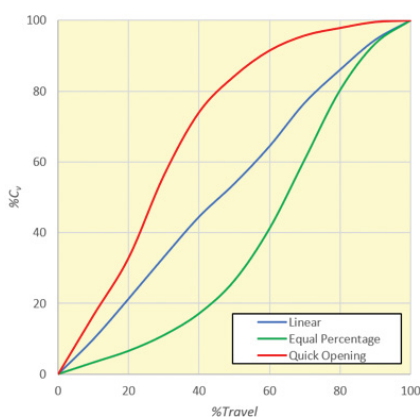

FIGURE 3. The relationship between C_v and valve travel remains virtually the same for any hydraulic system, so it indicates hydraulic availability

an existing system. Process calculations and solution findings based only on theoretical equipment performance may be misleading. A test run is a perfect opportunity to unveil all underlying design margins, which might not be explicitly shown in the equipment datasheet.

A good example is a typical pump-sizing workflow. Several parties, including the licensor, the EPC (engineering, procurement and construction) contractor and pump manufacturer, often add design factors (usually arbitrary and based on institutional knowledge) to each design stage

When assuming a typical design margin of 10%, the compounded design margin that results from each party's addition could be as large as 33% (1.10 to the power of 3) by the time the pump is at the installation site. It is not uncommon to see a pumping system with a highly throttled flow control valve. In some cases, one might need to replace or trim the impeller to improve pumping operation and save energy.

TABLE 2. EXAMPLES OF EQUIVALENT LENGTHS FOR PIPING COMPONENTS		
Piping component	Detail	Equivalent length
Gate valve	Full bore	8–13 D
Check valve	Swing type	92–135 D
Butterfly valve	8 in. and larger	20–40 D
Elbow	90 deg, $R = 1.5 D$	13–20 D
Tee	Flow-through branch	60–72 D

These numbers vary by organization and are primarily intended for the design mode

Moreover, it is also highly beneficial to use the test run data to establish a base case for your revamp and improve the calculation accuracy.

Ignoring the actual equipment and system performances can lead to a situation in which the maximum capacity of the existing equipment is substantially underrated or overrated. Test-run data and observations should be reviewed and discussed with the concerned parties to avoid recommending a change that conflicts with the operational data. For example, the control valve was too small considering the past operational data, but it is not replaced during the revamp execution. In the worst-case scenario, the revamp could fail, as the designer may not address the real issues.

Test runs should be conducted comprehensively at high unit throughputs to ensure that the pressure drop between the measurement locations is more significant than the error of the pressure instruments. As a best practice, preliminarily check your remaining margins before the actual test run. Simulating expected process conditions as a test-run guideline would be helpful.

There is no harm in exceeding the design unit capacity. The real con-

straints are those observed in the field, such as valve travel or motor load, rather than design values on paper. As mentioned earlier, we are trying to utilize all hidden margins and define a new baseline here. If your existing hardware limits the maximum throughput, some actions can be taken during the test run, for example, opening a bypass valve or starting a spare pump. Altering process conditions, such as raising the pressure or level of the suction vessel to increase pump discharge pressure and available net positive suction head (NPSHA), would also help. The author recommends incorporating past equipment inspection and reliability records into the analysis.

This new performance baseline can be developed by measuring flows, temperatures and pressures with well-calibrated instrumentation and analyzing the process streams. Field measurements and checks are highly recommended when deemed applicable, such as a single-gage pressure survey.

In addition to the aforementioned standard process variables, other test-run observations should also be documented, such as: control-valve travel and response; motor load/speed or turbine load/speed; signs of cavitation at pumps and control valves; vibration and noises; and others.

Before using test-run data further, always verify, correct and reconcile it to improve data quality.

Execution plan

As mentioned previously, relying on theoretical calculations can lead to a costly revamp or even a total failure.

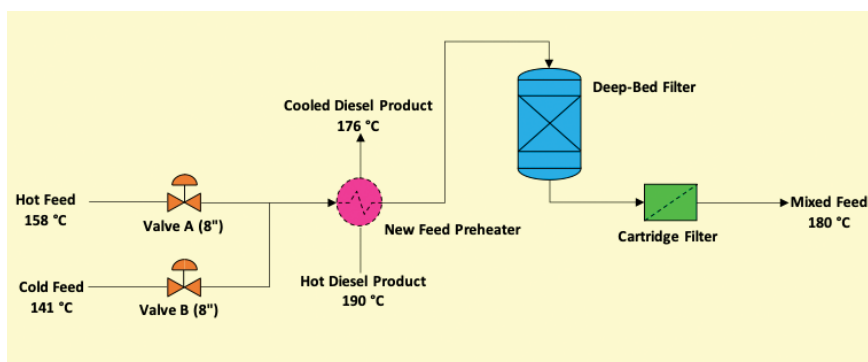

FIGURE 4. The diagram represents the hydrocracker feed system discussed in Example 1 with its new feed preheater

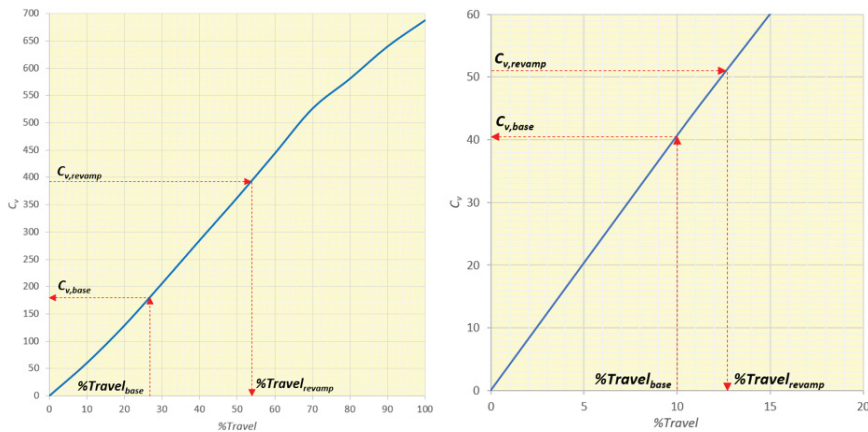

FIGURE 5. The graphs show determinations of $C_{v,base}$ and $\%Travel_{revamp}$ in Example 1. On the left is Valve A (linear – full-scale), and on the right is Valve B (equal percentage – magnified)

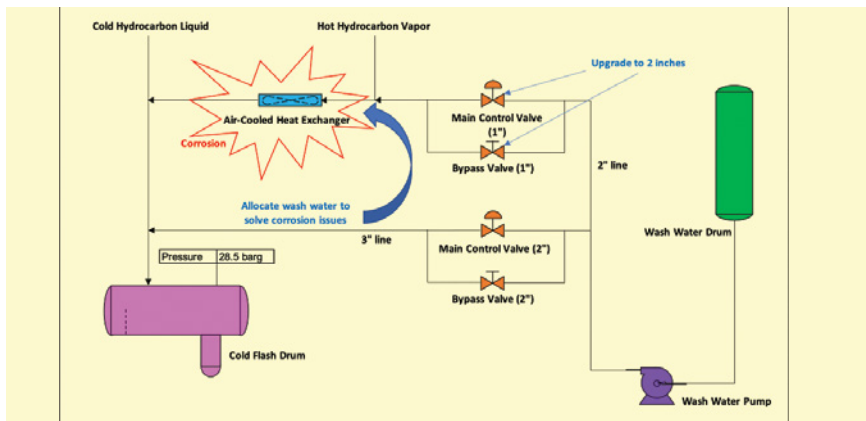

FIGURE 6. The diagram illustrates a wash-water injection system of a single-stage hydrocracker, as discussed in Example 2

The author recommends following the best practices illustrated in Figure 2 rather than using 100% paper-based calculations, which is generally a flawed practice.

In general, the revamp solution of hydraulic debottlenecking projects can be developed using the following approaches:

Smart use of equipment's characteristics.

The characteristics of the equipment or device are usually well-defined, if not subjected to severe fouling or damage, and are practically independent of the hydraulic system (such as the valve characteristic curves in Figure 3). In conjunction with good baseline data, these characteristics are more than adequate to check the hydraulic adequacy of the existing system or even design a new control valve or pump. This technique usually employs the simplest mathematical equations (flow coefficient (C_v) equation), and small amounts of process data, thus requiring mini-

mal effort. The author recommends first trying this simple yet effective technique before setting up the full-hydraulic model.

Using the fully-calibrated hydraulic model. As an initial step, a design engineer must select a proper hydraulic model. For example, the Hazen-Williams equation is usually sufficiently good to handle a water distribution system with a relatively smooth pipe surface. However, this equation is not valid for other fluids, therefore requiring the Darcy-Weisbach equation.

Whenever this approach is inevitable, a designer should systematically calibrate the hydraulic model. Typically, the modeler has to adjust multiple tuning parameters to match the actual data. These parameters include the following:

- Pipe roughness: The values

from design guidelines rarely match reality due to fouling and corrosion. This parameter is particularly crucial for cast iron or aging piping systems

- Effective pipe diameter: If the hydraulic system is subject to fouling, the modeler can also adjust the effective pipe diameter

- Resistance coefficients and equivalent lengths for piping components: Different design guidelines suggest different values (as highlighted in Table 2). Which one are you going to trust? There is no harm in tuning these parameters

As a minimum requirement, the calibrated hydraulic model should be able to fit two sets of data. If it fails to do so, it usually means the tuning parameters are inappropriate, therefore requiring recalibration. Note that a model calibration does not have to be perfect, but should be at least good enough for decision-making.

Example cases

To better understand how both approaches work, the following real-world examples are discussed here.

1. Hydrocracker feed preheater. In this example, a new feed preheater was to be designed and installed during the refinery turnaround to reduce the energy consumption of a hydrocracker unit. As illustrated in Figure 4, a mix of two liquid feed streams will be heated up by a hot diesel product from a diesel hydrotreater. Subsequently, this mixed-liquid feed stream must go through two stages of filtration to remove solid particulate matter, which can plug the front beds of the hydrocracking reactor.

This new feed preheater must fit into the existing system without causing flow-control issues. As a general guideline, Valve A and Valve B in Figure 4 should have $\%Travel$ less than 80, a typical maximum $\%Travel$ for reasonable flow control.

In this case, the refinery conducted a test run at desired revamp flowrates (Q_{revamp}) and with the filter's maximum allowable pressure

TABLE 3. TEST-RUN DATA FOR A NEW PREHEATER DESIGN

Stream	Q_{revamp} , m ³ /hour	$\%Travel_{base}$	Temperature, °C	S.G.
Hot feed	237.4	26.4	158	0.818
Cold feed	78.2	10.0	141	0.820



FIGURE 7. The location of the injection point discussed in Example 2 (highlighted by the red circle) challenges modification

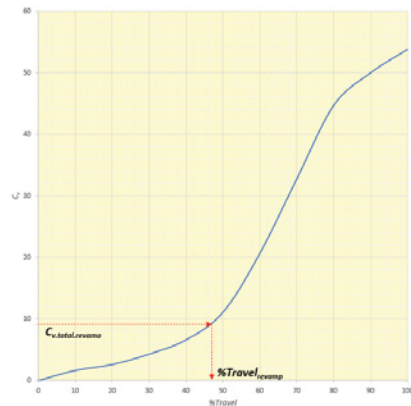

FIGURE 8. The graph shows the determinations of %Travel_revamp for a full-bore 2-in. control valve, as discussed in Example 2

drops as the worst-case scenario (see Table 3). Note that Q_{revamp} for each stream is based on the specific gravity at the corresponding operating temperature.

Instead of performing a detailed calculation, the characteristics of control valves can alternatively be utilized to save substantial effort required for the hydraulic review, as described in the following steps:

1. First, determine the baseline flow coefficient ($C_{v,base}$) from the baseline valve travel ($\%Travel_{base}$) as graphically illustrated in Figure 5. Typically, these C_v data can be obtained from vendor's literature, (for example, Fisher's Catalog 12).

2. The next step in the streamlined calculations is to find a baseline pressure drop (ΔP_{base}) using Equation 1.

$$\Delta P_{base} = (Q_{revamp}^2 S.G.) / (C_{v,base})^2 \quad (1)$$

3. After determining ΔP_{base} from Step 2, calculate a revamp pressure drop (ΔP_{revamp}) from Equation 2 based on a pressure drop of the new heat exchanger and associated piping ($\Delta P_{new\ equipment}$).

$$\Delta P_{revamp} = \Delta P_{base} - \Delta P_{new\ equipment} \quad (2)$$

4. Back-calculate a revamp flow coefficient ($C_{v,revamp}$) from Equation 3 based on ΔP_{revamp}

$$C_{v,revamp} = Q_{revamp} \times \sqrt{(S.G. / \Delta P_{revamp})} \quad (3)$$

5. Lastly, back-estimate the revamp valve travel ($\%Travel_{revamp}$), as demonstrated in Figure 5

Assuming a typical $\Delta P_{new\ equipment}$ of 1.5 bar, the calculation (estimation) results of the above steps can be summarized as per Table 4.

From Table 4, the existing system has adequate hydraulic availability to accommodate the new feed pre-heater with $\%Travel_{revamp}$ less than 80 for both Valves A and B.

Besides this case study, one can also apply this technique to similar revamps, such as adding a new adsorber/filter into the existing system.

2. Increased wash-water flow. An air-cooled heat exchanger of a single-stage hydrocracker unit suffers from ammonium salt corrosion. From a separate study, it was determined that the wash-water flowrate should be increased from 150 to 200 m³/d to correct corrosion problems by allocating wash water from another parallel injection point, as illustrated in Figure 6. As a precaution, the wash-water flowrate must be below 215 m³/d to prevent excessive erosion. For this injection point, the operating pressure is relatively con-

stant at 28.5 barg.

The whole piping system is made of a sour-service steel grade (which is expensive and requires a long lead time) and located on a high platform (Figure 7), making piping replacement unattractive.

The control and bypass valve are 1 in. (1/2-in. trim), with the line size of 2 in. for the concerned piping section. These facts suggest that one can still upgrade the control valve to accommodate more wash-water flow. It is not uncommon to see a piping system with a smaller control valve (and even smaller trim size).

Where applicable, the author recommends using the mathematical relationship proved below along with the test-run data to size the new control valve. As previously mentioned, one can always consider opening a bypass valve to overcome hydraulic limitations during the test run.

In principle, the total flow to the injection point (Q_{total}) is a sum of the flow across the main control valve (Q_{main}) and the bypass valve (Q_{bypass}) as per Equation 4.

$$Q_{total} = Q_{main} + Q_{bypass} \quad (4)$$

By employing a liquid-phase flow coefficient equation, one can rewrite Equation (4) as:

$$C_{v,total} \sqrt{(\Delta P_{total}/S.G.)} = C_{v,main} \sqrt{(\Delta P_{main}/S.G.)} + C_{v,bypass} \sqrt{(\Delta P_{bypass}/S.G.)} \quad (5)$$

In reality, all pressure-drop terms (ΔP_{main} , ΔP_{bypass} , and ΔP_{total}) are practically identical. As demon-

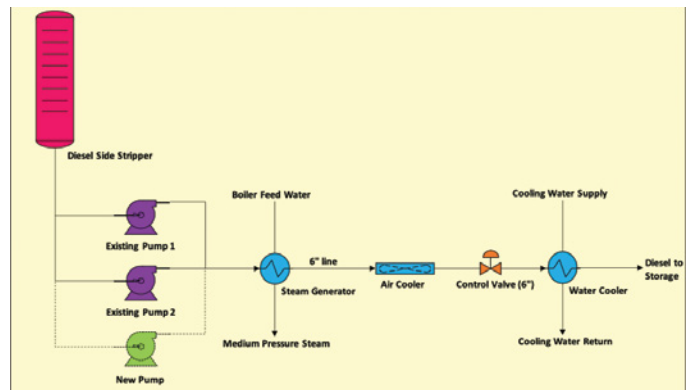

FIGURE 9. The diagram shows the scheme discussed in Example 3 of the existing diesel rundown system, with the third pump highlighted in green

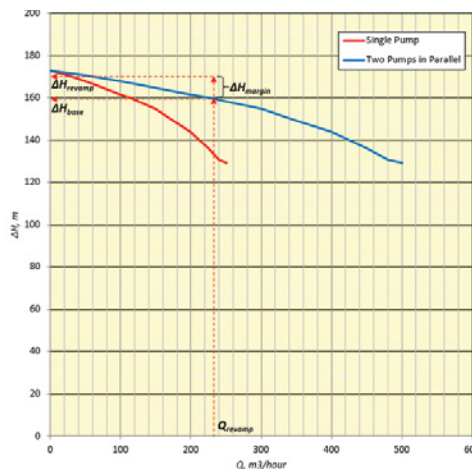

FIGURE 10. The graph shows the ΔH_{base} and ΔH_{revamp} estimate, as discussed in Example 3. A composite pump curve (blue) represents parallel operation

strated in the previous example, the designer can apply the same method to determine the flow coefficient for the main control valve ($C_{v,main}$) and bypass valve ($C_{v,bypass}$). Accordingly, one can estimate the total flow coefficient for each scenario ($C_{v,total}$) from Equation (6).

$$C_{v,total} = C_{v,main} + C_{v,bypass} \quad (6)$$

Besides liquid-phase applications, Equation 6 also applies to other applications, such as gas phase or steam. During the test run, the bypass valve was opened to explore the maximum wash-water rate at this injection point. Table 5 summarizes the test-run data and calculation results.

Although opening a bypass valve can achieve the revamp flowrate, it can also lead to undesired situations, including vessel overflow. As such, a design engineer has no choice but to upgrade the existing

TABLE 4. CALCULATION/ESTIMATION RESULTS FOR STEPS 1 TO 5					
STEP	1	2	3	4	5
Component	$C_{v,base}$	ΔP_{base}	ΔP_{revamp}	$C_{v,revamp}$	$\%Travel_{revamp}$
Valve A	180.0	1.90 bar	0.40 bar	391.8	54.0
Valve B	40.6	4.06 bar	2.56 bar	51.1	12.6

1-in. control valve. In this case, a full-bore 2-in. valve could be a good fit. From Table 5, the total flow coefficient of the revamp case ($C_{v,total,revamp}$) is 9.14. Consequently, the travel of the new control valve ($\%Travel_{revamp}$) would be 47, as highlighted in Figure 8.

3. Increased diesel production.

Diesel has the highest value among all products from a middle-distillate-oriented hydrocracker. Primarily, the petroleum refinery in this example tries to minimize the cut point between kerosene and diesel to maximize its diesel production. Unfortunately, the existing diesel pump limits the diesel production at 199.4 m³/hr from a high motor load. According to the refinery economist, the diesel production capacity should be expanded to 226.0 m³/hr (at the pumping temperature). Possible solutions include either revamping both existing diesel pumps or adding a third larger pump.

Installing one pump is obviously a less expensive solution than replacing two pumps. In the end, the refinery decided to install the third larger pump (Figure 9). This new pump will be the main workhorse, with the existing pumps as spares, and will be offline only when there is low diesel load.

As pointed out earlier, diesel is the

most expensive refinery product. Therefore, the refinery often ran both existing pumps in parallel to maximize diesel recovery. As per the design, the suction pressure of the overhead compressor directly sets the column pressure (Figure 11). The pressure-control system varies $\%Travel$ of the discharge control valve to maintain a constant accumulator pressure. When the $\%Travel$ reaches 100%, for example, at a

offline for regular maintenance. Furthermore, the liquid level inside the diesel-side stripper was sometimes unstable when the diesel hydrotreater was run at high throughput (two diesel streams from both units join together), forcing the refinery to reduce diesel production, due to the unstable level control valve. As the worst-case scenario, the design engineer conducted the test run at the design revamp flowrate (Q_{revamp} , 226.0 m³/hr) with the diesel hydrotreater at its maximum throughput. During the test run, both diesel pumps were in parallel operation, with $\%Travel$ of the level control valve at 95 (less than 80 is preferable). Based on Q_{revamp} , the baseline pump's head (ΔH_{base}) is 159.7 m, as graphically determined from Figure 10.

This diesel rundown system consists of long and complex pipelines, plus multiple heat exchangers, thus requiring challenging and expensive demolition work during the turnaround if it was modified. Hence, the new diesel pump will be sized so $\%Travel$ of the level control valve is around 60, by including a design margin (ΔH_{margin}) as per Equation 7.

$$\Delta H_{revamp} = \Delta H_{base} + \Delta H_{margin} \quad (7)$$

According to the study, the revamp pump's head (ΔH_{revamp}) must be 175.7 m to ensure good operability. In this case, a new relief valve is unavoidable due to higher shut-off pressure, but the additional cost is trivial considering the benefits.

4. Improved diesel recovery. A crude-petroleum distillation unit suffered from high pressure, resulting in lower diesel recovery. As per the design, the suction pressure of the overhead compressor directly sets the column pressure (Figure 11). The pressure-control system varies $\%Travel$ of the discharge control valve to maintain a constant accumulator pressure. When the $\%Travel$ reaches 100%, for example, at a

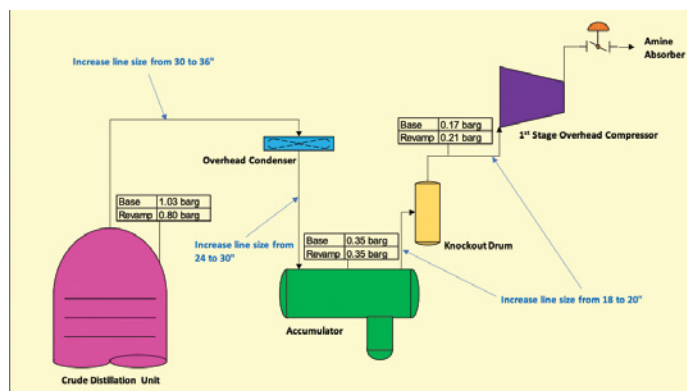

FIGURE 11. The illustration shows the crude distillation overhead system in Example 4. One can consider reducing the suction pressure drop as a fast-track solution to unload the overhead compressor, as highlighted here

TABLE 5. TEST-RUN DATA AND CALCULATION RESULTS FOR THE WASH-WATER SYSTEM REVAMP

	Base	Revamp	Maximum
Q , m ³ /hour	150.2	200.6	210
%Travel _{main}	48	91	100
%Travel _{bypass}	100	100	100
$C_{v,main}$	1.00	4.23	4.91
$C_{v,bypass}$	4.91	4.91	4.91
$C_{v,total}$	5.91	9.14	9.82

high vapor flowrate, the accumulator and column pressure become uncontrolled and increase with even higher vapor flow. In this case, there are two possible options to improve diesel recovery: revamp the overhead compressor; or reduce suction piping pressure drop.

Replacing the overhead compressor would cost several million dollars. To avoid such a costly revamp, reducing suction-piping pressure drop to free up compressor capacity may be considered. As suggested by Ref. 4, raising suction pressure is the most effective way to unload compressor capacity, compared with discharge pressure and suction temperature reduction, especially in lower-pressure applications, such as atmospheric distillation. This capacity unloading is mainly due to a reduced gas volume from higher vapor density and increased condensation at higher suction pressure.

In other words, the operating point is shifted to the left of the polytropic head curve ($\Delta H_{polytropic}$, Figure 12), so the discharge control valve can retake control, such as with %Travel less than 80.

As a first step, the design engineer conducted multiple test runs at high throughputs. Flowrate, temperature,

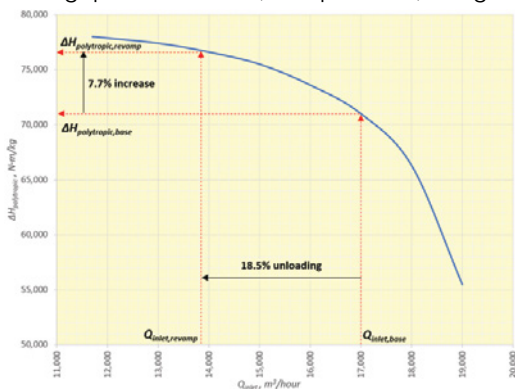

FIGURE 12. The graph shows how moving the operating point to the left of the polytropic head curve unloads the compressor discussed in example 4

pressure and stream composition were recorded and verified as recommended in the previous sections. In this case, a full hydraulic model is unavoidable. Before optimizing a revamp solution, the hydraulic model was calibrated and tested against multiple sets of test-run data to ensure its validity.

As illustrated in Figure 11, it is possible to reduce the column's top pressure by 0.23 bar at the same accumulator pressure (with a total pressure drop reduction of 0.27 bar) by upgrading piping sections on the suction side. In this case, the piping replacement costs one-sixth the cost of an overhead compressor revamp.

Additional tips

The following tips should also be considered for revamps involving hydraulic limits:

- One can always increase a pump's head by replacing the impeller. API 610 requires that the casing of a new pump should be large enough to accommodate a larger impeller, so a 5% head increase is possible.
- In contrast with general belief, the head rise to shutoff (from the rated point) could be as low as 5% for a single pump operation (and could be even lower as per Ref. 5). According to API 610, a minimum of 10% head rise is for pumps in parallel. Nonetheless, many EPC contractors adopt 10% as a design criterion for all scenarios. This misunderstanding could result in unnecessary modifications. For example, a design engineer might need to add a

relief valve into the existing system as the new shutoff pressure exceeds the piping design pressure from a sub-optimal head rise to shutoff. For revamp scenarios, the operating point tends to be on the far right of the head curve (near the maximum throughput). In other words, the operating point will not change that often, as the plant owner always tries to push the production unit to its limit. Therefore, a head

curve that is somewhat flat should be acceptable.

- Always conduct a pulsation analysis (per API 674 and 618) before adding new parallel reciprocating equipment to avoid possible piping and structural failures.
- Where can be applicable, design engineers should reuse equipment and devices that are no longer fit for their original service in a different service to minimize capital expenditures
- When engineers exploit design margins, the equipment or device will operate closer to its limits, thus narrowing operating ranges. This risk may be managed by adopting better monitoring and control, such as, adding a digital positioner to a control valve. ■

Edited by Scott Jenkins

Acknowledgements

The author would like to specially thank the following colleagues for their help in assembling this article:

- Thanawat Upienpong, Thanasan Thangchaksuwan, and Steven McMurray from PTT Global Chemical for sharing useful information, photos, and opinions.
- Wiroom Tanthapanichakoon from Global R&D and Meng Loong Chua from Shell Catalysts & Technologies for helpful comments.

References

1. Zhu, F. and others. "Efficient Petrochemical Processes: Technology, Design and Operation," Wiley, Hoboken, N.J., October 2019.
2. GPSA Midstream Suppliers, GPSA Engineering Databook, 13th Edition, 2019
3. Crane Co., Flow of Fluids Through Valves, Fittings, and Pipe, Technical Paper No. 410M, Vervante, 2009.
4. Golden, S. and others, Understanding centrifugal compressor performance, *Petroleum Technology Quarterly*, April 2002.
5. Chaware, D. and Joshi, A. Refinery specs: the user's view, *World Pumps*, February 2014.

Author



Nattapong Pongboot is an experienced chemical engineer with a broad range of experience in refining and petrochemical technologies. Before partnering with Global R&D (Address: Samut Prakarn, 10270 Thailand; Emails: nattapong.globalrd@gmail.com or nat.pongboot@gmail.com; Phone: +66-87-665-6015 (Thailand)), he held various technical roles with Honeywell UOP, PTT Global Chemical and SCG Chemicals with good exposure to process and equipment design, refinery operation, plant troubleshooting and process optimization. Additionally, he is also a technical instructor for www.chemengedu.com. He obtained both B.Eng (ChE) and M.Eng. (ChE) degree from Kasetsart University.

ONE SECOND SECOND TO NONE

Introducing the new CAFÉ Electric Valve Actuator Exclusively from Plast-O-Matic

90° actuation in as fast as one second, configurations up to 20 Nm.



STANDARD CAFÉ ACTUATOR FEATURES

- IP67 rated, corrosion-resistant glass filled polypro housing
- Multi-range, automatic multi-voltage 24-240 AC/DC
- Brushless DC motor with ICP for soft start
- Anti-condensation heater
- Manual override & torque limiter protection
- Multicolor LED status lights plus visual position indicator
- ISO 5211 mounting with interchangeable coupling for virtually any ¼ turn valve
- Premium heavy duty power board on all models
- Feedback via programmable relays
- Reverse operation Normally Open/Normally Closed
- Wiring permits drop-in replacement for most current actuators

Both models come with optional fail-safe closed, open, freeze, or pre-set position.

ADDITIONAL CAFÉ NITRO FEATURES

- Modulation 0-10 VDC & 4-20 mA
- Modulation control can be changed on the fly
- MODBUS RS-485
- Friendly user interface with 128 x 128 OLED display and full navigation keyboard
- On board timer

PLASTOMATIC

**USA Assembled
USA Engineered**

Cedar Grove, NJ & Riverside, CA • 973-256-3000 • plastomatic.com

For details visit adlinks.chemengonline.com/80076-12

Revamps and Retrofits: A Path to ‘Evergreen’ Facilities

An intelligent approach to developing the scope of retrofit projects can allow facilities to remain competitive in the marketplace and meet regulatory requirements

Alan McCurdy

Valdes Engineering (ret.)

Timely and well executed retrofit projects are critical for most facilities in the chemical process industries (CPI) as they strive to remain competitive players in the marketplace, meet the owner’s business needs and maintain regulatory compliance. Retrofit projects and new-facility projects lie on a spectrum, with the two having many similar requirements and qualities (Figure 1). With a sustainable plan and schedule, retrofit projects can be accomplished incrementally. The benefit of this approach is an “evergreen” facility that is responsive to business needs. This article focuses on scope development for revamp and retrofit projects, and presents many of the important considerations for undertaking a retrofit project.

Retrofit versus revamp

A “revamp project” replaces or upgrades equipment or systems to increase production capability or performance in an existing facility or industrial site. A “retrofit project” modifies, enhances, debottlenecks, or otherwise improves an existing entity, rather than involving the creation of an entirely new entity. In contrast, a new or “greenfield” project involves building a new facility on a new site (a greenfield), and is unconstrained by existing facilities. For the purposes of this article, these project types (retrofits and revamps) are considered identical.

Cost-benefit considerations

There are many factors at play in determining the scope, as well as the costs and benefits for a retrofit project. The following are a set of questions that should be worked through as the retrofit project begins.

Does the retrofit involve a “replacement-in-kind” of equipment?

In cases where capital equipment may need to be replaced, it is often useful to start with how long the equipment has been in service. Most capital equipment is expected to have a 20-year minimum service life. If equipment is being replaced before the expected service life, determine whether there is a deficiency in design, reliability, performance, controls or installation. Here are some possibilities to consider:

- The application might require a different type of equipment
- The required reliability might demand a different metallurgy or service factor
- The normal and peak operating requirements might exceed the equipment’s rating
- A more sophisticated control strategy might be required.



FIGURE 1. It is often the case that making improvements to CPI facilities is more cost-effective than replacing them



FIGURE 2. Improvements in equipment may require changes to the plant’s infrastructure

For example, a pump with intermittent operations might require a discharge control valve, bypass line or variable-frequency drive to minimize pump starts and stops

- The equipment installation might put excessive mechanical or hydraulic stresses on the equipment or connections. For example, high temperatures can cause significant pipe expansion, which will require expansion joints, or a design that has adequate flexibility
- For critical equipment, the schedule might require a replacement-in-kind while a longer-term solution is developed and implemented

These are only some of the factors justifying an “upgrade” instead of a “replacement-in-kind”.

Is the retrofit an upgrade or enhancement project?

If the equipment has been in service for a significant period, have there been technological improvements since the last installation? Improvements in equipment design, reliability, performance and efficiency are generally always occurring. For example, like automobiles and household ap-

pliances, industrial equipment has become automated, with significant benefits. Metallurgies have become more specialized, with alloys to reduce corrosion. Piping and electrical standards might have improved. The connecting pipe and electrical service might need to be upgraded.

Are safety or environmental performance upgrades required?

Because they are already in operation, certain processes at CPI facilities are exempt from new standards (that is, they are “grandfathered” into meeting the requirements of the new standard). However, if it is part of a retrofit project, a process might require upgrades for safety, efficiency or environmental performance. For example, environmental and reliability requirements might require some rotating equipment to have sophisticated shaft-seal systems with barrier fluids.

Have equipment manufacturers consolidated, relocated, or gone out of business?

Equipment considered “state of the art” twenty years ago, might not be available or might not meet current standards.

Will infrastructure changes be required?

Improvements of new equipment might require an upgrade of the infrastructure (Figure 2). For example, automated equipment will need data connectivity. With different metallurgies and standards, the process and utility tie-in scope might need to include more pipe, electrical or controls scope. Different equipment designs might have different footprints, with different connections, support requirements and access points. If a process is being upgraded, the decisions become more complex. The scope might require the upgrade of a system with increased or different utility requirements.

Is the retrofit project a capacity increase or a debottlenecking project?

A “bottleneck” constrains or limits a process. Bottlenecks can be identified in the manufacturing process by reviewing operating data and by modeling the process. An example is a manual drum-loading step in a manufacturing process. If a capacity increase is expected, the entire process will need to be evaluated to confirm the capacity is fea-

sible. Review the current process and facility drawings, equipment and building layouts, and hazardous area classification drawings.

Some examples of debottlenecking projects include the following: An automated bulk charging system can improve cycle times by reducing the process charging time. Installing a larger pump or heat exchanger may not provide a production increase if the process and utilities inputs and outputs do not meet the new equipment’s requirements. Keep in mind, though that higher flows might require larger pipe diameters to prevent high velocities (erosion) or high pressure drop (inefficiency). Also, heat exchangers are designed for certain fluid velocities for best heat transfer efficiency. As with piping, higher flows might require larger flow areas. Due to hydraulics and residence time, processing vessels and towers have certain high- and low-flow requirements for best operation.

Plan and scope development

The next phase of the retrofit project involves developing process flow diagrams, piping & instrumentation diagrams (P&IDs) and layout drawings of the retrofit options. “Redline” changes should be made to the existing facility design. These could include changes to piping connections for utilities, vents, drains and controls. Also note changes to valves for operation, isolation and bleeds. Consider access for construction, operations and maintenance.

The boundaries of a retrofit project need to be considered: In a retrofit project, the facility and supporting utilities are expected to be reused (with maybe selective upgrades). Otherwise, the project becomes a “new facility” project, not a retrofit. As an analogy using houses, a retro-

fit is “remodeling” not a “tear down” project. Installing more equipment in a fixed area will reduce operations and maintenance access. A larger footprint might encroach on setbacks from administrative areas and property lines. The existing facility will be reused, although the unit will likely be idled for the duration of the demolition (removal of replaced assets) and installation of new assets.

Design and execution planning

Planning is critical to any project’s success. Many of these requirements are identical to any medium-to large-sized project, whether a retrofit or new facility. The design of the new retrofit assets needs to be integrated into the operations and maintenance procedures. Otherwise, there is a risk of unintended issues and inefficiencies.

Consider the owner’s project resources. An owner has operating and maintenance staff with tasks and objectives assigned by management. Taking on project team responsibilities for a retrofit project will require a realignment of responsibilities. Engineering consultants can undertake the effort needed to support a retrofit project. However, the owner’s personnel will still need to support the consultant with operational knowledge and approve final decisions. The scope of new or reused infrastructure needs to be balanced with cost, schedule and performance.

In planning, plant engineers must be cognizant of the required design



FIGURE 3. Process outages are required to install new equipment, such as the heater shown here



FIGURE 4. Prefabricated buildings, such as the control room shown here, may be prepared off-site and installed later

standards and codes. They should ask whether there are performance and efficiency requirements for new or reused utilities, and environmental systems. Also, there may be new or tie-ins to safety systems, such as new vents or relief valves, or tie-ins to exhaust systems. The operating environment and permitted operations should also be considered for potential hazards.

Normally, a process outage is required to dismantle and remove the existing equipment before installing the new equipment (Figure 3).

Projects may require changes to plant infrastructure, so the necessary tie-ins to piping, electrical and controls and utilities should be clear, as well as the need for potential new concrete and steel buildings for the storage and warehousing of raw materials or final product. There may be a need for new environmental systems.

Infrastructure requirements

If changes to plant infrastructure are required because of a retrofit project, there are several guidelines that should be followed.

- Consider access requirements for operations and maintenance staff. Instead of ladders, platforms might be needed, for example, especially if tools and equipment are required at the access point. Davits or overhead rails might be needed for removal of equipment
- Consider the impact of the infrastructure changes to owner's and external stakeholders. Where there are impacts, contact the appropriate owner stakeholder and evaluate the

current environmental permit limits. Also, consider the current zoning of the owner's facility. Requirements waived due to grandfathering might be required for a retrofitted facility. If the amount of impervious surface is increased due to the infrastructure changes, then the stormwater runoff systems need to be evaluated

- Consider operator training and appropriate staffing levels (for startup and operations)

MoC and risk review

Whenever there are new processes being introduced or existing processes being revised, a management-of-change (MoC) approach should be used to systematically evaluate new and revised processes.

At major project milestones, safety and risk reviews should occur, particularly when making funding and permitting decisions.

Procurement

Planning is needed for the specifications, bidding and deliveries of critical equipment. The general best practice is to include the owner's purchasing agents early in the project schedule. At this stage, master service agreements and terms and conditions for the project will need to be established.

When making bid award decisions, the technical capabilities of the vendor companies involved should be carefully considered along with the pricing. Vendor construction, startup and follow-up support capabilities should be taken into account.

When assembling a procurement plan, spare-parts inventories for new equipment should be a part of the process.

Determine what items are "specialties," which would be purchased individually with specifications, and what items are treated as "bulk," meaning they can be purchased by the construction contractor.

Construction and startup

Determine the schedule for project approval, design, procurement, construction and startup. Include outage planning also for retrofit projects. New facilities can be constructed in parallel (or remotely) to

an operating facility.

For the construction schedule, the following items should be considered:

- Appropriate level of off-site pre-work may be desirable, such as skid fabrication for equipment, pipe spools, prefabricated buildings and enclosures (Figure 4)
- Consider logistics (road permits and access to the site)
- Make piping tie-ins with valves at a more convenient time during a maintenance outage
- Make electrical tie-ins during maintenance outages. For example, install a motor starter or motor control center for project motors

Remember that the construction contractor's personnel and equipment will need access to the facility for parking, administrative facilities and material laydown areas, as well as physical access for work

The level of fabrication and construction inspections is important. Normally inspections are performed by either the owner's contractors or third-party contractors. There will be documentation requirements for the owner's regulatory groups and permitting requirement for municipalities and agencies.

At the conclusion of the retrofit project construction, operations and maintenance personnel will be needed for checkout, and construction personnel are needed to resolve punch-list item resolution. In addition, vendor personnel will be needed for the startup of specialized equipment. ■

Edited by Scott Jenkins

Author



Alan McCurdy retired from Valdes Engineering Co. (100 22nd Street, Lombard, IL 60148; Email: alan.mccurdy54@gmail.com) in 2020, but remains active part-time in certain projects. He has 40 years of experience as a project manager of engineering projects in petroleum refining, chemical manufacturing, natural gas utilities and industrial facility settings. As a senior project manager at Valdes, McCurdy shepherded engineering design projects from concept to design and procurement and construction to startup. McCurdy holds a B.S.Ch.E. from Carnegie Mellon University (1976) and an MBA from the University of Louisville (1985). McCurdy has extensive knowledge of procedures and tools used by his employers, clients and associates, as well as analytics and tools from his MBA courses and quality and statistics training. In addition, McCurdy was a member of the U.S. Army from 1976 to 1980.

Gear Pump Basics

The versatile nature of gear-pump technology allows operators to handle multiple fluids in multiple applications

Michael Coburn and Geoff VanLeeuwen

PSG, a Dover company

Pump technology can be traced as far back as the B.C. era, when ancient Egyptians used a shadoof to move water from one source (in this instance, wells) to another. While basic in nature, this set the stage for others to follow, such as the ancient Greeks, who developed the first concept for a reciprocating pump, to Nicolas Grollier de Serviere, a Frenchman who created the early design for a gear pump near the back end of the 1500s.

Pump technology has substantially evolved since those times and is now woven into the fabric of everyday life.

Pumps can be found in a range of applications, such as tank trucks, ships, trains, manufacturing plants, storage tanks and bulk storage facilities, to name just a few. While water was one of the first liquids to be moved via pump, the technology has evolved to handle many other fluids. Gear pumps, for example, are designed to move an expansive range of critical commodities, including crude petroleum, biofuels, refined fuels, chemicals, solvents and food-grade materials.

While many pumping technologies have been developed and optimized throughout history, the gear pump stands out for its versatility, efficiency and longevity. These pumps, which come in internal or external designs, have endured multiple applications and fluids across time and continue to provide operators with several distinct advantages over comparable technologies.

This article discusses those advantages and explains why gear pumps remain a popular choice for operators across several sectors of

the chemical process industries (CPI) when handling a range of liquids.

A closer look at gear pumps

Gear pumps create flow by pushing liquid through a mesh of teeth from two or more rotating gears (Figure 1). A drive shaft moves one gear, and that motion moves the other gear. The rotating gears form a liquid seal inside the casing, creating a vacuum at the inlet as the gear teeth separate. Liquid flows into the space and moves around the outer edge of the gears. Once the teeth meet again by the outlet, the gears force the liquid out.

Gear pumps come with either an internal or external configuration. External gear pumps use two separate shafts to support two interlocking gears, which form a mesh at the center of the pump to move fluid along. External gear pumps are known to use either helical, spur or herringbone gears to move liquid through the pump.

A similar principle is used in the internal configuration, but with two interlocking gears of different sizes (Figure 2, left). The smaller gear rotates within the larger gear, which has cavities instead of protruding teeth. An idler pin and a bushing attached to the pump casing keep the smaller gear, also known as the idler, in an off-center position, allowing it to interlock with the external gear's cavities. A fixed, crescent-shaped spacer serves as a seal between the pump's ports and fills the void from the smaller gear's off-center position (Figure 2, right).

Consisting of few moving parts, gear pumps deliver a constant amount of liquid with each revolution of their gears, with their tight clearances and rotational speed preventing slippage during operation.

Because the gears are rigid, these pumps create a smooth, pulse-free flow, while also being fully capable of handling high-pumping pressures, a necessary trait when handling high-viscosity fluids.

Components (not) galore

When looking closer at the advantages of gear pumps over similar pump technologies, it's best to start internally (Figure 3). Gear pumps do not have many moving parts, regardless of configuration. In the external gear setup, two gears mesh to process liquid. Separate shafts support those two gears, which serve as the primary components of the pump. Internal gear pumps consist of a rotor (larger gear) and an idler (smaller gear), as well as an idler pin, bushing and a crescent-shaped partition.

In either setup, the number of components is minimal, meaning operators don't have to worry about having a massive stockpile of extra components on hand in case of failure. Having fewer components also means not having to worry about so many moving parts breaking down. Whether external or internal, both gear pump variations do not require constant shutdowns to replace different components with varying lifecycles.

When it comes to a shutdown for

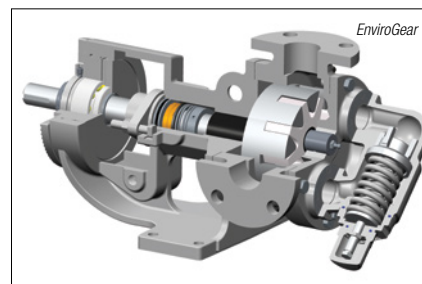

FIGURE 1. Gear pumps create flow by pushing liquid through a mesh of teeth from two or more rotating gears

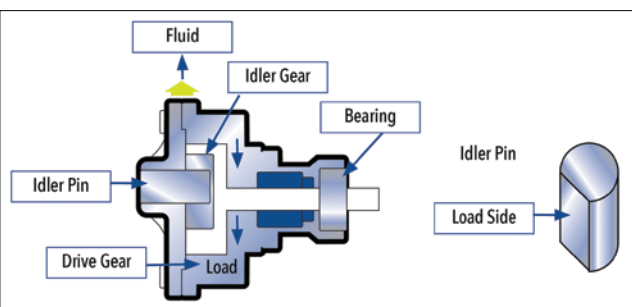
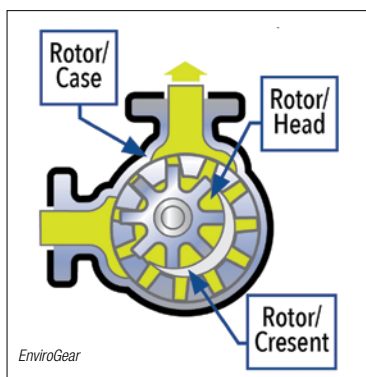

FIGURE 2. Internal gear pumps (left) have two interlocking gears of different sizes. The key components are shown in the figure at the right

the sake of maintenance, gear pump operators only have a few components to evaluate and service. This speeds up and simplifies the maintenance process, giving operators more time to focus on other tasks instead of dedicating too much time to an array of moving parts with different service requirements.

Should a component, such as a gear, fail, operators only have to open the pump and replace the part and put it back online. This is a less tedious procedure compared with other pumping technologies. Additionally, operators can service most gear pumps without removing them from the base, making it easier to service and put back online.

Tight internal clearances

When it comes to handling liquids of varying viscosities, tight internal clearances become essential to the success of the pump. Gear pumps are the kings of tight internal clearances, which makes sense given their composition. Once again, internal or external configurations create close tolerances and suction due to their design. Meshing gears do not leave any room for slippage because of the tight fit.

In gear pumps, the tightest clearances are found in the rotor/case, rotor/head and rotor/crescent mesh. Properly selected clearances insure efficient transfer of many liquids across a wide range of pressures and speeds. Aggressive liquids or liquids with solids can be accommodated in many cases by opening clearances within the pump. Examples of these include food-based products, paints and coatings, sealants, adhesives, epoxy resins, rubbers and detergents.

Some products, however, can cause major damage to pumping technology. One such substance is asphalt, which can range from a solid to a liquid, depending on the temperature, and has several fluid characteristics. Asphalt also comes in several variations, which include hot-mix asphalt, emulsified asphalt and filled asphalt.

Hot-mix asphalt can vary in viscosity based on temperature and contains a blend of high-quality aggregates, polymers and liquid asphalt cement. Emulsified asphalt is made from a mixture of asphalt cement, water and a surfactant (emulsifying agent), which makes it susceptible to shearing. Filled asphalt is highly abrasive because it contains limestone and other particles at concentrations of 60 to 70%.

While many pumps would fail at handling asphalt and its variations, gear pumps have a robust nature and appropriate internal clearances that aid in processing it. Gear pumps, though, require a break-in period to handle asphalt. After that, gear pumps can handle asphalt without damaging its components.

Robust by design

When it comes to highly corrosive fluids, many operators turn to internal gear pumps because they can be constructed to better handle them. Their design already provides an ad-

vantage, as discussed with the tight clearances. While gear pumps typically are made from stainless steel or cast iron, they are not limited to these materials.

When handling highly abrasive fluids, gear pumps can be designed using composites or alloys that allow them to process corrosive liquids, such as sulfuric acid and sodium hydroxide. Carbon steel is another option that provides the proper strength to handle aggressive liquids.

Another option to reduce costs, but not sacrifice performance is ductile iron. Using this material in gear pumps provides the same performance as steel without the costs associated with it. This is especially helpful when costs are a concern and an operator requires larger gear pumps for their application.

Steady flow

Gear pumps thrive under varying flowrates (Figure 4), allowing operators to place them in multiple applications with different demands. While some pumps need higher pressures for proper functionality or back pressure to avoid flow instability, gear pumps can function well under different flow conditions.

Gear pumps are designed to handle the same repeatable displacement regardless of the pressure. Mechanical volume displacement provides a much more repeatable fluid movement through the pressure range, providing operators with accurate flow control.

Being able to operate at varying flows means gear pumps do not suffer from the perils of constant high-flow pressures. Operators can push high flows and scale them back, de-



FIGURE 3. This breakaway diagram shows the components of an internal gear pump

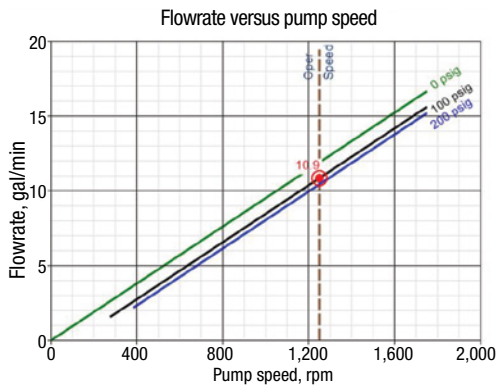

FIGURE 4. Gear pumps deliver a linear flowrate with speed over a wide range of pressure

pending on the application. The flow variation means gear pumps will not be susceptible to accelerated wear-and-tear on the pump internals from consistent high flows. The varying flows will allow the gear pump to have better longevity.

Temperatures can vary

Being able to handle a wide temperature range is imperative to pumping technology if an operator needs it for a variety of applications with different internal and external conditions. Gear pumps perform exceptionally well in nearly all temperature conditions due to having a wide range of tolerances.

Gear pumps can successfully operate in temperatures as low as -112°F (-80°C) and process fluids with temperatures as high as 800°F (425°C). Having this type of flexibility allows gear pumps to accept several liquids of varying temperatures — from soaps and surfactants to asphalts and adhesives — while also operating in environments with extreme weather fluctuations. That means that gear pumps can operate just as effectively with these fluids in the northern-most regions of Canada to the equator regions of South America.

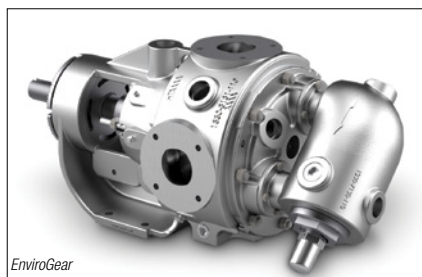

FIGURE 5. Gear pumps can be jacketed to maintain the temperature in applications such as asphalt handling

Additionally, gear pumps are designed to accept jacketing (Figure 5) across most of their surface area, a key feature that allows this technology to retain heat for substances that require it, such as asphalt. Operators can jacket up to 70–80% of the gear pump's surface area, allowing the apparatus to retain heat effectively. This means most of the gear pumps will keep hot liquids at the proper temperature without the risk of solids forming due to cold spots.

Possibilities with all viscosities

Some pump technologies are limited when it comes to the thickness or thin nature of the fluid. Gear pumps, however, can process a vast range of fluid viscosities. The interlocking gears can accept fluids as low as 1 centipoise (cP) or as high as 1,000,000 cP.

This dynamic range gives operators with gear pumps the ability to run several different fluids through them without incident. That means operators do not have to outfit a

plant with several different pumping technologies for varying fluid properties. They can rely on gear pumps to reliably and efficiently handle several different viscosities.

Edited by Gerald Ondrey

Authors



Michael Coburn is the Enviro-Gear product manager at Blackmer (1809 Century Avenue SW, Grand Rapids, MI 49503; Email: michael.coburn@psgdover.com) — PSG, a Dover company (Oakbrook Terrace, IL; www.psgdover.com). Prior to this, he has worked at Attwood Corp., Biomet Microfixation and W. Lo-

renz Surgical, He holds a B.S.M.E. degree from Grand Valley State University.



Geoff VanLeeuwen is a product management director for Blackmer and PSG. (same address as above; Email: geoff.vanleeuwen@psgdover.com). Prior to his 7 years with PSG, he worked at Sargent & Lundy and Innotec. VanLeeuwen has an M.B.A. degree from Grand Valley State University, A masters of engineering from the University of Illinois at Chicago, and a B.S.M.E. degree from Calvin College. He is a licensed Professional Engineer in Illinois and Michigan.



Reliable and efficient filtration solutions

Advanced solutions for a wide-range of industrial applications backed by a comprehensive and industry leading service support. We have nearly a century of experience in delivering filtration solutions, with legacy brands such as Larox and Pannevis.

www.mogroup.com/IndustrialFiltration

Metso:Outotec

For details visit adlinks.chemengonline.com/80076-13

Pump Seals to Manage Water

Paying attention to the seal design used in centrifugal pumps can help in water management. This article uses the beverage industry to illustrate this point

Heinz Bloch

Process Machinery Consulting

Economic survival in a climate where industry competition and environmental concerns converge is not easy. However, protecting the planet is becoming an ethical imperative for reasonable people. It is — or should be — matched only by an acute sense of self-preservation.

It gives us pleasure when we see these priorities beginning to line up nicely with legitimate and logical commercial interests. Commercial interests can rightly be summarized as low-cost production and high equipment reliability. That said, this article introduces the reader to factual details, proven achievements, and realistic goals as they pertain to the beverage industry.

Sustainability targets

In the beverage industry, targets are typically expressed as water-use ratio, or liters of water consumed per liter of beverage produced. Singling out the beer brewing industry, an entity fittingly using the acronym BIER (Beer Industry Environmental Roundtable) published benchmarking studies that show a steady improvement from 2013 to 2017 with the water-use ratio from 2.76 L/L (0.73 gal/gal) to 2.53 L/L (0.67 gal/gal) — an improvement of 8.3%.

In the beer-brewing segment of the beverage industry, the water-use ratio declined from 3.68 L/L (0.98 gal/gal) in 2017 to 3.35L/L (0.89 gal/gal) in 2018. This represents a welcome 9% reduction. However, many of today's brewers have more ambitious targets and are reaching these

by paying attention to pump-seal water-management matters.

Upgrade options

Modern breweries operate dozens of centrifugal pumps; these move liquids ranging from light slurries to ultra-clean final products. In the final products, even trace contaminants (solids) would be objectionable and proper sealing is important.

One of many possible mechanical seal configurations is generally used to seal between the pump casing and the rotating shaft. Such seals work by having two very flat surfaces, one connected to the rotating shaft, and the other connected to the stationary casing. Spring pressure is applied to one of the two faces, and pumpage cannot escape with the pump stopped and the seal faces contacting. When the pump rotates, the faces open about one micron, a gap approximately fifty times smaller than the diameter of a human hair. A minuscule volume of flush passes between the faces, thereby providing both lubrication and heat removal. For years, relatively low-cost mechanical seals similar to Figure 1 were used with water as the flush liquid.

In the decades since 1970, industry has applied the tried and tested seal configurations and seal flush applications described in the standards of the American Petroleum Institute (API). Among

these we find the typical mechanical seal in Figure 1. Here, seal flush water can be connected to the top of the outer port. This water would contact the inside of a mechanical seal assembly and then exit from a diagonally opposite port to drain. If the user opted to connect flush water to the larger of the two flush ports, the flush liquid would mingle with the liquid contained between the impeller and taper-bored pump back plate. It would thus dilute the pumpage and, in many cases, would later have to be removed by evaporative means. Vacuum dehydration or evaporation (or both) by applying heat are among the available means of water removal, but both contribute to a facility's operating expenses and wasted water, a valuable resource.

Usage figures tell the story. Suppose a user passes cool clean water through the smaller of the two flush entry ports and releases it to drain. In the brewing industry, this water flow is set to around 5.7 L/min (1.52 gal/min) per pump, which equates to about 3 million L (~800,000 gal) per pump per year. But suppose the user would be shown a well-proven way of elimi-

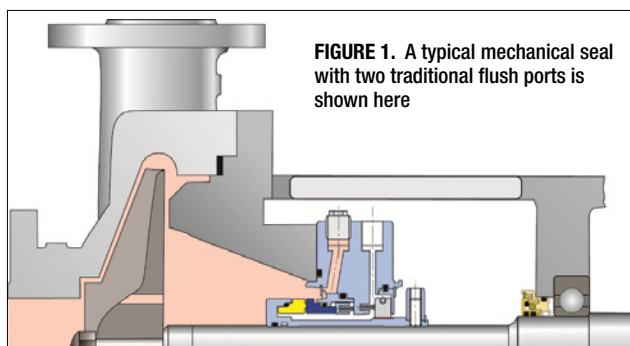

FIGURE 1. A typical mechanical seal with two traditional flush ports is shown here

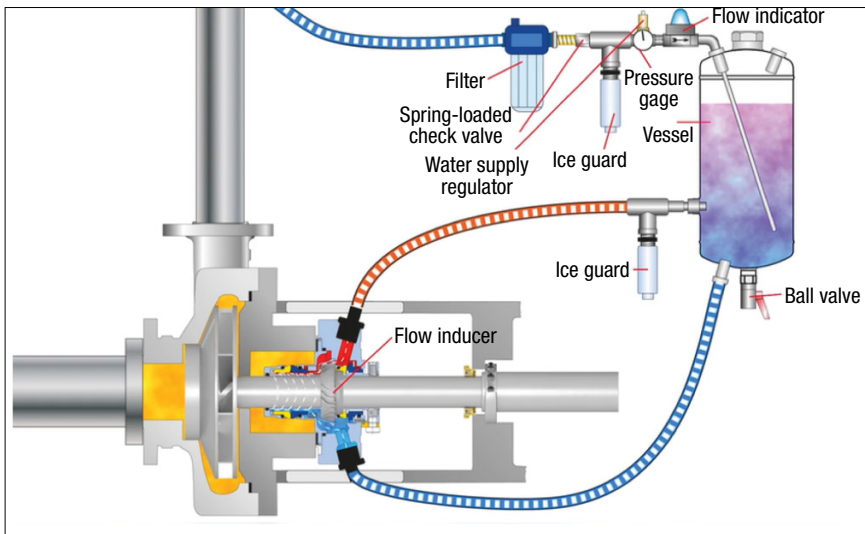

FIGURE 2. A self-contained (closed loop) seal water-management system is shown here (Source: AES-SEAL, Inc., Rotherham, UK, and Knoxville, Tenn.)

nating 5.7 L/min (1.52 gal/min) of water use from 25 pumps. The user would thereby reduce water consumption by 74.9 million L/yr (~20 million gal/yr).

We had taken the average brewery's numbers 740,812,000,000 L of water used and 221,106,000,000 L of beer produced from the BIER 2018 Benchmarking Study. The water-use ratio thus equaled 3.35. Accordingly, the new water-use ratio of 3.03 L/L translates into a reduction of 10%.

Water management systems

More recently, these reductions have been well documented [1]. The uneconomic ways of seal flushing de-

scribed earlier are being superseded by the water management system shown in Figure 2.

This is a closed-loop system that recirculates the water in the mechanical seal. The system is pressurized by the plant's water supply, ensuring that product remains in the pump. A flow indication instrument monitors system condition and readily detects leakage. Water management systems all but eliminate any significant consumption of seal water.

The vessel shown in Figure 2 is designed with a quick-release clamp allowing the bottom section of the tank to be removed for inspection and cleaning. Experienced manufacturers offer materials that are consid-

ered safe for use in food production.

Cost and potential ROI

Industry data suggest the benefits of eliminating the flow of sealing water and treatment of wastewater. Using the numbers in this article for 25 typical centrifugal pumps, yearly savings of \$113,000 will be realized. The simple payback (return on investment; ROI) on this application will be less than 12 months in addition to gaining a 10% reduction in water-use ratio. In essence, all parties — including the environment — will benefit from this proven sealing technology. ■

Edited by Gerald Ondrey

Reference

1. Perez, Robert X. and Bloch, Heinz P., "Pump Wisdom: Essential Centrifugal Pump Knowledge for Operators and Specialists," 2nd Ed., John Wiley & Sons, Hoboken, N.J., 2021.

Author



Heinz P. Bloch is a consulting engineer at Process Machinery Consulting, and resides in Montgomery, Tex. (heinzpbloch@gmail.com). His professional career commenced in 1962 and included long-term assignments as Exxon Chemical's Regional Machinery Specialist for the U.S. He has authored or co-written over

790 publications, among them 24 comprehensive books on practical machinery management, failure analysis, failure avoidance, compressors, steam turbines, pumps, oil mist lubrication and optimized lubrication for industry. Bloch holds B.S. and M.S. degrees (cum laude) in mechanical engineering from the New Jersey Institute of Technology. He is an ASME Life Fellow and was awarded life-time registration as a Professional Engineer in New Jersey.



PUMP & FILTRATION SYSTEMS >

PELLETIZING & PULVERIZING SYSTEMS >

RECYCLING SYSTEMS >

DIGITALIZATION >

MAAG Group is the partner for chemical applications industry worldwide. All our integrated solutions from Pump and Filtration systems to Pelletizing and Pulverizing systems and to Recycling systems have outstanding performance for demanding customer requirements.

MAAG Group
a **DOVER** company

maag.com



NEXT LEVEL SOLUTIONS

Integrated Systems for Industrial and Chemical Applications

Critical Components in Regenerative Thermal Oxidizers: High-Cycle Valves

When designing a regenerative thermal oxidizer, engineers should not overlook the high-cycle valves that control process air and help maintain efficiency

Anu D. Vij

Ship & Shore Environmental

Regenerative thermal oxidizers (RTOs) are regularly utilized in the chemical process industries (CPI) to collect and control air-pollution emissions generated from industrial manufacturing operations. RTOs are specially designed for controlling emissions of volatile organic compounds (VOCs) from a broad spectrum of industries. An RTO uses ceramic media as the heat-exchanger medium, providing high heat recoveries. For the last decade, a great deal of emphasis has been placed on the selection of the ceramic media and burners for RTOs, while some of the most critical components of RTO operation — high-cycle valves — have been overlooked.

The purpose of high-cycle valves in an RTO is to provide tight shutoff of the process air to maintain destruction and removal efficiency (DRE) and proper heat-exchanger operation for thermal energy recovery. High-cycle valves serve to regulate the flow of air and to isolate ducting and equipment for maintenance without interrupting other connected units. Without this valve, the regenerative process is unattainable.

High-cycle valve designs should consider the maximum system pressure, temperature changes and stresses imposed by the connecting ducting so as to prevent distortion and misalignment of the sealing surfaces. The sealing surfaces should be of such material and design that the valve will supply a tight seal over a reasonable service period. Proper valve design is critical for high VOC destruction efficiency over a long equipment life. Cycling more than 200,000 times per year, RTO high-cycle valves must operate reliably and must seal to less than 0.1% leakage at full system pressure.



FIGURE 1. This two-canister regenerative thermal oxidizer (RTO) is equipped with high-cycle horizontal poppet valves

High-cycle valve types

Generally, two kinds of valves are used in RTOs. High-cycle valves are connected directly to the RTO's heat-exchanger canisters, directing the flow of process air into and out of the canisters, which need to open and close every few minutes (typically 1 to 3 minutes) on a continuous basis. Most other valves associated with RTOs are called low-cycle valves due to their lower cycling frequency. Examples of low-cycle valves include isolation and diverter valves.

This article focuses exclusively on high-cycle valves, which are critical to the overall performance of an RTO — namely to achieving high destruction efficiencies. Figure 1 depicts a typical two-canister oxidizer with high-cycle horizontal poppet valves.

RTO designs can be classified into three categories: single-canister, odd-canister and even-canister designs. The style of high-cycle valve used is determined by the canister design. Some commonly available high-cycle valve designs used in RTOs include the following:

- Butterfly valves (including single-blade, dual-blade and dual-seat valves)

- Poppet valves (including single-poppet, dual-poppet and four-way poppet valves)
- Single-canister rotary valve
- Two-canister, high-cycle, rotating-flow reversal indexing valve

Other important issues to consider when selecting high-cycle valves for RTO applications include the following:

- Valve seat material — options include metal-to-metal seats or ceramic (soft)
- Valve actuation mode — options include hydraulic, pneumatic or electric
- Maximum allowable leakage rate — typically 0 to 0.25%
- Materials of construction
- Resistance to condensable organics and other particulate matter

High-cycle butterfly valves

High-cycle butterfly valves (Figure 2) have been used in RTOs for more than 40 years. Consisting of a heavy-gauge flat plate inserted into a gas stream, the high-cycle valve plate is rotated by means of a motor (actuator) and linkage to control the gas-stream flow. When the valve is in the fully open position, the flat plate is aligned with the direction of gas flow and, therefore, provides very little flow restriction.

Butterfly valves occupy less space than any other valve style and have broad versatility due to the virtue of their design. They are relatively tight-sealing when proper torque is applied. They offer a simple and reliable means of gas control for both modulating and on-off applications.

To actuate (for opening or closing), butterfly valves employ a center-mounted rotating disc (or discs that typically rotate 90 deg.) The solid rotating disc, which is generally round, must resist thermal and mechanical deformations. The type and size of the valve dictates the torque

requirements and, by extension, the actuation requirements. For example, beyond a certain torque, pneumatic actuators become less desirable than hydraulic dampers due to their size.

Butterfly valves used in regenerative thermal oxidizers typically are the on-off type with two design variations.

The single-blade valve is the most common type. It consists of a single solid disc (or blade) that seats against a metal or a compressible-bulb (ceramic) seal.

The double-blade valve is used when zero leakage is required, usually in applications where very high destruction efficiencies are desired. Double-bladed dampers also are supplied with either a metal or a ceramic seat.

High-cycle poppet valves

Throughout the U.S. and in Europe, poppet valves have been used for over 25 years in two- and multi-canister RTOs. They consist of a flat circular plate that is raised or lowered typically by an electrical or pneumatic actuator. When the flat plate is in the closed position, it provides a gas seal by pressing against a raised circular seat. Gas attempting to pass through the cylinder is blocked. When the valve disk moves laterally, there are 12 to 24 in. between its open and closed position. Note that poppet valves are used for on-off control only — they are not appropriate for modulating applications (Figure 3).

Poppet valves were initially developed for service in fabric filter systems or baghouses, and later successfully applied to RTOs. Fabric filter systems require two-way service with poppets either open or closed. System-outlet poppets are single-disc, low-leak models. System bypass poppets are leak-free, and employ a double blade and seat with seal air. These valves range from 20 to 60 in. in diameter for industrial baghouses and 48 to over 96 in. in diameter for power-generation baghouses.

Poppets for RTO service are more complex in that they seal multiple gas paths while diverting gas in different directions. RTO systems designed with two-way poppets should have one inlet and one outlet damper, providing fail-safe conditions during power outages and upset operating



FIGURE 2. High-cycle butterfly valves used in RTOs will employ a flat valve plate that is mechanically rotated to control gas flow

conditions. RTO poppet valves of this type are driven pneumatically or electrically for high-cycle service and low-leakage isolation. Pneumatics or electric drive systems supply the most reliable type of drive movement for service where 200,000 cycles per year are expected. Poppets of this type operate best when oriented vertically. They are also available with zero-leak blades and seats.

Poppet valves with three-way and four-way configurations have also been used in RTO systems. A three-way poppet has one inlet and two outlets. It cycles between two seats, diverting flow through one while sealing the other and vice versa. A four-way poppet has two inlets and two outlets, and is typically used in compact RTO systems.

Single-canister rotary valves

The single-canister rotary valve design eliminates the need for separate inlet, outlet and purge valves by replacing them with a single large valve. Rotary valve designs have been applied to RTOs for over 20 years. The sequence of the multiple-valve bed function as an inlet, outlet or purge is achieved by the rotation of this single

valve. This valve is located below the heat recovery chambers and is either electrically or hydraulically driven. The rotation of the valve, or the flow distributor, continuously controls the airflow from the inlet plenum to one-half of the heat exchange media through the combustion retention chamber, through the other half of the heat exchange media, and then out through the outlet plenum.

The cylindrical canister holds 12 pie-shaped heat-recovery chambers. The air is cycled through six inlet chambers for preheating and through six outlet chambers for reheating the heat exchanger bed before exiting. Before chambers switch from inlet to outlet flow, they are purged of any residual unoxidized gas. Between each set of heat-recovery chambers, there are two additional chambers. One of these chambers is closed off while the second is used to purge. This purging ensures minimal VOC spikes and maximizes destruction efficiency.

The single valve moves at several minutes per rotation and ensures a smooth transition from inlet-to-purge to outlet-to-purge. This reduces upstream pressure fluctuations, which are more typical with traditional individual-canister RTO designs. The single valve, in some instances, depending on the type of traditional valve-drive system, requires less maintenance compared to the multiple-valve RTO system.

However, a single-canister rotary valve utilizes a machined metal-to-metal surface (sealed air-floating rings are used to minimize metal-to-metal contact) to achieve tight seal-



FIGURE 3. High-cycle poppet valve systems are designed for on-off control, rather than modulating applications



FIGURE 4. A flow-reversal indexing valve provides a zero-leakage design that utilizes a high-pressure air seal

ing. This makes it more susceptible to wear and tear. This seating arrangement also makes the single-canister RTOs more susceptible to particulate contamination, resulting in lost performance over time due to inorganic particulate wearing on the machined metal-to-metal surfaces. Other problems, such as shaft bushing malfunction and metal deformation due to high temperatures hitting the valve, have also been reported.

Flow-reversal indexing valves

The high-cycle poppet and single-canister rotary-valve system is made up of many moving parts. All of these reciprocating parts must be driven simultaneously during the valve shaft's 0.5- to 1.0-s linear seat-to-seat sudden start/stop valve movement. A simple wear-based failure of even one of these many pneumatic electro-mechanically driven parts, such as a pneumatic cylinder seal failure or pneumatic component temperature freeze, can cause the entire system to malfunction. At worst, the entire RTO system goes down, or at a minimum, poppet seat leakage reduces VOC destruction beyond the point of destruction compliance during its 200,000 valve cycles per year.

Conversely, another valve type — high-cycle flow-reversal indexing valves — can offer zero leakage in an assembly that has only one moving part. Each 90-deg index rotation of the shaft-interconnected

flow diverter assembly reverses flow through the valve and interconnected RTO system. Simply put, each rotational valve movement (typically less than 0.5 s) reverses flow through the RTO.

Indexing valve designs feature no VOC leakage seals and no stopping contact seats. Rather, they are sealed using high-pressure air, which is supplied by an integral compressor blower, whose clean air separates the inlet and exhaust sides of the valve (Figure 4). This valve requires no duct manifolds, as the valve is equipped with one duct-mounting flange on each of its four ports — a valve duct connection to the inlet port from the process; an exhaust port duct to the stack; a port duct to chamber 1; and a port duct to chamber 2.

Indexing rotation is supplied by a single, intermittently operated electric-motor drive system that uses electrical power for 0.5 s per movement. It is preprogrammed for same-direction 90-deg indexing of the diverter assembly on contact

closure command, which ensures that it always stops at its same predestinated position each time, even after a utility power failure. Electrically, all that is required by the end user is a momentary contact closure to initiate movement. If so desired, as an option, it can also be same-direction rotated using a single pneumatic cylinder. ■

Edited by Mary Page Bailey

Author



Anu D. Vij is chief operating officer (COO) of Ship & Shore Environmental Inc. (2474 N. Palm Drive, Signal Hill, CA 90755; Phone: (562) 997-0233; Email: avij@shipandshore.com; Website: www.shipandshore.com). Vij has over twenty years of experience in the environmental, chemical, petrochemical and air-pollution-control industries, and has specific expertise in thermal oxidation technologies. As COO at Ship & Shore, he oversees several business units, including sales, finance, engineering, project management, procurement, production and services. Prior to joining Ship & Shore, Vij served as vice president, enclosed combustion systems, at Aereon and was director of engineering at On-Quest Inc. Vij holds an M.S.Ch.E. from the University of Southern California and a B.S.Ch.E. from Panjab University in India.

Xcellence has a new name. Dürr and Dürr Megtec have streamlined and unified their product portfolio to offer you the most effective air pollution control technologies on the market. Let us manage your environmental compliance, so you can stay focused on your business. www.durr-megtec.com

For details visit adlinks.chemengonline.com/80076-22

HOT PRODUCTS



Vertical Cartridge Filter (VCF) For Industrial Dust Collection

The Schenck Process Vertical Cartridge Filter (VCF) is a pulse jet filter designed to handle medium to high air volumes for industrial dust removal. It is typically used as a nuisance dust collector in applications with light dust loads and a high volume of air flow. An easy-to-use cartridge clamp system on the hinged front doors of the baghouse provides easy access to and rapid replacement of the filter media. This minimizes downtime during scheduled maintenance decreasing overall cost of operation.

A robust design adds to the overall stability of the filter. Each unit is constructed with reinforced carbon steel that is rated for 6.4 psi Pred.

www.schenckprocess.com

For details visit adlinks.chemengonline.com/80076-23



High-Performance Gas Cleaning, Emission Control and Gasification Solutions from Beltran Technologies

Beltran Wet Electrostatic Precipitator Systems are specified for cleaning a wide range of gas streams. WESP's are used for metallurgical processing operations and sulfuric acid gas cleaning. WESP's are also used downstream from wet or dry flue gas desulfurization units, which cannot capture fine particulates and acid aerosols. They are superior on high ash content and sticky residues (which may also contain mercury and heavy metals), oily residues/tars, mercury (as condensed oxide), emissions from municipal solid waste (MSW) in waste-to-energy applications and biomass syngas cleaning.

- Ultralow emission of submicron particulate, acid mist and visible plumes
- Advanced modular design—minimized field assembly, flexible configuration
- Available in corrosion-resistant alloys, conductive composites or FRP construction

Beltran Technologies, Inc.

www.beltrantechnologies.com

For details visit adlinks.chemengonline.com/80076-24

BUYER'S guide 2022

Featured Product & Service Providers



INSIDE:

Company Directory	48
Corporate Profiles	52
Products & Service Index	56
Liquid, Gas and Air Handling	64
Solids Handling	72
Electrical Power Generation & Transmission	75
Instrumentation & Controls	77
Processing Equipment	82
Engineering Materials	96
Plant Maintenance & Personnel Safety	98
Design, Engineering & Construction	100
Information Technology	102
Environmental Services	105
Process Chemicals	107

WE ARE INNOVATORS

Solutions to adversity are made of ideas.

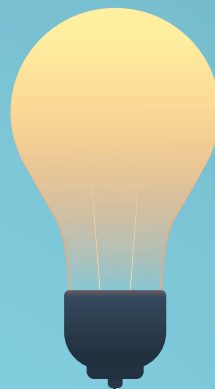

... and we are only one Team!

Global network harmony and cooperation
are the multipliers for **POMPETRAVAINI GROUP**
Energy and efficiency.

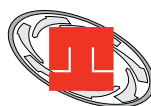

pompetravaini

For details visit adlinks.chemengonline.com/80076-19

Pompetravaini Spa

Via per Turbigo, 44 • 20022 Castano Primo (Mi)

Tel. +39.0331.889000 • Fax +39.0331.889057

vendite@pompetravaini.it • www.pompetravaini.com



A

A-VAC INDUSTRIES, NC., 1845 S. Lewis St., Anaheim, CA 92805 (714-938-1300; FAX: 714-938-0899)

AAHANA Giffard Systems, Dynamostraße 13, Mannheim., Baden-Württemberg, Germany 68165 (+49 (0) 621 4385-5189; FAX: +49 (0) 621 43855-555; info@aahanagiffard.com; www.aahanagiffard.com)

With more than 48 years of experience, our skilled engineering team uses the latest innovations in design technology to give you the highest quality product at the lowest possible cost. We regularly compliance with ASME, PED, CRN, GOST, DOSH, AS1210.

ABB INC., 3700 West Sam Houston Parkway South, Houston, TX 77042 (1-800-HELP-365; FAX: 440-585-7071; contact.center@us.abb.com; www.abb.com/chemical)

PAUL O. ABBE, 201 Hanson Ct. Suite 125, Wood Dale, IL 60191 (630-350-3012; FAX: 630-238-7584)

— See our ad on page 15

ACCA Pumps, PO Box 1216, Katy, TX 77492 (281-576-7722)

ACS Industries Inc., 1 New England Way, Lincoln, RI 02865 (4017694700; FAX: sales@acsind.com)

Admix Inc., 144 Harvey Road, Londonderry, NH 03053 (603-627-2340; FAX: 603-627-2019; admixsales@admix.com; www.admix.com)

Admix mixers deagglomerate powders into primary particles & eliminate fisheyes while reducing overall batch times. We can help with the emulsion & dispersion of ceramics, polymers, plastics, adhesives, resins, polyols, and many other compounds.

Agriculture silicono adjuvant, No.6, Tianhong Road, Xinghuo industry zone, Youngxiu, Jiujiang, Jiangxi, China 330319 (13767196417)

AHED Software, C/Castillo de la Concepcion 14, Lorquí, Murcia, Spain 30564 (+34 968 676 157)

AIR MONITOR CORPORATION, 1050 Hopper Ave., Santa Rosa, CA 95403 (1-800-AIRFLOW; FAX: 707-526-9970; www.airmonitor.com)

AMANDUS KAHLE GmbH & Co. KG, Dieselstr. 5-9, Reinbek, Germany 21465 (+49 (0)-40-72-771 0; FAX: +49 (0)-40-72-771 100; www.akahl.com)

AMERICAN ELEMENTS, Los Angeles, CA 90024 (310-208-0551; FAX: 310-208-0351; www.americanelements.com)

— See our ad on back cover

Ameritechology, 280 N Midland Ave #180, Saddle Brook, Hackensack, NJ 07663 (2012587300; FAX: 973-244-1244)

Ametek Fluoropolymer Products, 42 Mountain Avenue, Nesquehoning, PA 18240 (570-645-6917; FAX: 570-645-6950; info.fpp@ametek.com; www.ametekfpp.com)

AMETEK Land, Stubley Lane, AMETEK Land, Dronfield, United Kingdom S8 1DJ (01246 417691; FAX: +44 1246 410585)



ANDRITZ SEPARATION, ANDRITZ AG, Stattegger Strasse 18, Graz, Austria 8045 (+43 050 8050; separation@andritz.com; www.andritz.com/separation)

Antea North America, 15260 Hwy 105 West, Houston, TX 77356 (888-642-6832)

AOC Resins, 955 Highway 57 East, Collierville, TN 38017 (901-854-2800; FAX: 901-854-1183; sales@aoc-resin.com; www.aoc-resins.com)

APPLIED FLOW TECHNOLOGY (AFT), 2955 Professional Place, Suite 301, Colorado Springs, CO 80904 (719-686-1000; www.aft.com)

ARCA Regler GmbH, Kempener Str. 18, Toenisvorst, Germany 47918 (49-2156-7709-0; FAX: 49-2156-770955)

ARKEMA INC., 900 First Avenue, King of Prussia, PA 19406 (610-205-7000; FAX: 610-205-7913)

— See our ad on page 3

ASPEN TECHNOLOGY, INC., 20 Crosby Dr., Bedford, MA 01730 (781-221-6410; FAX: 781-221-6410; www.aspentech.com)

AUMA RIESTER GMBH & CO. KG, Aumastrasse 1, Muellheim, Germany 79379 (+49 7631 8091250; www.auma.com)



AUTOMATION PRODUCTS INC. (DYNATROL DIV.), 3030 Maxroy St., Houston, TX 77008 (713-869-0361; FAX: 713-869-7332; sales@dynatrolusa.com; www.dynatrolusa.com)

B

B&P LITTLEFORD, 1000 Hess Avenue, Saginaw, MI 48601 (989-757-1300; FAX: 989-757-1301; www.bplittelford.com)

Badger Meter, Inc., P.O. Box 245036, Milwaukee, WI 53224-9536 (414-355-0400; FAX: 414-371-5932; www.badgermeter.com)



BELTRAN TECHNOLOGIES, INC., 1133 East 35 Street, Brooklyn, NY 11210 (718-338-3311; FAX: 718-253-9028; info@beltrantechnologies.com; www.beltrantechnologies.com)

Beltran Technologies has become the first name in advanced gas cleaning & air pollution emission control for a broad spectrum of industrial processes, metallurgical and sulphuric acid production.

BENKO PRODUCTS, INC., 5350 Evergreen Pkwy., Sheffield Village, OH 44054 (440-934-2180; FAX: 440-934-4052; www.benkoproducs.com)

BENTLEY SYSTEMS INC., 685 Stockton Drive, Exton, PA 19341 (610-321-6470)

BERNDORF BAND GROUP, Leobersdorferstr. 26, Berndorf, Austria 2560 (43-2672-800-0; FAX: 43-2672-84176; www.berndorfband-group.com)

BEUMER GROUP GMBH & CO. KG, Oelder Str. 40, Beckum, Germany 59269 (+49 2521 240; FAX: +49 2521 24280; www.beumergroup.com)

BIAR SAMPLING SYSTEMS, 2506 S. Philippe Ave., Gonzales, LA 70737 (225-647-4300; contact@biar.us; www.biar.us)

Specialized manufacturer of sampling systems for grab sampling, including inline sample valves and top of reactor recirculation loop for hazardous liquids or gas. We help plant improve Safety, Industrial Hygiene & Environment and Sample Quality.

Biazzi SA, 25 ch de la Tavallaz, P.O. Box 84, Chailly/Montreux, Switzerland 1816 (41-21-989-2121; FAX: 41-21-989-2120; www.biazzi.com)

Bionomic Industries Inc., 777 Corporate Dr., Mahwah, NJ 07430-2008 (201-529-1094; FAX: 201-529-0252; sales@bionomicind.com; www.bionomicind.com)

Bionomic Industries is the proven global leader in providing innovative cost effective systems for control of multipollutant air emissions, recovery of valuable product and waste heat in the chemical industry.



BLUE-WHITE INDUSTRIES, 5300 Business Drive, Huntington Beach, CA 92649 (714-893-8529; FAX: 714-895-9492; sales@blue-white.com; www.blue-white.com)

BOERGER GMBH ROTARY LOBE PUMPS, Benning-sweg 24, Borken-Wesese, Germany 46325 (+49 2862 9103-0; FAX: +49 2862 9103-46; www.boerger.com)

BRONKHORST HIGH-TECH BV, Nijverheidsstraat 1A, Ruurlo, Netherlands NL-7261AK (+31 573458800; www.bronkhorst.com)

Buchiglas USA Corp., 15 Michael ave, Suite 1, Farmingdale, NY 11735 (631-912-2300; info@buchiglas-usa.com; www.buchiglas-usa.com)

Buchiglas (Buchi AG) is a globally leading Swiss manufacturer of reactor systems and pilot plants for the chemical and pharmaceutical industry as well as research institutions – from lab, through pilot, to production scale.

Buerkert Fluid Control Systems, Christian-Buerkert-Str. 13-17, Ingelfingen, Germany 74653 (+49 7940 10-0; FAX: +49 7940 10-91 204)

Bungartz GmbH & Co. KG, Paul, Duesseldorfer Strasse 79, Duesseldorf, Germany 40545 (0049 211 57 79 05 - 0)

BUSCH VACUUM SOLUTIONS, 516 Viking Dr., Virginia Beach, VA 23452 (800-872-7867; FAX: 757-463-7407; www.buschvacuum.com)

BUSS-SMS-CANZLER GMBH, Kaiserstr. 13-15, Butzbach, Germany 35510 (49-6033-85-0; FAX: 49-6033-85-249)

BUTTING Group, Gifhorner Strasse 59, Knesebeck, Germany 29379 (+49 5834 50-0; www.butting.com)

C

Caloris Engineering, 8649 Commerce Drive, Easton, MD 21601 (410-822-6900)

Capovani Brothers Inc., 704 Prestige Parkway, Scotia, NY 12302 (518-346-8347; FAX: 518-381-9578)

CASHCO, INC., P.O. Box 6, 607 W. 15th, Ellsworth, KS 67439-0006 (785-472-4461; FAX: 785-472-3539; www.cashco.com)

CAST-X Circulation Heaters, 1310 Kingsland Dr., Batavia, IL 60510 (630-482-5325; jawe@castaluminumolutions.com; www.castaluminumolutions.com)

CAST-X Circulation Heaters from Cast Aluminum Solutions can heat flammable liquids & gases (solvents, cryo-gases, hydrocarbons etc.) including high purity apps. CAS also makes custom-engineered heated components for critical chemical & gas processes

Catalytic Products International Inc., 980 Ensell Road, Lake Zurich, IL 60047 (847-438-0334)

CHECK-ALL VALVE MFG. CO., 1800 Fuller Rd., West Des Moines, IA 50265 (515-224-2301; FAX: 515-224-2326; www.checkall.com)

CHEMICAL PROCESS ENGINEERING SERVICES - AFFILIATED ENGINEERS (AEI), 5802 Research Park Boulevard, Madison, WI 53719 (6082361222)

CHEMSTATIONS, INC., 11000 Richmond DR, Suite 580, Houston, TX 77042 (713-978-7700; FAX: 713-978-7727; www.chemstations.com)

— See our ad on page 9

CLEAVER-BROOKS, INC., 221 Law Street, Thomasville, GA 31792 (229-226-3024; FAX: 800-250-5883; www.cleaverbrooks.com)

COLLINS INSTRUMENT CO INC., P.O. Box 938, Angleton, TX 77516 (979-849-8266; FAX: 979-848-0783; www.collinsinst.com)

COMESSA, 101 rue du Rhin-Napoléon, Strasbourg, France 67100 (33-3-88-79-41-41; FAX: 33-3-88-79-02-04)

Conval, Inc., 96 Phoenix Avenue, Enfield, CT 06082 (860-749-0761; FAX: 860-763-3557)

COPERION / COPERION K-TRON, 606 North Front Street, Salina, KS 67401 (17858251611; www.coperion.com)

Cortec Corp., 4119 White Bear Pkwy., St. Paul, MN 55110 (651-429-1100; FAX: 651-429-1122; productinfo@cor-tecvci.com; www.cortecvci.com)



CR CLEAN AIR, Six Campus Drive, Parsippany, NJ 07054 (973-947-8787; FAX: 908-232-2146; info@crleanair.com; www.crleanair.com)

CR CleanAir's engineered systems have been designed to address nearly any emissions challenge. We scrub gasses others won't touch.



CROLL REYNOLDS CO. INC., Six Campus Drive, Parsippany, NJ 07054 (908-232-4200; FAX: 908-232-2146; info@croll.com; www.croll.com)

Since 1917, Croll Reynolds has been a leader in the research, design, and manufacture of vacuum process systems. We design, install, and maintain Ejector Systems, Combination Liquid Ring/Ejector Systems, Thermocompressors, and Vacuum Chillers.

CURTISS-WRIGHT EST GROUP, 2701 Township Line Rd., Hatfield, PA 19440 (215-721-1100; FAX: 215-721-1101)

D

DECHEMA E.V., Theodor-Heuss-Allee 25, Frankfurt am Main, Germany 60486 (49-69-75-64-0; FAX: 49-69-75-64-201; www.dechema.de)

— See our ad on page 22



DEDERT CORPORATION, 17740 Hoffman way, Homewood, IL 60430 (708-747-7000; c.crankshaw@dedert.com; www.dedert.com)

Dedert has helped clients optimize their business across the world since 1968 with a complete range of advanced liquid and powder processing solutions.

Det-Tronics, 6901 W 110th St., Bloomington, MN 55438 (952-941-5665)

Dickow Pump Co., 1738 Sands Pl., S.E., #200, Marietta, GA 30067 (770-952-7903; FAX: 770-933-8846; www.dickow.com)

DURR SYSTEMS, INC., 26801 Northwestern Highway, Southfield, MI 48033 (248-450-2000)

DÜRR SYSTEMS, INC., 830 Prosper Street, WI 54115 (920-336-5715; www.durr-megtec.com)

— See our ad on page 43

Durr Universal, Inc., 1925 Highway 51 - 138, Stoughton, WV 53589 (888-300-4272; www.durr-universal.com)

DYNAMIC AIR INC., 1125 Willow Lake Blvd., St. Paul, MN 55110-5193 (651-484-2900; FAX: 651-484-7015; www.dynamicair.com)

DYNATEK Loading Systems, 200 North Harrison Street, North Prairie, WI 53153 (888-853-5444; FAX: 262-392-2984; garyk@dynatekloadingsystems.com; www.dynatekloadingsystems.com)

E

EASTMAN, 575 Maryville Centre Drive, Saint Louis, MO 63141 (800-433-6997)

EDWARDS US HEADQUARTERS, 6416 Inducon Drive West, Sanborn, NY 14132 (800-848-9800; FAX: 866-484-5218)

EKATO, 48 Spruce Street, Oakland, NJ 07436 (201-825-4684 ext. 205)

— See our ad on page 84

EKATO RUEHR- UND MISCHTECHNIK GMBH, Hohe-Flum-Str.37, Schopfheim, Germany D-79650 (+49 7622 290; FAX: +49 7622 29 213; www.ekato.com)

— See our ad on page 84

EMERSON, 1100 W. Louis Henna Blvd. Building One, Round Rock, TX 78681 - 74 (800 833 8314)

ENDRESS & HAUSER INC, 2350 Endress Place, Greenwood, IN 46143 (317-535-7138; FAX: 317-535-8498; www.endress.com)

EnsueworX, 119 6 Ave SW #101, Calgary, AB, Canada T2P 0P8

ENTEX Rust & Mitschke GmbH, Heinrichstraße 67a, Bochum, NRW, Germany 44805 (+49 (0)234 89 122-0; FAX: +49 (0)234 89 122-99; www.entex.de)

Environmental C&C, 21 Dunham Place, St. Charles, IL 60174-5795 (630-443-0751)

EPIC Systems Group, 6006 Wickwood road, Peoria, IL 61614 (314-312-3370; marketing@epicsysinc.com; www.epicmodularprocess.com)

F

FCI FLUID COMPONENTS INTERNATIONAL LLC

FCI-FLUID COMPONENTS INTERNATIONAL, 1755 La Costa Meadows Dr., San Marcos, CA 92078 (760-744-6950; FAX: 760-736-6250; eflow@fluidcomponents.com; www.fluidcomponents.com)

Filtration Technology Corporation, 11883 Cutton Road, Houston, TX 77006 (713-849-0849; sales@ftc-houston.com; www.ftc-houston.com)

Since 1987, Filtration Technology Corporation (FTC) has built a reputation for developing and delivering innovative products at the forefront of separation technology.



FIN TUBE PRODUCTS, INC., 188 S Lyman St., Suite 100, Wadsworth, OH 44281 (330-334-3736; FAX: 330-334-3848; mb@fintube.com; www.fintube.com)

FLEXICON CORPORATION, 2400 Emrick Blvd., Bethlehem, PA 18020-8006 (610-814-2400; FAX: 610-814-0600)

Flottweg SE, Industriestr. 6 - 8, Vilsbiburg, Germany 84137 (49-8741-301-0; FAX: 49-8741-301-300; www.flottweg.com)

FLUID LINE PRODUCTS INC., 38273 Western Pkwy., P.O. Box 1000, Willoughby, OH 44096 (440-946-9470; FAX: 440-946-9472; www.fluidline.com)

Fluitron, Inc., 30 Industrial Dr., Ivyland, PA 18974 (215-355-9970; FAX: 215-355-9074; info@fluitron.com; www.fluitron.com)

FOX THERMAL, 399 Reservation Road, Marina, CA 93933 (831-381-4300; www.foxthermal.com)

FRITSCH GmbH - Milling and Sizing, Industriestrasse 8, Idar-Oberstein, Idar-Oberstein, Germany 55743 (+49 6784 70-150)

FRITSCH Milling & Sizing, Inc., 57 Grant Drive, Suite G, Pittsboro, NC 27312 (919-229-0599)

G

Gas & Air Systems, Inc., 1304 Whitaker Street, Hellertown, PA 18055 (610-838-9625; FAX: 610-838-9650)

GEA GROUP, 9165 Rumsey Road, Columbia, MD 21045 (800-722-6622; www.gea.com)

— See our ad on page 23

Gebrueder Loedige Maschinenbau GmbH, Elsener Str. 7-9, Paderborn, Germany 33102 (05251-3090; FAX: 05251-309123)

GEMCO, the worldwide mixing and drying authority, 301 Smalley Avenue, Middlesex, NJ 08846 (800-654-3626; www.ogemco.com)

— See our ad on page 16

GEMU Valves, Inc., 3800 Camp Creek Parkway, Building 2600 Suite 120, Atlanta, GA 30331 (678-553-3400; FAX: 404-344-9350)



GORMAN-RUPP PUMPS, P.O. Box 1217, Mansfield, OH 44901-1217 (419-755-1011; FAX: 419-755-1251; gr-sales@gormanrupp.com; www.grpumps.com)
Gorman-Rupp pumps are constructed to handle the tough corrosive and abrasive chemicals that other pumps can't handle. You'll find our pumps handling chemicals in canneries, tanneries, automotive and chemical plants.

H

HAPMAN, 6002 East N Avenue, Kalamazoo, MI 49048 (269-343-1675; FAX: 269-349-2477; sales@hapman.com; www.hapman.com)

Heat Transfer Research, Inc. (HTRI), P.O. Box 1390, Navasota, TX 77868 (979-690-5050; FAX: 979-690-3250)

HEMCO Corporation, 711 South Powell Road, Independence, Missouri 64056 (816-796-2900; FAX: 816-796-3333)

Hengfengtai Precision Machinery Co., Binhai Industrial Zone road10, 1489, Wenzhou, China 325025 (+86 15994268384)

Hermetic-Pumpen GmbH, Gewerbestr. 51, Gundelfingen, Gundelfingen, Germany 79194 (49-761-5830-0; www.hermetic-pumpen.com)

HighChem Co. Ltd., Tokyo Toranomon Global Square 11th floor, 1-3-1, Toranomon, Minato-ku, Japan 105-0001 (818033685382; FAX: 81352518576)

HONEYWELL, 101 Columbia Rd., Morristown, NJ 07962 (973-455-2000; FAX: 973-455-5722)

HONEYWELL PROCESS SOLUTIONS, 1250 W Sam Houston Pkwy S, Houston, TX 77042 (832-252-3500; www.honeywellprocess.com)

HRS Process Systems Ltd., 201/202, Karan Selene, 851, Bhandarkar Road, Pune, India 411004 (+91 20 2566 3581; FAX: +91 20 2566 3583; mkcom@hrsasia.co.in; www.hrsasia.co.in)

HTE GMBH - THE HIGH THROUGHPUT EXPERIMENTATION COMPANY, Kurfalzring 104, Heidelberg, Germany D-69123 (+49 (0) 62 21.74 97 - 0; FAX: +49 (0) 62 21.74 97 - 137; www.hte-company.de)

I

ISAFE MOBILE GMBH, i Park Tauberfranken 10, Lauda-Koenigshofen, Germany 97922 (+49 9343 601480)

INDECK POWER EQUIPMENT CO., 1111 Willis Ave. (CE), Wheeling, IL 60090 (847-541-8300; FAX: 847-541-9984; www.indeck.com)

— See our ad on page 15

INEOS Electrochemical Solutions, Bankes Lane Office, Bankes Lane, Runcorn, Cheshire, United Kingdom WA7 4JE (+44.1928.517.823)

IPCO GERMANY GMBH, Saliestr. 35, Fellbach, Germany 70736 (+49 711 5105 0)

J

JAYGO, INC., 7 Emery Ave., Randolph, NJ 07869 (908-688-3600; FAX: 908-688-6060)

JENIKE & JOHANSON INC., 400 Business Park Dr., Tyngsboro, MA 01879-1077 (978-649-3300; FAX: 978-649-3399)

JLS INTERNATIONAL, INC., 381 Fawn Lane, West Jefferson, NC 28694 (336-877-5571; FAX: 336-877-5579)

JOHN ZINK HAMWORTHY COMBUSTION, 11920 East Apache Street, Tulsa, OK 74116 (918-234-2800; FAX: 918-234-1800)

K

KAESER COMPRESSORS, INC., PO Box 946, Fredericksburg, VA 22404 (800-981-6888; FAX: 540-898-5520; info.usa@kaeser.com; us.kaeser.com/chemeng)

Kaeser Compressors is an industry leader in providing the chemical industry with superior compressed air and vacuum systems. Our broad product line includes rotary screw air compressors, blowers, dryers, filters, storage, piping, & system controls.

Kelvion, Meesmannstr. 103, Bochum, Germany 44807 (+49 234 980-0; www.kelvion.com)

Kemperle Industries - Digital Design, NY, New York, NY



KNF NEUBERGER, INC., 2 Black Forest Rd., Trenton, NJ 08691-1810 (609-890-8600; knfusa@knf.com; www.knfusa.com)

Koch Modular Process, 45 Eisenhower Drive, Suite 350, Paramus, NJ 07652 (201-267-8670; FAX: 201-368-8989)

KOCH-GLITZCH, INC., 4111 E. 37th St. N., Wichita, KS 67220 (316-828-5110; FAX: 316-828-7985)

— See our ad inside front cover

KOERTING HANNOVER GMBH, Badenstedter Str. 56, Hannover, Germany 30453 (0511-2129-0; FAX: 0511-2129-223)

— See our ad on page 69



Komline-Sanderson Corp., 12 Holland Ave., Peapack, NJ 07977 (908-234-1000; FAX: 908-234-9487)

— See our ad on page 67

Krohne, Inc., 55 Cherry Hill Drive, Beverly, MA 01915 (978-535-6060; FAX: 978-535-1720)

L



Energizing Chemistry

LANXESS CORPORATION, 111 RIDC Park West Drive, Pittsburgh, PA 15275 (412-809-1000; info@lanxess.com; www.lanxess.us)

LAUDA DR. R. WOBSEER GMBH & CO. KG, Pfarrstrasse 41/43, Lauda-Koenigshofen, Germany 97922 (+49 (0)9343 503-0; FAX: +49 (0)9343 503-222; info@lauda.de; www.lauda.de)

LEWA GmbH, Ulmer Str. 10, Leonberg, Germany 71229 (49-7152-14-0; www.lewa.com)

LOAD CONTROLS, INC., 53 Technology Park Rd., Sturbridge, MA 01566 (508-347-2606; FAX: 508-347-2064) — See our ad on page 12

M

MACROTEK INC., 421 Bentley St. Unit 1, Markham, ON, Canada L3R 9T2 (905-415-1799)

MAN Energy Solutions SE, Steinbrinkstraße 1, Oberhausen, Germany 46145 (+49 (0)208-69201; FAX: +49 (0)208-692021)

MATERIAL TRANSFER & STORAGE INC., 1214 Lincoln Rd., P.O. Box 218, Allegan, MI 49010-0218 (269-673-2125; FAX: 269-673-4883; www.materialtransfer.com)

MATHWORKS, 1 Apple Hill Drive, Natick, MA 01760-2098 (508-647-7000; FAX: 508-647-7001; www.mathworks.com)

Method Competency Register, Davis Crescent, Luton, United Kingdom SG5 3RB (01462 713313)

Method Process Safety Training, HAZOP, LOPA and Consultancy, Davis Crescent, Luton, United Kingdom SG5 3RB (+44(0)1462 713313)

Metsu Flow Control Inc, Vanha Porvoontie 229, Vantaa, Finland, Finland 1301 (+358 20 483 150; FAX: +358 20 483 151; www.metsu.com/valves)

METSO MINERALS INDUSTRIES, INC., 2715 Pleasant Valley Road, York, PA 17402 (717-843-8671; FAX: 717-845-5154; www.metsu.com)

— See our ad on page 39

METTLER-TOLEDO PROCESS ANALYTICS, 900 Middlesex Turnpike, Building 8, Billerica, MA 01821 (800 352 8736; FAX: 781-301-8701)

METTLER-TOLEDO, LLC, 1900 Polaris Pkwy., Columbus, OH 43240-4518 (1-800-METTLER; FAX: 614-438-4518)

Mokon, 2150 Elmwood Ave., Buffalo, NY 14207 (716-876-9951; FAX: 716-874-8048; sales@mokon.com; www.mokon.com)

For 65 years, Mokon has set the standard in the design and manufacture of high-quality thermal fluid systems to accurately control process temperatures from -20°F to 700°F (-29°C to 371°C). Our products are proudly designed and manufactured in USA.

Munson Machinery Company, Inc., 210 Seward Avenue, Utica, NY 13502-5750 (315-797-0090; FAX: 315-797-5582; info@munsonmachinery.com; www.munsonmachinery.com)

Myers Mixers, 8376 Salt Lake Ave, Cudahy, CA 90201 (323-560-4723; FAX: 323-771-7789)

MYRON L COMPANY, 2450 Impala Drive, Carlsbad, CA 92010 (760-438-2021; FAX: 760-931-9189; www.myronl.com)
— See our ad on page 20

N

NEL HYDROGEN, 10 Technology Drive, Wallingford, CT 06942 (203-949-8697; FAX: 203-949-8016)

NEUHAUS NEOTECH Maschinen- und Anlagenbau GmbH, Fockestraße 67, Ganderkesee, Germany D-27777 (+49 (0)4221 859 0; www.neuhaus-neotech.de)

Niagara Transformer Corp., 1755 Dale Road, Buffalo, NY 14225 (716-896-6500; FAX: 716-896-8871)

Nol-Tec Systems, Inc., 425 Apollo Dr., Lino Lakes, MN 55014 (651-780-9600; FAX: 651-780-4400; sales@nol-tec.com; www.nol-tec.com)

Nordfab Ducting, 150 Transit Avenue, Thomasville, NC 27360 (800-532-0830; FAX: 336-889-7873; info@nordfab.com; www.nordfab.com)

O

OHL Guterth Industrial Valves GmbH, Helmershaeuser Strasse 9 + 12, Altenstadt, Germany 63674 (+49 6047 8006 0; FAX: +49 6047 8006 29; www.ohl-guterth.de)

OILTECH srl, Via Cavaglia, 3, Milan (MI), Italy 20139 (390256808705; FAX: 39025392197)

Orival Water Filters, 213 S Van Brunt St., Englewood, NJ 07631-9902 (201-568-3311; FAX: 201-568-1916; filters@orival.com; www.orival.com)

P

Pacific Dust Collectors & Equipment, 16200 SE Van Zyl Dr, Damascus, OR 97089 (844-732-4327; www.pacificdust-equipment.com/)

Palamatic Process Inc, 1510 Cecil B Moore Ave, Suite 200, Philadelphia, PA 19121 (215-498-9303)

PARATHERM – HEAT TRANSFER FLUIDS, 2009 Renaissance Boulevard, King of Prussia, PA 19406 (610-941-4900; FAX: 610-941-9191)



PARR INSTRUMENT COMPANY, 211 53rd Street, Moline, IL 61265 (309-762-7716; FAX: 309-762-9453; lisa.randolph@parrinst.com; www.parrinst.com)

Parr designs and manufactures high quality chemical reactors, pressure vessels, high pressure tubular reactors, custom designed reactor systems, calorimeters, combustion vessels, and related equipment developed specifically for laboratory use.

PCE Instruments UK Ltd, Unit 11 South Point, Ensign Way, Hamble, Southampton, Hampshire, United Kingdom SO31 4RF (+44 (0) 2380 987030; FAX: +44 (0) 2380 987039)

Pentair, 4301 W. Davis, Conroe, TX 77304 (936-788-1000; separations@pentair.com; www.pentairseparations.com)

PEPPERL+FUCHS SE, Lilienthalstrasse 200, Mannheim, Germany 68307 (+49-621-776-0; FAX: +49-621-776-1000; www.pepperl-fuchs.com)

Pfeiffer Vacuum GmbH, Berliner Strasse 43, Asslar, Germany 35614 (+49-6441-802 0; FAX: +49-6441-802 1202; www.pfeiffer-vacuum.com/)

Pfeiffer Vacuum, Inc., 24 Trafalgar Square, Nashua, NH 03063 (800-248-8254; FAX: 603-578-6550; www.pfeiffer-vacuum.com/)

Phoenix Contact GmbH & Co.KG, Flachsmarktstr. 8, Blomberg, Germany 32825 (+49 (0)5235-300; www.phoenixcontact.com)

PICK HEATERS INC., 730 S. Indiana Ave., P.O. Box 516, West Bend, WI 53095 (262-338-1191; FAX: 262-338-8489; www.pickheaters.com)

PINK GMBH THERMOSYSTEME, Am Kessler 6, 97877 Wertheim, Germany (0049-9342-919-0; FAX: 0049-9342-919-11 1; www.pink.de)

PLAST-O-MATIC VALVES INC., 1384 Pompton Ave., Cedar Grove, NJ 07009-1095 (973-256-3000; FAX: 973-256-4745)

— See our ad on page 33

POMPETRAVAINI SPA, via per turbigo 44, Castano Primo, Italy 20022 (+39 0331 889 000; FAX: +39 0331 889 057)

— See our ad on page 47



POPE SCIENTIFIC, INC., P.O. Box 80018, 351 N. Dekora Woods Blvd., Saukville, WI 53080 (262-268-9300; FAX: 262-268-9400; info@popeinc.com; www.popeinc.com)

Pope Scientific manufactures chemical processing equipment, engineered systems & laboratory apparatus for distillation, separation, purification & mixing applications. Lab, pilot & large-scale production sizes. Toll processing & feasibility testing.

POSI-FLATE, 1125 Willow Lake Blvd., St. Paul, MN 55110-5193 (651-484-5800; FAX: 651-484-7015; www.posiflate.com)

PRM Filtration, 200 20th Street, Raleigh, NC 27509 (888-873-2848; shop.prmfiltration.com)

PROCESS

ENGINEERING ASSOCIATES, LLC

"Excellence in Applied Chemical Engineering"

PROCESS ENGINEERING ASSOCIATES, LLC, 700 South Illinois Ave., Suite A-202, Oak Ridge, TN 37830 (865-220-8722; FAX: 865-220-8729; info@processengr.com; www.processengr.com)

PROCO PRODUCTS, INC., 2431 N. Wigwam Dr., Stockton, CA 95205 (209-943-6088; FAX: 209-943-0242; www.procoproducts.com)

Q

Quickly Prepare, Plug And Repair Leaking Heat Exchanger, Condenser and Boiler Tubes, 2701 Township Line Rd. 19440 (215-721-1100)

R

R. STAHL, Am Bahnhof 30, Waldenburg, Germany 74638 (+49 (0) 7942-943-0; FAX: +49 (0) 7942-943-4333; www.r-stahl.com)

REMBE GMBH SAFETY + CONTROL, Gallbergweg 21, Brilon, Germany 59929 (+49 2961 7405-0; FAX: +49 2961 50714; www.rembe.de)

REMBE INC., 3809 Beam Road Ste K, Charlotte, NC 28217 (704-716-7022; FAX: 704-716-7025)

Roots Systems, Inc., 2711 Gray Fox Road, A315, Monroe, NC 28110 (832-598-7680; FAX: 704-282-4305)

ROSS MIXERS, 710 Old Willets Path, P.O. Box 12308, Hauppauge, NY 11788-0615 (631-234-0500; FAX: 631-234-0691; www.mixers.com)

S

SAINT-GOBAIN NORPRO CORP., 3840 Fishcreek Road, Stow, OH 44224 (330-673-5860; FAX: 330-677-7245; www.saintgobain.com)

SAP FILTER PVT LTD, Plot No. A- 5, Sector- 1, The Vasai Taluka Indl. C, Mumbai, Maharashtra, India 401208 (9167970213; FAX: 91 250 2458982; sapfilters@gmail.com; www.sapfilter.com)

SAP FILTERS PVT LTD has made a mark in manufacturing and exporting a spectrum of filtration equipment. Its product range is renowned for its quality and durability.

SARTORIUS - CHEMICAL & CONSUMER CARE, Otto-Brenner-Straße 20, Goettingen, Germany 37079 (+49-(0)551 3084756; www.sartorius.com/chemicals)

SCHENCK PROCESS, 7901 NW 107th Terrace, Kansas City, MO 64153 (816-891-9300; FAX: 816-891-8336; www.schenckprocess.com)

SEEQ CORPORATION, 1301 2nd Avenue, Ste. 2850, Seattle, WA 98101 (206-801-9339)

SENTRY EQUIPMENT CORP, 966 Blue Ribbon Circle North, Oconomowoc, WI 53066 (262-567-7256; FAX: 262-567-4523)

SEW-EURODRIVE PTE. LTD., No 9, Tuas Drive 2, Jurong Industrial Estate, Singapore, Singapore 638644 (+65 68621701; FAX: +65 68612827)

Shijiazhuang Langrong Chemical Co., Ltd, No. 298 Zhonghua N Avenue, Hebei, Shijiazhuang, China 50000 (+86-311-87713810; FAX: +86-311- 87713815)

SICK, INC., 6900 West 110th Street, Bloomington, MN 55438 (800-325-7425; www.sick.com)

SICK is one of the world's leading manufacturers of sensors, customized systems, and services for analysis and process measurement technology. The diversity of its product line allows SICK to offer solutions at every phase of production.

SIEMENS AG, Siemensallee 84, Karlsruhe, Germany D-76187 (+49(0)721/595-0; www.siemens.com)

SIEMENS PROCESS INSTRUMENTATION, 2060 Detwiler Road, Suite 111, Harleysville, PA 19438 (800-365-8766; piabu-requestinformation.industry@siemens.com; www.usa.siemens.com/pablog)



SIERRA INSTRUMENTS, INC., 5 Harris Ct., Bldg. L, Monterey, CA 93940 (831-373-0200; FAX: 831-373-4402; info@sierrainstruments.com; www.sierrainstruments.com)

SPX Flow Technology, 4647 S.W. 40th Ave., Ocala, FL 34474 (353-873-5793; FAX: 352-873-5770)

Stedman Machine Company, 129 Franklin Street, Aurora, IN 47001 (812-926-0038; FAX: 812-926-3482)

Strobic Air Technologies, 140 W. Orvilla Road, Lansdale, PA 19446 (215-723-4700; FAX: 215-723-7401)

SULZER CHEMTECH, Neuwiesenstrasse 15, Winterthur, Switzerland 8401 (41522623722; www.sulzer.com)

SWAGelok CO., 29500 Solon Road, Solon, OH 44139-2764 (440-248-4600; www.swagelok.com)

T

Tek-Trol LLC, 796 Tek Drive, Crystal Lake, IL 60014 (847-857-6076)

Thayer Scale, 91 Schoosett Street, Pembroke, MA 02359 (1-855-7THAYER; FAX: 781-826-7944; sales@thayerscale.com; www.thayerscale.com)

Thayer Scale is the pioneering developer of continuous weighing and feeding equipment for the dry solids conveying and processing industries. Our equipment provides that rare combination of precision measurement and extreme reliability.

Thermal Care, 5680 W Jarvis Ave, Niles, IL 60714 (847-966-2260; FAX: 847-966-9358)

Thermal Fluid Systems Inc., 3046 Matlock Drive, Kennewick, WA 98541 (704-425-5556; FAX: 770-425-9559; sales@tfsheat.com; www.tfsheat.com)

THYSSENKRUPP INDUSTRIAL SOLUTIONS AG, thyssenkrupp Allee 1, Essen, Germany 45143 (49-201 8440; info.industrial-solutions@thyssenkrupp.com; www.thyssenkrupp-industrial-solutions.com)

TLV CORPORATION, 13901 S. Lakes Dr., Charlotte, NC 28273 (704-597-9070; FAX: 704-583-1610; www.tlv.com)

— See our ad on page 65

Toray Membrane USA, Inc., 13435 Danielson Street 92064 (858-218-2360; FAX: 858-218-2380)

Tuthill Vacuum & Blower Systems, 4840 W. Kearney Street, Springfield, MO 65803-8702 (417-865-8715; FAX: 417-865-2950)

Tylok Fittings & Valves, 1061 E 260th St, Cleveland, OH 44132 (216-261-7310; FAX: 216-261-7317; www.tylok.com)

U

UIC INC., 1225 Channahon Rd., P.O. Box 863, Joliet, IL 60434-0863 (815-744-4477; FAX: 815-744-1561; warmstrong@uicinc.com; www.uicinc.com)

UNIFLUX / EXOTHERM CORP., 31369 Nichols Sawmill Road, Magnolia, TX 77355 (713-981-9100; FAX: 713-981-7081; info@exotherm.com; www.exotherm.com)

— See our ad on page 57



UNIVERSAL FLOW MONITORS, INC., 1755 E. Nine Mile Rd., Hazel Park, MI 48030 (248-542-9635; FAX: 248-398-4274; ufm-sales@flowmeters.com; www.flowmeters.com/products)

Universal Flow Monitors manufactures flow monitors ideal for most fluids and gases. We offer vortex shedding, variable area, DP laminar flow, electromagnetic and turbine technologies, providing local rate display, transmitters and switches.

V

VACUUBRAND, INC., 11 Bokum Rd., Essex, CT 06426 (860-767-5341; www.vacuubrand.com)

Valcor Engineering Corp, 2 Lawrence Road, Springfield, NJ 08753 (973-467-8400)

VEGA AMERICAS, INC., 4170 Rosslyn Drive, Cincinnati, OH 45209 (513-272-0131; FAX: 513-272-0133; www.vega.com)

VEGA GRIESHABER KG, Am Hohenstein 113, Schiltach, Germany, Germany 77761 (+49 7836 50-0; www.vega.com)

VESCONITE BEARINGS, 77 Mimetes Rd, Denver, Johannesburg, Rep. of South Africa 2094 (+27 11 616 111; FAX: 713-574-7255; vesconite@vesconite.com; www.vesconite.com)

Vortex, 1725 Vortex Avenue, Salina, KS 67401-1768 (785-825-7177; FAX: 785-825-7194)

W

Wabash Power Equipment Co., 444 Carpenter Ave., Wheeling, IL 60090-0427 (847-541-5600; FAX: 847-541-1279; info@wabashpower.com; www.wabashpower.com)

Waste-to-Energy, Salt Lake City, 2 Dawn Hill, Salt Lake City, UT 84092 (360-961-4624)

Water Heating Direct, 3209 Galvez Ave, Fort Worth, TX 76111 (401-552-4328)

WELLAND & TUXHORN AG, Gütersloher Str. 257, Bielefeld, Germany 33649 (+49 521 9418-0; FAX: +49 521 9418-156; www.welland-tuxhorn.de)

Wenck Associates, Inc., 7500 Olson Memorial Hwy, Suite 300, Golden Valley, MN 55427 (763-252-6800; FAX: N/A)

WYSSMONT COMPANY, INC., 1470 Bergen Blvd, Fort Lee, NJ 07024 (201-947-4600; FAX: 201-947-0324)

X

XCHANGER, INC., 1401 S. 7th St., Hopkins, MN 55343 (952-933-2559; www.xchanger.com)

Y

Yokogawa Corporation of America, 12530 W Airport Blvd, Sugar Land, TX 77478 (281-340-3800; FAX: 770-254-1337)

YSTRAL GMBH, Wettelbrunner Str. 7, Ballrechten-Dottingen, Germany 79282 (+49 7634 5603 900; www.ystral.com)

Z

Zeeco, Inc., 22151 E. 91st St., Broken Arrow, OK 74014 (918-258-8551; FAX: 918-251-5519)

ZIRCAR Refractory Composites Inc., P.O. Box 489, Florida, NY 10921 (845-651-2200; FAX: 845-651-1515)

ZOOK ENTERPRISES, 16809 Park Circle Drive, Chagrin Falls, OH 44023 (440-543-1010)



FREE On Demand Webinars

View On Demand
Webinars at
[chemengonline.com/
webcasts](http://chemengonline.com/webcasts)

Chemical Engineering magazine produces webinars on topics of critical importance to the chemical process industries. It's not too late to participate in a live webinar or download any of the on demand webinars at chemengonline.com/webcasts

American Elements

American Elements
10884 Weyburn Ave.
Los Angeles, CA 90024
Telephone: 310-208-0551
Email: customerservice@americanelements.com
www.americanelements.com



THE WORLD LEADER IN ADVANCED MATERIALS

American Elements is the world leader in engineered & advanced materials with a catalogue of over 16,000 materials including advanced polymer additives and dopants, high purity metals, chemicals, semiconductors and minerals, nanoparticles, organo-metallics and crystal-grown materials for commercial applications such as plastics, resins, ultra light and ultra strong composites and alloys, ceramics and compounds for automotive, aerospace, military, medical, electronic, green/clean technologies and solar energy applications. American Elements maintains research and laboratory facilities in the U.S. and manufacturing/warehousing in the U.S., Europe, China & Brazil.

ENGINEERED MATERIALS ON A COMMERCIAL SCALE

Since our production begins at the mine in our mineral refining and chemical separations operations in China, Mexico and the U.S., your cost will remain as low as your specifications demand. The combination of world class U.S. based research, development,



analysis and certification with a fully integrated global manufacturing operation allows us to both certify to the highest possible U.S. standards and at the same time provide materials at the lowest possible world prices.

The company's over 35,000 page online catalog is annually viewed by more than 1.2 million visitors and more than 30,000 Twitter followers.

American Elements' thousands of customers include 30 percent of the Fortune 50 list of America's largest corporations and all U.S. national labs and military branches.

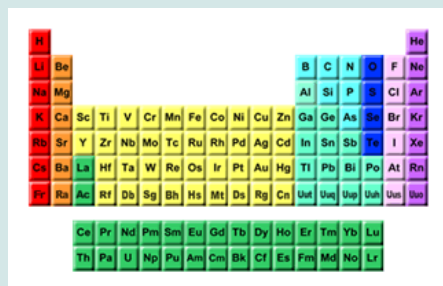

A PASSION FOR SCIENCE

American Elements' Academics & Periodicals Department supports materials science education at the high school, college and graduate school levels. The company co-sponsored a four-part PBS series on NOVA titled "Making Stuff" examining the world of materials science. Over the last twelve months alone, American Elements has co-sponsored 140 industry and academic conferences in 25 countries in fields such as electronics, aerospace, medical/pharmaceutical, optics and advanced military technology.



Exotherm Corporation

Exotherm Corporation
 31369 Nichols Sawmill Road
 Magnolia, TX 77355
 Phone: 713-981-9100
 Fax: 713-981-7081
 E-mail: info@exotherm.com
www.exotherm.com

UNIFLUX/EXOTHERM

Exotherm Corporation is a leader in providing custom designed fired heaters to the chemical processing and oil and gas processing industries.



CONVECTION HEAT TRANSFER

Exotherm's Uniflux Convection Heater was developed fifty years ago to overcome the problems of overheating and degrading heat sensitive process fluids that customers experienced with their existing fired heaters.

The Uniflux Convection Heater is custom designed for processes requiring 100,000 to 70,000,000 Btu/hr absorbed duty. The heater is designed to utilize the circulation of high velocity exhaust gases around the process tubes to produce convective heat transfer. This heat transfer is uniform around the periphery of the process tubes. The result is lower tube wall and film temperatures compared with the radiant heat transfer method used in most heaters.

The Uniflux Convection Heater is custom designed for processes requiring 100,000 to 70,000,000 Btu/hr absorbed duty. The heater is designed to utilize the circulation of high velocity exhaust gases around the process tubes to produce convective heat transfer. This heat transfer is uniform around the periphery of the process tubes. The result is lower tube wall and film temperatures compared with the radiant heat transfer method used in most heaters.

NO FLAME IMPINGEMENT

The high velocity Uniflux burner has a very short flame extension, preventing flame impingement on the process tubes. This in turn reduces tube failure and coking.

EFFICIENCY

The forced draft burner operates at very low excess air. This feature allows the Uniflux Convection Heater to operate at higher efficiencies than can be achieved with conventional radiant, natural draft heaters. Uniflux Convection Heaters equipped with process pre-heat economizers can achieve efficiencies as high as 95% for some processes, and the forced draft design allows the Uniflux heater to maintain the efficiency over the entire operating range.



TURNDOWN

The normal turndown ratio of the Uniflux Convection Heater is 10:1. Turndown ratios of 40:1 can be achieved with custom designed burner controls.



SAFETY AND RELIABILITY

Each Uniflux Convection Heater is equipped with a field proven burner management system and safety controls. The heater and all of its controls are completely shop assembled. The control system is tested at the factory to ensure safe and reliable operation when installed.



LOWER INSTALLATION COSTS

The Uniflux Convection Heater is designed as a package and is completely assembled at the factory.

Smaller heaters are shipped as a complete package. Larger heaters are disassembled into three major components. This makes installation easy and less costly.

FIELD SERVICE

Qualified, experienced technicians are available to assist the customer with start-up, operator training, preventative maintenance programs and trouble shooting.

APPLICATIONS

Uniflux Convection Heaters are used worldwide in numerous industries for a variety of heating applications. A few are listed below:

- Heat Transfer Fluids
- Cryogenic fluids
- LNG Liquefaction & Vaporization
- Regeneration Gas
- Crude Oil
- Natural Gas Processing
- Glycol-water
- Emulsions
- Offshore Production Processing
- Air & Nitrogen
- Vaporizers
- Specialty Chemical Processes



OTHER PRODUCTS

Exotherm Forced Draft Water Bath Heaters, Q-PAK Direct Fired Air Heaters, and Heat Media Circulation Systems.



TLV

TLV CORPORATION

13901 South Lakes Drive
Charlotte, NC 28273
Phone: 704.597.9070
Fax: 704.583.1610
www.tlv.com

TLV®

Since its debut in 1950 with the first "Trouble-Less Valve", TLV has continued to provide industry leading advancements in steam control technology. Today, TLV is a global company offering a broad range of high performance products which deliver extended service life and improved energy efficiency. Manufacturer TLV CO., LTD. Kakogawa, Japan, is approved to ISO 9001 and ISO 14001 standards.



TLV's PowerDyne® series

GREATER SIMPLICITY = HIGHER RELIABILITY

Buying TLV traps and related products means getting longer service life. Our design philosophy is to reduce the number of moving parts, thereby improving reliability. This principle is demonstrated in both our Free Float® and PowerDyne® traps.

TLV introduced the **Free Float®** concept to the steam industry over 45 years ago. Unlike other designs, there are no levers or linkages. The balanced float itself is the only moving part and can achieve a nearly perfect sphericity, creating an unmatched sealing performance. **PowerDyne®** disc traps include an air vent developed and patented by TLV to enable mirror-finish surfaces. The result is that both series provide exceptional energy efficiency.

TLV Free Float® and PowerDyne® traps are designed for severe service operation. Even at high pressures and temperatures, they provide excellent durability and resistance to water hammer and superheat, ensuring long and reliable operation.



STEAM SYSTEM MANAGEMENT

TLV offers technical assistance, on-site service, and training to help customers optimize the performance of their steam systems. We also offer diagnostic tools you can use to help ensure proper management of the steam trap population. Such system capabilities help maximize productivity, extend reliability, improve energy efficiency, and fulfill safety/environment requirements.

The TrapMan® Steam Trap Management System includes the TM5N portable data collection and measurement unit and Windows®-based TrapManager® software, which is loaded on a personal computer. The TM5N captures both ultrasound and contact temperature measurements from traps at the site. When uploaded to a PC, TrapManager® analyzes the data and makes an automatic judgment of the trap's condition, highlighting steam traps that require attention. TrapManager® provides detailed printed reports including trap logs, histories, and results analysis to effect optimal maintenance budget allocation.



SERVICES

TLV also offers Consulting & Engineering Services. CES engineers, who are certified AEE energy managers and DOE steam system specialists, can provide process recommendations and fully-piped packaged solutions for improving your new or existing steam system. CES services can provide a full steam and condensate balance to enable effective short and mid-term planning.

TLV believes that true customer satisfaction can only be obtained by finding solutions to the various challenges encountered while running businesses and operating steam plants. TLV Consulting & Engineering Services is designed to find the best solutions to increase productivity, maximize energy savings, improve quality and promote environmental conservation. CES activities are the embodiment of a complete customer satisfaction philosophy.

ANIVI

ANIVI INGENIERIA,S.L.
Avad. Chorierrri, 8
48180 Loiu Spain
Tel: +34 94 453 19 00
info@anivi.com
www.anivi.com



OPTIMIZING SOLIDS GRINDING, DRYING OR CALCINATION PROCESSES

For big projects, big engineering companies provide excellent consultancy services. But for small/medium size projects involving certain operations, ANIVI can help technicians from the first decisions up to the machinery start-up and commissioning.

An old sentence states: "Years to take a decision and when it is taken, months to develop it". This is a common situation for many professionals. When it is time to execute after long time of technical and financial studies, hurries start.

Regardless of the project



size, there some basic steps a project must follow to succeed. After decades of experience in the grinding and classification, solids drying and calcination, ANIVI is able to offer advisory services in all of the required steps.

These services may include:

- Process prefeasibility and feasibility
- Laboratory and pilot plant tests
- Project cost evaluation
- Process optimization
- Lay-out studies
- Machine manufacturing
- Erection supervision
- Start-up and commissioning

To offer this, ANIVI has a group of high skilled engineers, together with a laboratory, and a pilot plant with several machines in order to provide process information at a semiindustrial scale, that can be used in the final design of the process plant machines.

The sectors that can be attended include industrial minerals, cement, wall and floor tile manufacturing, mining, chemical, waste treatments, recycling, incineration, energy and others in which the described basic operations are necessary.

Nowadays, it is very important to pay a lot of attention to the environmental factors in all the newcoming projects. In its services ANIVI take much care of it. All ANIVI engineers have strong knowledge of the last regulations and norms, and this basic principle rules all the designs and advices.

Finally, in terms of economy, ANIVI helps the project managers to fulfil the budgets offering the most accurate designs to reach the highest productivity in the shortest time period.

CHEmploy

The Career Catalyst for Chemical Engineers

Post your resume and cover letter at chemengonline.com/chemploy today!

- » Chemploy job center focuses exclusively on jobs in the CPI
- » Receive job alerts directly to your email of any new jobs posted that match your search preferences
- » Access the Careers Resources library which offers you valuable coaching and career guides

Looking for that dream job in the chemical process industries?



Create an account now and never miss a new opportunity!

Don't let the competition score that perfect position you deserve.

If interested in posting a job, please contact:

TERRY DAVIS
 404-634-5123 | tdavis@accessintel.com

JASON BULLOCK
 713-974-0911 | jbullock@chemengonline.com

PRODUCT & SERVICE INDEX

HOW TO USE THIS GUIDE

Using CEBG is simple and straightforward:

1. Look up the product or service under the main noun that describes it in the Product & Service Index; for example, Pumps, rotary, or Analyzers, infrared. Ample cross-referencing is provided for products with several names. Boldface items are general product categories.
2. Turn to the indicated page in the Product & Service Directory, where you will find the names of manufacturers of that product. Companies in boldface and capital letters are display advertisers; page numbers direct you to their product inserts or advertisements.
3. Refer to the Company Directory to find the manufacturers nearest you—your local sources. Call the sources for data, delivery and price. Please be sure to tell them how quickly you found them in CEBG.

A

Acids, amino.....	107	Analyzers, carbon dioxide or monoxide..	77	Baghouses	85
Acids, fatty.....	107	Analyzers, combustible gases	77	Barrel handling equipment.....	73
Acids, organic	107	Analyzers, concentration.....	77	Batch control	102
Actuators	77	Analyzers, conductivity	77	Batching & blending systems	74, 90
Actuators or starters, motor.....	76	Analyzers, corrosion rate.....	77	Bends, pipe.....	66
Actuators, operators.....	77	Analyzers, gas density	77	Bin activators.....	72
Adsorption systems, carbon	105	Analyzers, hydrocarbons	77	Bins.....	72
Advanced process control	102	Analyzers, mass spectrometer.....	77	Bins & other dry storage equipment	72
Aerators	93	Analyzers, offstream.....	77	Bins, weighing.....	72
Afterburners	105	Analyzers, onstream.....	78	Bio-oxidation units.....	106
Aftercoolers	87	Analyzers, organic carbon	77	Biocides, halogenated	107
Agglomerators.....	72	Analyzers, organic carbon, total	77	Biocides, other	107
Air conditioning & refrigeration equipment.....	82	Analyzers, oxygen, dissolved.....	77	Bioreactors	92
Air pollution abatement systems	105	Analyzers, particle size	77	Blenders, cone	90
Air pollution control.....	105	Analyzers, pH.....	77	Blenders, continuous.....	90
Air pollution control equipment & systems	105	Analyzers, spectrometer	77	Blenders, horizontal.....	90
Air preheat systems.....	88	Analyzers, suspended solids	77	Blenders, inline.....	90
Air separation equipment.....	64	Analyzers, total solids.....	77	Blenders, liquid feed	90
Air separation equipment, cryogenic.....	64	Analyzers, vapor pressure	77	Blenders, pneumatic	90
Air separation equipment, membrane.....	64	Analyzers, vibration	98	Blenders, ribbon.....	90
Air separation equipment, pressure swing adsorption	64	Analyzers, water quality	77	Blenders, spiral	91
Air separation equipment, vacuum swing adsorption	64	Anchors, refractory.....	97	Blenders, tumbling V.....	91
Alarm Management.....	102	Antioxidants.....	107	Blowers, centrifugal, compressor-type...	66
Alarms, combustion	79	Arresters, flame deflagration or detonation	98	Blowers, positive displacement.....	66
Alarms, flame	79	Arresters, flame, tank vent, inline	98	Blowers, rotary piston.....	66
Alarms, flow.....	79	Arresters, surge.....	98	Boiler accessories.....	75
Alarms, liquid level	79	Asset management	102	Boiler feedwater systems	95
Alarms, temperature.....	79	Associations	64, 72, 75, 77,	Boilers, automatic, packaged	75
Alcohols, other.....	107	Autoclaves.....	82, 90, 98, 102, 105	Boilers, coal fired.....	75
Analog process control computers	78			Boilers, fire tube	75
				Boilers, fluid bed.....	75
				Boilers, industrial	75
				Boilers, integral furnace	75
				Boilers, natural gas fired	75
				Boilers, oil fired.....	75
				Boilers, waste heat recovery	75
				Boilers, water tube.....	75

B

Bag filling machines.....	73
Bag, empty, handling systems	73

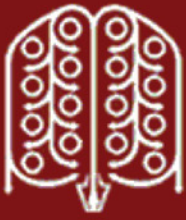

UNIFLUX

Helical Coil Convection Heaters

•Unique forced draft convective heat transfer process heaters

•The UNIFLUX high velocity burner's short flame extension prevents flame impingement on the tubes and eliminates tube coking and fluid degradation.

•UNIFLUX heaters utilize the complete circulation of exhaust gases around the process tubes resulting in uniform flux density around the tube periphery creating long tube life.

•Automatic operating and safety controls meet NFPA, API, NEC or IEC requirements, and utilize FM, CSA, and UL listed control components. UNIFLUX heaters and controls are factory assembled and tested.



APPLICATIONS

- Heat Transfer Fluid
- Regeneration Gas
- Water
- Glycol-water
- Air
- Steam Superheaters
- Cryogenic
- Crude Oil
- Emulsions
- Offshore Production
- Gas Processing
- Natural Gas Liquids
- Vaporizers

SPECIFICATIONS

- 0.5 million to 70 million Btu/Hr
- 40:1 Turndown Capability
- High Efficiency Economizer
- Process Temperatures to 1500 °F
- Carbon Steel, Stainless Steel & High Alloy Heat Transfer Coil Material
- Natural Gas or Light Oil Fuels

www.exotherm.com

Exotherm Corporation • 31369 Nichols Sawmill Rd • Magnolia, TX 77355

Phone: 713-981-9100 • Fax: 713-981-7081 • Toll Free: 866-762-9041 • email: info@exotherm.com

For details visit adlinks.chemengonline.com/80076-21

PRODUCT & SERVICE INDEX

Boosters, rotary piston	66
Brass	96
Bronze	96
Bulk carriers, loading & unloading equipment	72
Burners, gas	89
Burners, oil	89

C

Cable & conduit	75
Calibration & test equipment	80
Calibration gas standards	80
Calorimeters	80
Carbides	96
Carbon & graphite	96
Carbon steels	97
Cast irons	96
Cast irons, alloy	96
Cast irons, high-silicon	96
Castables	97
Catalyst supports & systems	107
Catalysts, custom	107
Catalysts, desulfurization	107
Catalysts, polymerization	107
Centrifuge parts & accessories	82
Centrifuges	82
Centrifuges, batch, automatic basket	82
Centrifuges, batch, perforated basket	82
Centrifuges, continuous, conical angle, perforated basket	82
Centrifuges, continuous, pusher discharge	82
Centrifuges, continuous, solid bowl, scroll discharge	82
Centrifuges, disc, nozzle discharge	82
Centrifuges, disc, solid bowl	82
Centrifuges, disc, valve discharge	82
Centrifuges, filter, continuous, screen bowl, scroll discharge	82
Centrifuges, laboratory or pilot plant	82
Centrifuges, liquid-liquid	83
Centrifuges, solid basket	83
Ceramic metals	96
Ceramics, including glass	96
Chambers, test	80
Chemical equipment design	102
Chemical plant design & maintenance	102
Chemical process design	102
Chillers, recirculating	88
Chromium & alloys	96
Chutes	72
Circuit breakers	76
Classifiers & gravity separators	83
Classifiers, air	83
Classifiers, cyclone	83
Cleaning equipment & services	98
Cleaning equipment, pharmaceutical	98
Cleaning equipment, steam	98
Cleaning equipment, tank cleaning	98
Clothing, chemical resistant	98
Coalescers	92
Coaters & coating machinery	72
Coating, forming & agglomeration equipment	72
Coatings, acrylic	97
Coatings, epoxy	97
Cobalt alloys	96
Cogeneration systems & equipment	76
Coils	88
Coils, tubing	69
Columns, absorption or adsorption	94
Columns, bubble cap	94
Columns, custom fabricated	94
Columns, packed	94
Columns, vacuum	94
Columns, valve tray	94
Combustors, catalytic	105
Combustors, other	105
Comminutors	94
Composites	96
Compressors	64
Compressors, centrifugal	64
Compressors, diaphragm	64
Compressors, high pressure	64
Compressors, oil-free	64
Compressors, portable	64
Compressors, reciprocating	64
Compressors, rotary	64
Compressors, rotary liquid ring	64
Compressors, rotary screw	64
Computer hardware	102
Computer software	102
Computers for design & engineering	103
Computers, monitors & displays	102
Computers, personal	102
Computers, printers & plotters	102
Computers, process control	78
Condensate return systems	87
Condensers, air cooled	87
Condensers, barometric	87
Condensers, coil	87
Condensers, evaporative refrigerant	87
Condensers, jet ejector	87
Condensers, reflux	87
Condensers, shell & tube	87
Condensers, steam	87
Condensers, surface	87
Condensers, tubular	87
Condensers, vapor	87
Consultants, corrosion protection	100
Consultants, engineering	100
Consultants, materials	100
Consultants, safety & health	100
Consultants, water treatment	100
Containers, safety	98
Contract manufacturing systems	100
Controllers	78
Controllers, air conditioning	78
Controllers, batching or weighing	78
Controllers, bin level	78
Controllers, boiler	78
Controllers, combustion	78
Controllers, electric	78
Controllers, flow & flow ratio	78
Controllers, hydraulic	78
Controllers, liquid level	78
Controllers, pH	78
Controllers, pneumatic	78
Controllers, pressure	78
Controllers, process	79
Controllers, programmable	79
Controllers, pump	79
Controllers, sludge level	79
Controllers, temperature	79
Controllers, vacuum	79
Controllers, viscosity	79
Converters, signal	81
Conveyor belting	72
Conveyors & elevators for bulk materials	72
Conveyors, belt	72
Conveyors, bucket	72
Conveyors, drag	73
Conveyors, flexible	73
Conveyors, flight	73
Conveyors, fluidizing	73
Conveyors, gravity	73
Conveyors, other	73
Conveyors, pneumatic	73
Conveyors, portable	73
Conveyors, screw	73
Conveyors, vacuum	73
Conveyors, vibrating	73
Conveyors, weighing	73
Coolers, air cooled	87
Coolers, belt	87
Coolers, closed circuit	87
Coolers, coil	87
Coolers, evaporative	87
Coolers, finned tube	87
Coolers, flash	87
Coolers, screw	87
Coolers, water	87
Cooling tower systems	83
Cooling towers	83
Copper	96
Copper & copper alloys	96
Copper alloys, other	96
Corrosion measurement equipment	80
Couplings, pneumatic conveyors	73
Crushers, impact	94
Crushers, jaw	94
Crushers, rotary	94
Crystallizers, cooling	85
Crystallizers, evaporative	85
Crystallizers, freeze	85
Crystallizers, melt	85
Crystallizers, scraped surface	85
Crystallizers, vacuum	85
Custom fabricated equipment	83
Custom processing	100

D

Dampers	64
Data acquisition & process control	102
Data logging systems	79
Data presentation equipment	79
Data Transmission, Wireless	81

PRODUCT & SERVICE INDEX

Data visualization	102	Dryers, vertical	84	Equipment, used: procurement & supply	101
Database services	100	Dryers, vibrating	84	Evaporative systems, mechanical recompression	85
Deaerators, degasifiers	92	Ductile iron	96	Evaporative systems, multiple effect	85
Decanters	83	Ducts & ventilation systems	64	Evaporative systems, thermal recompression	85
Defoamers, physical	85	Ducts, flexible	64	Evaporators & crystallizers	85
Density-measuring equipment	80	Ducts, metallic	64	Evaporators, agitated film	85
Desalination units	95	Ducts, rigid	64	Evaporators, climbing film	85
Desuperheaters	87	Dumpers	72	Evaporators, falling film	85
Detectors, gases	77	Dust collector parts & accessories	85	Evaporators, flash	85
Detectors, interface	80	Dust collectors & separators	85	Evaporators, forced circulation	85
Detectors, leak	80	Dust collectors, bag filtering	85	Evaporators, horizontal tube	86
Detectors, sludge blanket level	77	Dust collectors, cartridge	85	Evaporators, low temperature	86
Detectors, vibration	78	Dust collectors, cyclone	85	Evaporators, plate type	86
Dewatering, mechanical press	86	Dust collectors, electrostatic precipitators	85	Evaporators, short path	86
Digesters, cookers	92	Dust collectors, other	85	Evaporators, thin film	86
Direct digital process control computers	78	Dust collectors, pulse jet	85	Evaporators, vertical long tube	86
Dispersing agents, leather	107	Dust collectors, wet	85	Evaporators, waste water	86
Dispersing agents, other	107	Dust removal equipment	85	Evaporators, wiped film	86
Dispersing agents, rubber	107			Expanders	76
Distillation columns, automatic packaged unit	94	E		Expansion joints, flexible	66
Distillation columns, molecular distillation	94	Economizers	87	Explosion isolation	98
Distillation columns, sieve tray	94	Elbows, pipe	66	Explosion vents	98
Distillation columns, steam stripping	94	Electrical & power generation equipment	76	Extruders	72
Distillation columns, vapor compression	95	Electrical equipment, intrinsic safety	81		
Drives, gear	75	Electrical equipment, other	76	F	
Drives, other	75	Electrical heating equipment	76	Failure analysis	102
Drives, turbine	75	Electrochemical equipment	85	Fans & blowers	66
Drum filling equipment	73	Electrodes, pH	81	Fans, heavy duty	66
Drum handling equipment	73	Electrodes: anodes & cathodes	85	Felt, filter	86
Dryer parts & accessories	83	Electrolytic cells	85	Fermentation equipment & fermentors	92
Dryers	83	Emergency shutdown systems	98	Filter bags, acidproof	86
Dryers, air	83	Emulsifiers	107	Filter bags, alkaliproof	86
Dryers, batch	83	Engineering services	100	Filter bags, glass	86
Dryers, belt	83	Engineering, biochemical & biotech	100	Filter bags, natural fiber	86
Dryers, centrifugal	83	Engineering: construction & field erection	100	Filter bags, synthetic fiber	86
Dryers, closed circuit	83	Engineering: cryogenic equipment	100	Filter housings	86
Dryers, conical, vacuum	83	Engineering: facilities planning	100	Filter media & aids	86
Dryers, continuous	83	Engineering: instrumentation & control systems	100	Filter media, other	86
Dryers, conveyor	83	Engineering: modular process systems	100	Filter parts & accessories	86
Dryers, drum	83	Engineering: packaged pilot plants	100	Filter presses	86
Dryers, drum, rotary vacuum	83	Engineering: pilot plants	100	Filter systems	86
Dryers, electric	83	Engineering: plant design	100	Filters, activated carbon	86
Dryers, flash	83	Engineering: plant modernization	100	Filters, air	86
Dryers, fluidized bed	83	Engineering: pollution & environmental services	101	Filters, bag	86
Dryers, freeze	83	Engineering: process design	101	Filters, belt	86
Dryers, gas	83	Engineering: process modeling	101	Filters, bio-oxidation	106
Dryers, paddle	83	Engineering: procurement	101	Filters, cartridge	86
Dryers, pan	84	Engineering: project management	101	Filters, crossflow	86
Dryers, ring	84	Engineering: research	101	Filters, disc, pressure	86
Dryers, rotary	84	Entrainment separation equipment	85	Filters, disc, vacuum	86
Dryers, screw flight	84	Environmental consulting	105	Filters, drum, rotary pressure continuous	86
Dryers, shelf, vacuum	84	Environmental services	105	Filters, gas	86
Dryers, spiral screw	84	Equipment repair & rebuilding	98	Filters, horizontal belt, vacuum	86
Dryers, spray	84	Equipment testing	101	Filters, leaf, horizontal, pressure	86
Dryers, steam jacketed	84	Equipment, process, custom	83	Filters, leaf, vacuum	86
Dryers, steam tube	84	Equipment, process, custom, cryogenic	83	Filters, leaf, vertical, pressure	86
Dryers, tray	84			Filters, membrane	86
Dryers, tray, vacuum	84			Filters, microfiltration	86
Dryers, tumble	84				
Dryers, tunnel	84				
Dryers, V cone	84				
Dryers, vacuum	84				

PRODUCT & SERVICE INDEX

Filters, nanofiltration	86
Filters, nutsche	86
Filters, oil removal	86
Filters, pan	86
Filters, pipeline	86
Filters, plate & frame	86
Filters, porous metal	86
Filters, portable	86
Filters, sand	86
Filters, ultrafiltration	87
Filters, water	87
Filtration equipment	86
Flame retardants	107
Flanges	66
Flares, stack & accessories	105
Flexible hose, metallic & nonmetallic	66
Flowmeters, differential pressure	79
Flowmeters, electromagnetic	79
Flowmeters, magnetic	79
Flowmeters, mass	79
Flowmeters, positive displacement	79
Flowmeters, rotameters	79
Flowmeters, turbine	79
Flowmeters, ultrasonic	79
Flowmeters, variable area	80
Flowmeters, vortex shedding	80
Fluorocarbons	97
Furnaces, gas burning	89
Furnaces, high pressure	89
Furnaces, high temperature	89
Furnaces, vertical	89
Fused silica	96

G

Gages, liquid level	80
Gages, pressure	80
Gages, tank	80
Gages, vacuum & differential pressure	80
Gages, water	80
Gaskets, fluoroplastic	68
Gaskets, rubber	68
Gates, hopper	72
Generator-turbine sets	76
Generators, carbon dioxide	92
Generators, electrical	76
Generators, hydrogen	92
Generators, nitrogen	92
Generators, steam	88
Glasses, sight flow	80
Gold & alloys	96
Granulators & granulating mills	72
Groundwater remediation	105

H

Heat exchanger parts & accessories	87
Heat exchangers, air cooled	87
Heat exchangers, all-welded	87
Heat exchangers, cascade	87
Heat exchangers, coil	87
Heat exchangers, condensers & coolers	87
Heat exchangers, direct contact steam	87

Heat exchangers, double pipe	87
Heat exchangers, finned tube	87
Heat exchangers, plate	87
Heat exchangers, plate fin	87
Heat exchangers, PTFE tube	87
Heat exchangers, scraped surface	87
Heat exchangers, screw flight	87
Heat exchangers, shell & tube	87
Heat exchangers, spiral	88
Heat exchangers, titanium	88
Heat exchangers, U tube	88
Heat exchangers, zirconium	88
Heat transfer fluids, cooling fluids	88
Heat transfer fluids, heating fluids	88
Heat transfer fluids, other	88
Heat transfer media	88
Heat transfer systems	88
Heat-exchange modeling	102
Heaters, air & gas	88
Heaters, direct fired	88
Heaters, drum	88
Heaters, electric immersion	76
Heaters, feedwater	88
Heaters, finned tube	88
Heaters, gas fired	88
Heaters, helical coil	88
Heaters, immersion	88
Heaters, indirect fired (waterbath)	88
Heaters, instantaneous	88
Heaters, jacketed	88
Heaters, molten salt	88
Heaters, pipeline	88
Heaters, portable	88
Heaters, process liquid	88
Heaters, process slurry	88
Heaters, steam injection	88
Heaters, tank car	88
Heaters, thermal fluid electric	76
Heaters, thermal liquid	88
Heaters, tubular	88
Heating & cooling equipment, other	88
High alloy steels	97
Hoists	73
Homogenizers	89
Homogenizers, high pressure	89
Hoods, fume collectors	64
Hoppers	72
Hoppers, weighing	72
Hose, chemically resistant	66
Hose, metallic	66
Hose, nonmetallic, fluoroplastic	66
Hot oils	88
Hybrid process control computers	78
Hydrogen	107
Hydrogen sulfide removal systems	105
Hydrogenation reactors	92
Hypochlorinators	95

I

Incinerators	106
Incinerators, gas & liquid	106
Indicators	79

Indicators, bin level	80
Indicators, flow	80
Indicators, liquid level	80
Indicators, mass flow	80
Indicators, solids level	80
Indicators, specific gravity	80
Indicators, temperature	80
Indicators, viscosity	80
Indicators, weight	80
Indium & alloys	96
Indoor-air-quality services	105
Information management	102
Information technology	102
Inhibitors, corrosion	107
Input & output equipment, data processing	102
Input-output equipment	78
Inserts, heat-exchanger tube	88
Inspection	101
Insulation materials	96
Insulation, high temperature	96
Iron & iron alloys	96

K

Kettles, agitated	92
Kettles, crystallizing	92
Kettles, electrically heated	92
Kettles, jacketed	92
Kettles, melting	92
Kettles, special metals	92
Kettles, vacuum	92
Kilns, ovens & furnaces	89
Kilns, rotary	89

L

Laboratory information management	102
Lead & alloys	96
Leak sealing service	98
Lifting equipment	73
Lighting fixtures	76
Lighting, explosion proof	76
Liquid-liquid processing	83
Liquid-mixer parts & accessories	89
Loading arms	72
Low alloy steels	97
Lubricants	96
Lubricants, engine oil	96
Lubricants, greases	96
Lubricants, industrial oils	96
Lubricants, process oils	96
Lumpbreakers	94
Lumpbreakers for solid & liquid systems	94

M

Maintenance tools & equipment & replacement parts	98
Manometers	81
Manufacturing execution systems	102
Materials handling systems	73
Mathematics & statistics	102

PRODUCT & SERVICE INDEX

Measurement & testing equipment	80
Mechanical integrity	102
Medium alloy steels	97
Membrane systems for liquids	93
Metals & alloys, other nonferrous	96
Meters, air	81
Meters, displacement	81
Meters, gas	81
Meters, heat flow	81
Meters, oxygen	81
Meters, pH	81
Meters, ultrasonic	81
Meters, water	81
Microfiltration equipment	87
Microscopes	81
Mills, attrition	94
Mills, ball	94
Mills, cage	94
Mills, colloid	94
Mills, cone	94
Mills, disc	94
Mills, grinding	94
Mills, hammer	94
Mills, homogenizing	94
Mills, impact	94
Mills, jacketed ball	94
Mills, other	94
Mills, rod	94
Mills, roller	94
Mills, vertical	94
Mist eliminators	85
Mixers, air driven	89
Mixers, anchor	89
Mixers, batch	89
Mixers, bottom entering	89
Mixers, chilled	89
Mixers, cone	89
Mixers, continuous	89
Mixers, continuous kneaders	91
Mixers, disc	89
Mixers, double arm kneaders	91
Mixers, gas-liquid, high intensity	89
Mixers, gate	89
Mixers, gravity flow	91
Mixers, heated	89
Mixers, high shear	91
Mixers, high viscosity	89
Mixers, jet	89
Mixers, magnetically coupled	91
Mixers, motionless	91
Mixers, other solid-liquid	91
Mixers, paddle	89
Mixers, pan	91
Mixers, pipeline (inline)	90
Mixers, planetary	91
Mixers, pony	90
Mixers, portable	90
Mixers, pressure	90
Mixers, propeller	90
Mixers, ribbon	91
Mixers, roller	91
Mixers, rotary blade	91
Mixers, rotary disc	91

Mixers, rotary drum	91
Mixers, screw	91
Mixers, sealless	91
Mixers, side entering	90
Mixers, slurry	90
Mixers, spiral ribbon	91
Mixers, spiral screw	91
Mixers, static	90
Mixers, top entering	90
Mixers, turbine	90
Mixers, vacuum	90
Mixers, vacuum tumble	91
Mixers, vertical stationary	91
Mixers: barrel, drum, carboy	90
Mixing equipment for fluids	89
Mixing equipment for gas, air	90
Mixing equipment for solids & fluids	90
Molybdenum & alloys	97
Monitors, air quality	78
Monitors, combustible gases, or vapors	78
Monitors, conductivity	78
Monitors, dust	78
Monitors, emissions, continuous	78
Monitors, hydrocarbon content	78
Monitors, opacity	78
Monitors, oxygen content	78
Monitors, particle size	78
Monitors, stack gases	78
Monitors, viscosity	78
Monitors, water quality	78
Monomer-recovery systems	93
Motor controls	76
Motors, electric	76
Motors, explosion proof	76
Motors, variable speed	76
Mullers	91

N

Nickel	97
Nickel & nickel alloys	97
Nickel alloys	97
Niobium	97
Noise & vibration suppression equipment	98
NOx control systems	105
Nozzles, mixing	93
Nozzles, spray	93
Nylon	97

O

Odor-control systems	105
Organic intermediates	107
Other electrical equipment	76
Ovens, drying	89
Ovens, electric	89
Ovens, vacuum	89
Oxidizers, catalytic	106
Oxidizers, thermal	106

P

Packaging equipment	73
Packaging equipment, solids	73
Packers, bag	73
Packings, plastic	68
Packings, random	68
Packings, ring	68
Packings, tower & column, ceramic	92
Packings, tower & column, metal	92
Packings, tower & column, plastic	92
Packings, tower & column, random	92
Packings, tower & column, structured	92
Packings, trays for towers & columns	92
Palladium & alloys	97
Palletizers	73
Paper, filter	86
Particle size control systems	83
Particulate removal systems	105
Pervaporation equipment	93
Physical properties	102
Pigments	107
Pilot plant services	101
Pipe fitting, stainless steel	66
Pipe fittings & couplings, metallic & nonmetallic	66
Pipe fittings, high pressure	66
Pipe fittings, nonmetallic	66
Pipe, alloy steel	66
Pipe, containment	66
Pipe, copper & copper alloys	66
Pipe, copper alloy	66
Pipe, nickel & nickel alloy	66
Pipe, nonmetallic	66
Pipe, other	66
Pipe, plastic	66
Pipe, PTFE	66
Pipe, rubber	66
Pipe, stainless steel	66
Pipe, stainless steel, duplex	66
Pipeline rehabilitation processes	98
Plant documentation services	101
Plant maintenance services	98
Plant optimization	102
Plastics materials	97
Plastics, other	97
Plates, filter	86
Platinum & alloys	97
Polyesters	97
Polyethylenes	97
Polymerizers	92
Polypropylenes	97
Powders, ceramic	96
Preheaters	88
Preservatives	107
Process control	103
Process optimization	103
Process safety management	103
Process safety management services	101
Process simulation	103
Process simulation systems	103
Process vessels & reactors	92
Production scheduling	103

PRODUCT & SERVICE INDEX

Proportioners.....	74	Pumps, vertical & deep well.....	68	Scales, railroad car.....	74
Protective coatings & linings.....	97	Pumps, vertical centrifugal.....	68	Scales, tank.....	74
Pump parts & fittings.....	66	Pumps, water.....	67	Scales, totalizing.....	74
Pump repair.....	98	Pyrometers.....	81	Scales, truck.....	74
Pumps parts & accessories.....	66			Screening.....	93
Pumps, acid, corrosive.....	66	R		Screening equipment.....	93
Pumps, air driven.....	66			Screens, perforated plate.....	93
Pumps, axial flow.....	66	Radio remote control systems.....	81	Screens, vibrating.....	93
Pumps, battery-powered.....	66	Reaction & separation equipment, other.....	93	Screw presses.....	87
Pumps, canned motor.....	66	Reactors, continuous.....	92	Scrubbers.....	93
Pumps, carboy or drum.....	66	Reactors, cooled, heated.....	92	Scrubbers, cyclone.....	93
Pumps, centrifugal.....	66	Reactors, fluid bed.....	93	Scrubbers, fluidized bed.....	93
Pumps, centrifugal, ANSI.....	66	Reactors, gas-liquid.....	93	Scrubbers, fume, gas.....	93
Pumps, centrifugal, dry running.....	66	Reactors, jacketed.....	93	Scrubbers, impingement baffle.....	94
Pumps, centrifugal, multistage.....	66	Reactors, jacketed, dimple.....	93	Scrubbers, jet.....	94
Pumps, centrifugal, process, medium duty.....	66	Reactors, jacketed, half-pipe.....	93	Scrubbers, oil mist.....	94
Pumps, centrifugal, self-priming.....	66	Reactors, lined, glass.....	93	Scrubbers, orifice.....	94
Pumps, centrifugal, single stage.....	66	Reactors, lined, metal.....	93	Scrubbers, packed column.....	94
Pumps, ceramic.....	68	Reactors, loop.....	93	Scrubbers, spray.....	94
Pumps, condensate return.....	66	Reactors, pilot plant.....	93	Scrubbers, venturi.....	94
Pumps, diaphragm (proportioning).....	67	Reactors, rotary blade.....	93	Seals, balanced pressure.....	68
Pumps, diaphragm (reciprocating).....	68	Reboilers.....	88	Seals, bearing.....	68
Pumps, dry vacuum.....	66	Recroders.....	81	Seals, gaskets & packing materials.....	68
Pumps, explosion proof.....	66	Recorders, mass flow.....	81	Seals, magnetic.....	69
Pumps, gear.....	68	Refractories.....	97	Seals, mechanical.....	69
Pumps, hand.....	67	Refractory materials.....	97	Separators.....	93
Pumps, high pressure.....	67	Refractory mortars & cements.....	97	Separators, fluidizing.....	93
Pumps, jacketed.....	67	Refrigeration equipment & systems.....	82	Separators, magnetic.....	93
Pumps, leakproof.....	66	Refrigeration equipment, chillers.....	82	Separators, oil-water.....	106
Pumps, lobe.....	68	Refrigeration equipment, freezers.....	82	Showers, emergency.....	98
Pumps, magnetically driven.....	67	Regulators, air.....	79	Silencers, exhaust.....	98
Pumps, metering.....	67	Regulators, back pressure.....	79	Silencers, inline.....	98
Pumps, nonmetallic.....	68	Regulators, flow.....	79	Silencers, intake.....	98
Pumps, oil free.....	67	Regulators, pressure.....	79	Silicon carbide.....	96
Pumps, open impeller.....	67	Regulators, temperature.....	79	Silos.....	72
Pumps, other.....	66, 67	Regulators, vacuum.....	79	Silver & alloys.....	97
Pumps, other special materials.....	68	Regulatory compliance.....	103	Simulators.....	102
Pumps, peristaltic.....	67	Relays, time delay.....	81	Sinks, eye or face emergency.....	98
Pumps, piston.....	68	Resins, ion exchange.....	95	Size reduction equipment.....	94
Pumps, piston-diaphragm.....	68	Resins, water-soluble.....	107	Sludge dewaterers.....	106
Pumps, plastic.....	68	Reverse osmosis systems.....	95	Sludge dryers.....	106
Pumps, pressure powered.....	67	Risk analysis.....	101	Sludge handling.....	105
Pumps, progressing cavity.....	68	Roasters, food products.....	89	Software development.....	103
Pumps, proportioning.....	67	Robotic components.....	73	Software, other.....	103
Pumps, reciprocating.....	68	Rotary Lobe Pumps.....	68	Soil remediation.....	105
Pumps, rotary.....	68	Rubber & rubberlike materials.....	97	Solid-liquid-mixer parts & accessories.....	91
Pumps, rotary liquid ring.....	68	Rubber, urethane.....	97	Solids feeders, airlock.....	73
Pumps, rotary positive displacement.....	68	Rupture discs.....	98	Solids feeders, batch.....	73
Pumps, sealless.....	67			Solids feeders, continuous flow.....	73
Pumps, sludge.....	67	S		Solids feeders, gravimetric.....	73
Pumps, slurry.....	67			Solids feeders, proportioning.....	73
Pumps, special materials.....	68	Saddles, polyethylene, tower packings.....	92	Solids feeders, rotary.....	73
Pumps, stainless steel.....	68	Safety equipment & systems.....	98	Solids feeders, vibrating or oscillating.....	73
Pumps, submersible.....	68	Samplers, automatic.....	78	Solids feeders, volumetric.....	73
Pumps, sump.....	68	Samplers, gas, air.....	78	Solids handling equipment & systems, other.....	73
Pumps, transfer.....	67	Samplers, liquid.....	78	Solvent recovery systems.....	93
Pumps, vacuum & ejector.....	68	Scales, checkweight.....	74	Solvents, oxygenated.....	107
Pumps, vacuum, dry.....	68	Scales, continuous weighing.....	74	Spectrometers.....	78
Pumps, vacuum, liquid ring.....	68	Scales, conveying.....	74	Steam jet ejectors.....	68
Pumps, vacuum, once-through-oil.....	68	Scales, counting.....	74	Steam traps.....	69
Pumps, vacuum, other.....	68	Scales, floor, platform.....	74	Steam traps, disc.....	69
Pumps, vacuum, rotary piston.....	68	Scales, hopper.....	74	Steam traps, float.....	69
		Scales, portable.....	74		

PRODUCT & SERVICE INDEX

Steam traps, float & thermostatic	69
Steam traps, inverted bucket	69
Steam traps, thermostatic	69
Steels.....	97
Storage cabinets	98
Storage systems.....	73
Sulfur Recovery	105
Supercritical fluid extraction processing.....	93
Superheaters	88
Supervisory process control computers	78
Surface active agents, not further specified.....	108
Switchgear & other power distribution equipment.....	76

T

Tachometers.....	81
Tank fittings & accessories.....	69
Tanks & other liquid storage vessels.....	69
Tanks, carbon steel	69
Tanks, cryogenic	69
Tanks, cryogenic, vacuum jacketed.....	69
Tanks, custom fabricated	69
Tanks, dimple jacketed.....	69
Tanks, heated	69
Tanks, mixing.....	69
Tanks, pressurized storage	69
Tanks, settling.....	106
Tanks, stainless steel.....	69
Tanks, stainless steel, lined.....	69
Tanks, tapered wall.....	69
Tantalum & alloys.....	97
Technology licensing.....	101
Testing equipment, high pressure.....	98
Testing equipment, other.....	81
Testing instruments, vibration.....	98
Thermal fluids.....	88
Thermometers, infrared.....	80
Thermostats.....	80
Thickeners, centrifugal.....	83
Thickeners, gravity	83
Thickeners, rake or sedimentation	83
Tin & alloys	97
Titanium & alloys	97
Tools & equipment, other.....	98
Tools, hand	98
Tower parts & accessories	95
Towers & columns	94
Training.....	101
Training personnel, maintenance	101
Training personnel, safety & health	101
Training systems, plant operators	101
Transformers.....	76
Transformers, isolation	76
Transmitters & data transmission equipment.....	81
Transmitters, level.....	81
Transmitters, mass flow	81
Transmitters, pressure	81
Transmitters, pressure-critical	81

Transmitters, temperature.....	81
Traps, air.....	85
Trays & tower internals	92
Troughs, cooled or heated	88
Tube fittings	69
Tubing & tube fittings, metallic & nonmetallic.....	69
Tubing, condenser	69
Tubing, evaporator	69
Tubing, finned.....	69
Tubing, heat exchanger	69
Tubing, high pressure.....	69
Tubing, high temperature	69
Tungsten & alloys	97
Turbines, combined steam-gas.....	75
Turbines, mechanical drive, gas	75
Turbines, mechanical drive, steam.....	76

U

Unions, pipe	66
Unloaders, bulk bag.....	72
Unloaders, other.....	72
Unloaders, tank car.....	72
Unloaders, tank truck	72

V

Vacuum pumping systems.....	68
Valve operators, electrohydraulic.....	77
Valve operators, electropneumatic.....	77
Valve operators, piston.....	77
Valve operators, pneumatic.....	77
Valve positioners, microprocessor equipped.....	77
Valve, position indicators.....	77
Valves	69
Valves, air	69
Valves, angle	69
Valves, ball	69
Valves, bellows sealed	69
Valves, butterfly	70
Valves, check	70
Valves, control, electric	70
Valves, control, hydraulic	70
Valves, control, pneumatic	70
Valves, control, regulator.....	70
Valves, control, solenoid.....	70
Valves, cryogenic	70
Valves, diaphragm.....	70
Valves, diverter	70
Valves, diverter conveyor	73
Valves, double block & bleed.....	70
Valves, flush-bottom tank	70
Valves, gate	70
Valves, globe.....	70
Valves, high pressure	70
Valves, high temperature.....	70
Valves, jacketed	70
Valves, knife-gate	70
Valves, metal seated	70

Valves, motor operated	70
Valves, multiport	70
Valves, needle	70
Valves, nuclear	70
Valves, other	70
Valves, packless.....	70
Valves, pilot operated.....	70
Valves, pinch	70
Valves, plastic.....	70
Valves, plastic lined.....	70
Valves, plug	70
Valves, pneumatic	70
Valves, powder	74
Valves, pressure reducing.....	70
Valves, pump protection.....	71
Valves, quick closing.....	71
Valves, relief	71
Valves, safety.....	71
Valves, sampling	71
Valves, tank venting.....	71
Valves, titanium.....	71
Valves, vacuum	71
Valves, vacuum relief.....	71
Valves, vent, low pressure	71
Valves, zirconium.....	71
Vapor recovery systems	105
Vaporizers.....	88
Ventilation systems	64
Vessels, plastic lined	93
Vessels, pressure, cryogenic	93
Vessels, pressure, custom	93
Vessels, pressure, jacketed, dimple.....	93
Vessels, pressure, multilayered heavy wall.....	93
Vessels, pressure, safety sight glass	93
Viscosity or consistency instruments, other	81

W

Waste handling equipment & systems ..	106
Waste heat recovery units	88
Waste-recovery treating systems	106
Water pollution control equipment & systems	106
Water pollution systems	95
Water treatment chemicals.....	108
Water treatment control equipment.....	95
Water-conditioning package systems	95
Weighing, feeding & proportioning equipment	74
Wire & cable	75
Wire mesh.....	93

Z

Zeolites	108
Zinc & alloys	97
Zirconium.....	97

1

LIQUID, GAS, AND AIR HANDLING

- 64 Associations
- 64 Air separation equipment
- 64 Compressors
- 64 Ducts & ventilation systems
- 66 Fans & blowers
- 66 Flexible hose, metallic & nonmetallic
- 66 Pipe fittings & couplings, metallic & nonmetallic
- 66 Pipe, alloy steel
- 66 Pipe, copper & copper alloys
- 66 Pipe, nonmetallic
- 66 Pipe, other
- 66 Pipe, plastic
- 66 Pump parts & fittings
- 66 Pumps, centrifugal
- 66 Pumps, other
- 67 Pumps, proportioning
- 68 Pumps, reciprocating
- 68 Pumps, rotary
- 68 Pumps, special materials
- 68 Pumps, vacuum & ejector
- 68 Pumps, vertical & deep well
- 68 Seals, gaskets & packing materials
- 69 Steam traps
- 69 Tanks & other liquid storage vessels
- 69 Tubing & tube fittings, metallic & nonmetallic
- 69 Valves

ASSOCIATIONS

DECHEMA E.V., Theodor-Heuss-Allee 25, Frankfurt am Main, Germany 60486 (49-69-75-64-0; FAX: 49-69-75-64-201; www.dechema.de)
 — See our ad on page 22

AIR SEPARATION EQUIPMENT

Air separation equipment, cryogenic

CAST-X Circulation Heaters, Batavia, IL
 Shijiazhuang Langrong Chemical Co., Ltd, Shijiazhuang, China

Air separation equipment, membrane

CAST-X Circulation Heaters, Batavia, IL

Air separation equipment, pressure swing adsorption

CAST-X Circulation Heaters, Batavia, IL

Air separation equipment, vacuum swing adsorption

CAST-X Circulation Heaters, Batavia, IL

COMPRESSORS

Compressors, centrifugal

EDWARDS US HEADQUARTERS, Sanborn, NY

Compressors, diaphragm

Fluitron, Inc., Ivyland, PA
 Gas & Air Systems, Inc., Hellertown, PA
 KNF NEUBERGER, INC., 2 Black Forest Rd., Trenton, NJ 08691-1810 (609-890-8600; knfusa@knf.com); www.knfusa.com)

Compressors, high pressure

Fluitron, Inc., Ivyland, PA
 Gas & Air Systems, Inc., Hellertown, PA

Compressors, oil-free

BUSCH VACUUM SOLUTIONS, 516 Viking Dr., Virginia Beach, VA 23452 (800-872-7867; FAX: 757-463-7407; www.buschvacuum.com)

EDWARDS US HEADQUARTERS, Sanborn, NY
 Gas & Air Systems, Inc., Hellertown, PA

KAESER COMPRESSORS, INC., PO Box 946, Fredricksburg, VA 22404 (800-981-6888; FAX: 540-898-5520; info.usa@kaeser.com; us.kaeser.com/chemeng)

KNF NEUBERGER, INC., 2 Black Forest Rd., Trenton, NJ 08691-1810 (609-890-8600; knfusa@knf.com); www.knfusa.com)

Roots Systems, Inc., Monroe, NC

Compressors, portable

KNF NEUBERGER, INC., 2 Black Forest Rd., Trenton, NJ 08691-1810 (609-890-8600; knfusa@knf.com); www.knfusa.com)

Compressors, reciprocating

Gas & Air Systems, Inc., Hellertown, PA
 GEA GROUP, 9165 Rumsey Road, Columbia, MD 21045 (800-722-6622; www.gea.com)
 — See our ad on page 23

KNF NEUBERGER, INC., 2 Black Forest Rd., Trenton, NJ 08691-1810 (609-890-8600; knfusa@knf.com); www.knfusa.com)

Compressors, rotary

BUSCH VACUUM SOLUTIONS, 516 Viking Dr., Virginia Beach, VA 23452 (800-872-7867; FAX: 757-463-7407; www.buschvacuum.com)

EDWARDS US HEADQUARTERS, Sanborn, NY
 Gas & Air Systems, Inc., Hellertown, PA

KAESER COMPRESSORS, INC., PO Box 946, Fredricksburg, VA 22404 (800-981-6888; FAX: 540-898-5520; info.usa@kaeser.com; us.kaeser.com/chemeng)

Roots Systems, Inc., Monroe, NC

Compressors, rotary liquid ring

BUSCH VACUUM SOLUTIONS, 516 Viking Dr., Virginia Beach, VA 23452 (800-872-7867; FAX: 757-463-7407; www.buschvacuum.com)

EDWARDS US HEADQUARTERS, Sanborn, NY

POMPETRAVAINI SPA, via per turbigo 44, Castano Primo, Italy 20022 (+39 0331 889 000; FAX: +39 0331 889 057)

— See our ad on page 47

Compressors, rotary screw

EDWARDS US HEADQUARTERS, Sanborn, NY
 GEA GROUP, 9165 Rumsey Road, Columbia, MD 21045 (800-722-6622; www.gea.com)

— See our ad on page 23

KAESER COMPRESSORS, INC., PO Box 946, Fredricksburg, VA 22404 (800-981-6888; FAX: 540-898-5520; info.usa@kaeser.com; us.kaeser.com/chemeng)

DUCTS & VENTILATION SYSTEMS

Dampers

ACS Industries Inc., Lincoln, RI
 Nordfab Ducting, Thomasville, NC

Ducts, flexible

Nordfab Ducting, Thomasville, NC

Ducts, metallic

Nordfab Ducting, Thomasville, NC

Ducts, rigid

Nordfab Ducting, Thomasville, NC

Hoods, fume collectors

HEMCO Corporation, Independence, Missouri
 Nordfab Ducting, Thomasville, NC

Ventilation systems

HEMCO Corporation, Independence, Missouri

Saving You Money Every Step of the Way



PowerDyne®

Pure Performance Thermodynamic Disc Traps

TLV CORPORATION

13901 South Lakes Drive, Charlotte, NC 28273-6790
Phone: 704-597-9070 Fax: 704-583-1610
E-mail: TLV@TLVengineering.com
For Technical Service 1-800-TLV-TRAP
<http://www.tlv.com>



For details visit adlinks.chemengonline.com/80076-20

Manufacturer

TLV® CO., LTD.

Kakogawa, Japan

is approved by LRQA Ltd. to ISO 9001/14001

ISO 9001/ISO 14001



FANS & BLOWERS

Blowers, centrifugal, compressor-type

INDECK POWER EQUIPMENT CO., 1111 Willis Ave. (CE), Wheeling, IL 60090 (847-541-8300; FAX: 847-541-9984; www.indeck.com)
—See our ad on page 15

KAESER COMPRESSORS, INC., PO Box 946, Fredericksburg, VA 22404 (800-981-6888; FAX: 540-898-5520; info.usa@kaeser.com; us.kaeser.com/chemeng)

Blowers, positive displacement

KAESER COMPRESSORS, INC., PO Box 946, Fredericksburg, VA 22404 (800-981-6888; FAX: 540-898-5520; info.usa@kaeser.com; us.kaeser.com/chemeng)

POMPETRAVINI SPA, via per turbigo 44, Castano Primo, Italy 20022 (+39 0331 889 000; FAX: +39 0331 889 057)
—See our ad on page 47

Roots Systems, Inc., Monroe, NC
Tuthill Vacuum & Blower Systems, Springfield, MO

Blowers, rotary piston

Roots Systems, Inc., Monroe, NC
Tuthill Vacuum & Blower Systems, Springfield, MO

Boosters, rotary piston

Roots Systems, Inc., Monroe, NC
Tuthill Vacuum & Blower Systems, Springfield, MO

Fans, heavy duty

INDECK POWER EQUIPMENT CO., 1111 Willis Ave. (CE), Wheeling, IL 60090 (847-541-8300; FAX: 847-541-9984; www.indeck.com)
—See our ad on page 15

FLEXIBLE HOSE, METALLIC & NONMETALLIC

Hose, chemically resistant

Ametek Fluoropolymer Products, Nesquehoning, PA

Hose, metallic

PROCO PRODUCTS, INC., 2431 N. Wigwam Dr., Stockton, CA 95205 (209-943-6088; FAX: 209-943-0242; www.procoproducts.com)

SWAGELOK CO., 29500 Solon Road, Solon, OH 44139-2764 (440-248-4600; www.swagelok.com)

Hose, nonmetallic, fluoroplastic

PROCO PRODUCTS, INC., 2431 N. Wigwam Dr., Stockton, CA 95205 (209-943-6088; FAX: 209-943-0242; www.procoproducts.com)

PIPE FITTINGS & COUPLINGS, METALLIC & NONMETALLIC

Bends, pipe

BUTTING Group, Knesebeck, Germany

Elbows, pipe

FLUID LINE PRODUCTS INC., 38273 Western Pkwy., P.O. Box 1000, Willoughby, OH 44096 (440-946-9470; FAX: 440-946-9472; www.fluidline.com)

Expansion joints, flexible

PROCO PRODUCTS, INC., 2431 N. Wigwam Dr., Stockton, CA 95205 (209-943-6088; FAX: 209-943-0242; www.procoproducts.com)

Flanges

FLUID LINE PRODUCTS INC., 38273 Western Pkwy., P.O. Box 1000, Willoughby, OH 44096 (440-946-9470; FAX: 440-946-9472; www.fluidline.com)

Pipe Fitting, Stainless Steel

Tylok Fittings & Valves, Cleveland, OH

Pipe fittings, high pressure

Tylok Fittings & Valves, Cleveland, OH

Pipe fittings, nonmetallic

PROCO PRODUCTS, INC., 2431 N. Wigwam Dr., Stockton, CA 95205 (209-943-6088; FAX: 209-943-0242; www.procoproducts.com)

Unions, pipe

Tylok Fittings & Valves, Cleveland, OH

PIPE, ALLOY STEEL

Pipe, nickel & nickel alloy

BUTTING Group, Knesebeck, Germany

Pipe, stainless steel

BUTTING Group, Knesebeck, Germany

Pipe, stainless steel, duplex

BUTTING Group, Knesebeck, Germany

PIPE, COPPER & COPPER ALLOYS

Pipe, copper alloy

BUTTING Group, Knesebeck, Germany

PIPE, NONMETALLIC

Pipe, rubber

PROCO PRODUCTS, INC., 2431 N. Wigwam Dr., Stockton, CA 95205 (209-943-6088; FAX: 209-943-0242; www.procoproducts.com)

PIPE, OTHER

Pipe, containment

Ametek Fluoropolymer Products, Nesquehoning, PA

PIPE, PLASTIC

Pipe, PTFE

PROCO PRODUCTS, INC., 2431 N. Wigwam Dr., Stockton, CA 95205 (209-943-6088; FAX: 209-943-0242; www.procoproducts.com)

PUMP PARTS & FITTINGS

Pumps parts & accessories

ACCA Pumps, Katy, TX

PUMPS, CENTRIFUGAL

Pumps, centrifugal, ANSI

ACCA Pumps, Katy, TX
GEA GROUP, 9165 Rumsey Road, Columbia, MD 21045 (800-722-6622; www.gea.com)
—See our ad on page 23

Hermetic-Pumpen GmbH, Gundelfingen, Germany

Pumps, centrifugal, dry running

Bungartz GmbH & Co. KG, Paul, Duesseldorf, Germany

Pumps, centrifugal, multistage

Dickow Pump Co., Marietta, GA
GEA GROUP, 9165 Rumsey Road, Columbia, MD 21045 (800-722-6622; www.gea.com)
—See our ad on page 23

POMPETRAVINI SPA, via per turbigo 44, Castano Primo, Italy 20022 (+39 0331 889 000; FAX: +39 0331 889 057)
—See our ad on page 47

Pumps, centrifugal, process, medium duty

GEA GROUP, 9165 Rumsey Road, Columbia, MD 21045 (800-722-6622; www.gea.com)
—See our ad on page 23

GORMAN-RUPP PUMPS, P.O. Box 1217, Mansfield, OH 44901-1217 (419-755-1011; FAX: 419-755-1251; g-sales@gormanrump.com; www.grpumps.com)

Pumps, centrifugal, self-priming

Dickow Pump Co., Marietta, GA
GEA GROUP, 9165 Rumsey Road, Columbia, MD 21045 (800-722-6622; www.gea.com)
—See our ad on page 23

GORMAN-RUPP PUMPS, P.O. Box 1217, Mansfield, OH 44901-1217 (419-755-1011; FAX: 419-755-1251; g-sales@gormanrump.com; www.grpumps.com)

Hermetic-Pumpen GmbH, Gundelfingen, Germany
POMPETRAVINI SPA, via per turbigo 44, Castano Primo, Italy 20022 (+39 0331 889 000; FAX: +39 0331 889 057)
—See our ad on page 47

Pumps, centrifugal, single stage

Bungartz GmbH & Co. KG, Paul, Duesseldorf, Germany
Dickow Pump Co., Marietta, GA

GEA GROUP, 9165 Rumsey Road, Columbia, MD 21045 (800-722-6622; www.gea.com)
—See our ad on page 23

GORMAN-RUPP PUMPS, P.O. Box 1217, Mansfield, OH 44901-1217 (419-755-1011; FAX: 419-755-1251; g-sales@gormanrump.com; www.grpumps.com)

POMPETRAVINI SPA, via per turbigo 44, Castano Primo, Italy 20022 (+39 0331 889 000; FAX: +39 0331 889 057)
—See our ad on page 47

Pumps, leakproof

Dickow Pump Co., Marietta, GA
Hermetic-Pumpen GmbH, Gundelfingen, Germany

PUMPS, OTHER

Pumps, acid, corrosive

Dickow Pump Co., Marietta, GA
GORMAN-RUPP PUMPS, P.O. Box 1217, Mansfield, OH 44901-1217 (419-755-1011; FAX: 419-755-1251; g-sales@gormanrump.com; www.grpumps.com)

Hermetic-Pumpen GmbH, Gundelfingen, Germany
JLS INTERNATIONAL, INC., 381 Fawn Lane, West Jefferson, NC 28694 (336-877-5571; FAX: 336-877-5579)

KNF NEUBERGER, INC., 2 Black Forest Rd., Trenton, NJ 08691-1810 (609-890-8600; knfusa@knf.com; www.knfusa.com)

LEWA GmbH, Leonberg, Germany
PLAST-O-MATIC VALVES INC., 1384 Pompton Ave., Cedar Grove, NJ 07009-1095 (973-256-3000; FAX: 973-256-4745)
—See our ad on page 33

—See our ad on page 33

Pumps, air driven

ROLL REYNOLDS CO. INC., Six Campus Drive, Parsippany, NJ 07054 (908-232-4200; FAX: 908-232-2146; info@roll.com; www.roll.com)

KNF NEUBERGER, INC., 2 Black Forest Rd., Trenton, NJ 08691-1810 (609-890-8600; knfusa@knf.com; www.knfusa.com)

PLAST-O-MATIC VALVES INC., 1384 Pompton Ave., Cedar Grove, NJ 07009-1095 (973-256-3000; FAX: 973-256-4745)
—See our ad on page 33

—See our ad on page 33

Pumps, axial flow

Tuthill Vacuum & Blower Systems, Springfield, MO

Pumps, battery-powered

KNF NEUBERGER, INC., 2 Black Forest Rd., Trenton, NJ 08691-1810 (609-890-8600; knfusa@knf.com; www.knfusa.com)

Pumps, canned motor

KNF NEUBERGER, INC., 2 Black Forest Rd., Trenton, NJ 08691-1810 (609-890-8600; knfusa@knf.com; www.knfusa.com)

Pumps, carboy or drum

KNF NEUBERGER, INC., 2 Black Forest Rd., Trenton, NJ 08691-1810 (609-890-8600; knfusa@knf.com; www.knfusa.com)

Pumps, condensate return

TLV CORPORATION, 13901 S. Lakes Dr., Charlotte, NC 28273 (704-597-9070; FAX: 704-583-1610; www.tlv.com)
—See our ad on page 65

—See our ad on page 65

Pumps, dry vacuum

KNF NEUBERGER, INC., 2 Black Forest Rd., Trenton, NJ 08691-1810 (609-890-8600; knfusa@knf.com; www.knfusa.com)

Pfeiffer Vacuum GmbH, Asslar, Germany
Tuthill Vacuum & Blower Systems, Springfield, MO
VACUUBRAND, INC., 11 Bokum Rd., Essex, CT 06426 (860-767-5341; www.vacuubrand.com)

Pumps, explosion proof

BOERGER GMBH ROTARY LOBE PUMPS, Benning-sweg 24, Borken-Weseke, Germany 46325 (+49 2862 9103-0; FAX: +49 2862 9103-46; www.boerger.com)

Bungartz GmbH & Co. KG, Paul, Duesseldorf, Germany
GEA GROUP, 9165 Rumsey Road, Columbia, MD 21045 (800-722-6622; www.gea.com)
—See our ad on page 23

GORMAN-RUPP PUMPS, P.O. Box 1217, Mansfield, OH 44901-1217 (419-755-1011; FAX: 419-755-1251; g-sales@gormanrump.com; www.grpumps.com)

KNF NEUBERGER, INC., 2 Black Forest Rd., Trenton, NJ 08691-1810 (609-890-8600; knfusa@knf.com; www.knfusa.com)

Pumps, hand

GORMAN-RUPP PUMPS, P.O. Box 1217, Mansfield, OH 44901-1217 (419-755-1011; FAX: 419-755-1251; g-sales@gormanrupp.com; www.grpumps.com)

Pumps, high pressure

GEA GROUP, 9165 Rumsey Road, Columbia, MD 21045 (800-722-6622; www.gea.com)

— See our ad on page 23

GORMAN-RUPP PUMPS, P.O. Box 1217, Mansfield, OH 44901-1217 (419-755-1011; FAX: 419-755-1251; g-sales@gormanrupp.com; www.grpumps.com)

JLS INTERNATIONAL, INC., 381 Fawn Lane, West Jefferson, NC 28694 (336-877-5571; FAX: 336-877-5579)

LEWA GmbH, Leonberg, Germany

POMPETRAVINI SPA, via per turbigo 44, Castano Primo, Italy 20022 (+39 0331 889 000; FAX: +39 0331 889 057)

— See our ad on page 47

Pumps, jacketed

Bungartz GmbH & Co. KG, Paul, Duesseldorf, Germany
Hermetic-Pumpen GmbH, Gundelfingen, Germany
LEWA GmbH, Leonberg, Germany

Pumps, magnetically driven

Bungartz GmbH & Co. KG, Paul, Duesseldorf, Germany
JLS INTERNATIONAL, INC., 381 Fawn Lane, West Jefferson, NC 28694 (336-877-5571; FAX: 336-877-5579)

POMPETRAVINI SPA, via per turbigo 44, Castano Primo, Italy 20022 (+39 0331 889 000; FAX: +39 0331 889 057)

— See our ad on page 47

Pumps, oil free

KNF NEUBERGER, INC., 2 Black Forest Rd., Trenton, NJ 08691-1810 (609-890-8600; knfusa@knf.com; www.knfusa.com)

Pumps, open impeller

GEA GROUP, 9165 Rumsey Road, Columbia, MD 21045 (800-722-6622; www.gea.com)

— See our ad on page 23

POMPETRAVINI SPA, via per turbigo 44, Castano Primo, Italy 20022 (+39 0331 889 000; FAX: +39 0331 889 057)

— See our ad on page 47

Pumps, other

KNF NEUBERGER, INC., 2 Black Forest Rd., Trenton, NJ 08691-1810 (609-890-8600; knfusa@knf.com; www.knfusa.com)

Pumps, peristaltic

BLUE-WHITE INDUSTRIES, 5300 Business Drive, Huntington Beach, CA 92649 (714-893-8529; FAX: 714-895-9492; sales@blue-white.com; www.blue-white.com)

Pumps, pressure powered

TLV CORPORATION, 13901 S. Lakes Dr., Charlotte, NC 28273 (704-597-9070; FAX: 704-583-1610; www.tlv.com)

— See our ad on page 65

Pumps, sealless

JLS INTERNATIONAL, INC., 381 Fawn Lane, West Jefferson, NC 28694 (336-877-5571; FAX: 336-877-5579)

LEWA GmbH, Leonberg, Germany

Pumps, sludge

ACCA Pumps, Katy, TX

GORMAN-RUPP PUMPS, P.O. Box 1217, Mansfield, OH 44901-1217 (419-755-1011; FAX: 419-755-1251; g-sales@gormanrupp.com; www.grpumps.com)

Komline-Sanderson Corp., 12 Holland Ave., Peapack, NJ 07977 (908-234-1000; FAX: 908-234-9487)

— See our ad on page 69

Pumps, slurry

GORMAN-RUPP PUMPS, P.O. Box 1217, Mansfield, OH 44901-1217 (419-755-1011; FAX: 419-755-1251; g-sales@gormanrupp.com; www.grpumps.com)

METSO MINERALS INDUSTRIES, INC., 2715 Pleasant Valley Road, York, PA 17402 (717-843-8671; FAX: 717-845-5154; www.metso.com)

— See our ad on page 39

Pumps, transfer

GEA GROUP, 9165 Rumsey Road, Columbia, MD 21045 (800-722-6622; www.gea.com)

— See our ad on page 23

GORMAN-RUPP PUMPS, P.O. Box 1217, Mansfield, OH 44901-1217 (419-755-1011; FAX: 419-755-1251; g-sales@gormanrupp.com; www.grpumps.com)

JLS INTERNATIONAL, INC., 381 Fawn Lane, West Jefferson, NC 28694 (336-877-5571; FAX: 336-877-5579)

KNF NEUBERGER, INC., 2 Black Forest Rd., Trenton, NJ 08691-1810 (609-890-8600; knfusa@knf.com; www.knfusa.com)

Pumps, water

ACCA Pumps, Katy, TX

GORMAN-RUPP PUMPS, P.O. Box 1217, Mansfield, OH 44901-1217 (419-755-1011; FAX: 419-755-1251; g-sales@gormanrupp.com; www.grpumps.com)

KNF NEUBERGER, INC., 2 Black Forest Rd., Trenton, NJ 08691-1810 (609-890-8600; knfusa@knf.com; www.knfusa.com)

PUMPS, PROPORTIONING

Pumps, diaphragm (proportioning)

BLUE-WHITE INDUSTRIES, 5300 Business Drive, Huntington Beach, CA 92649 (714-893-8529; FAX: 714-895-9492; sales@blue-white.com; www.blue-white.com)

Pumps, metering

BLUE-WHITE INDUSTRIES, 5300 Business Drive, Huntington Beach, CA 92649 (714-893-8529; FAX: 714-895-9492; sales@blue-white.com; www.blue-white.com)

LEWA GmbH, Leonberg, Germany

Dry. Heat. Cool. Filter. Wash. Dewater.



Komline-Sanderson develops, designs and manufactures innovative solutions for industrial process/production filtration, drying and heat transfer applications. For industrial and municipal wastewater treatment plants we offer membrane filtration, clarification, sludge dewatering and sludge drying technology.

Our experience ranges from simple one machine installations to complex multi-step processes and systems.

Paddle Dryer • Paddle Processor Paddle Cooler

- indirect heating using steam or thermal fluid
- indirect cooling with water/glycol
- high heat transfer rates
- low residual moisture (solvent)
- uniform heating and cooling
- controlled environment



Rotary Atomizer

- spray dryers
- dry scrubbers
- direct drive, variable speed



Vacuum Filters

- continuous filtration
- thin or thick slurries
- corrosive slurries
- cake washing



Membrane Filtration

- In house design & build
- Membrane system parts & service



(800) CALL-4-KS
www.komline.com



Komline

For details visit adlinks.chemengonline.com/80076-18

PLAST-O-MATIC VALVES INC., 1384 Pompton Ave., Cedar Grove, NJ 07009-1095 (973-256-3000; FAX: 973-256-4745)

—See our ad on page 33

PUMPS, RECIPROCATING

Pumps, diaphragm (reciprocating)

BLUE-WHITE INDUSTRIES, 5300 Business Drive, Huntington Beach, CA 92649 (714-893-8529; FAX: 714-895-9492; sales@blue-white.com; www.blue-white.com)

KNF NEUBERGER, INC., 2 Black Forest Rd., Trenton, NJ 08691-1810 (609-890-8600; knfusa@knf.com; www.knfusa.com)

Pumps, piston

KNF NEUBERGER, INC., 2 Black Forest Rd., Trenton, NJ 08691-1810 (609-890-8600; knfusa@knf.com; www.knfusa.com)

PLAST-O-MATIC VALVES INC., 1384 Pompton Ave., Cedar Grove, NJ 07009-1095 (973-256-3000; FAX: 973-256-4745)

—See our ad on page 33

Pumps, piston-diaphragm

KNF NEUBERGER, INC., 2 Black Forest Rd., Trenton, NJ 08691-1810 (609-890-8600; knfusa@knf.com; www.knfusa.com)

PUMPS, ROTARY

Pumps, gear

GORMAN-RUPP PUMPS, P.O. Box 1217, Mansfield, OH 44901-1217 (419-755-1011; FAX: 419-755-1251; gr-sales@gormanrupp.com; www.grpumps.com)

JLS INTERNATIONAL, INC., 381 Fawn Lane, West Jefferson, NC 28694 (336-877-5571; FAX: 336-877-5579)

Pumps, lobe

Capovani Brothers Inc., Scotia, NY
GEA GROUP, 9165 Rumsey Road, Columbia, MD 21045 (800-722-6622; www.gea.com)

—See our ad on page 23

Pumps, progressing cavity

ACCA Pumps, Katy, TX

Pumps, rotary liquid ring

POMPETRAVAINI SPA, via per turbigo 44, Castano Primo, Italy 20022 (+39 0331 889 000; FAX: +39 0331 889 057)

—See our ad on page 47

Pumps, rotary positive displacement

BOERGER GMBH ROTARY LOBE PUMPS, Benning-sweg 24, Borken-Weseke, Germany 46325 (+49 2862 9103-0; FAX: +49 2862 9103-46; www.boerger.com)
GORMAN-RUPP PUMPS, P.O. Box 1217, Mansfield, OH 44901-1217 (419-755-1011; FAX: 419-755-1251; gr-sales@gormanrupp.com; www.grpumps.com)

Rotary Lobe Pumps

BOERGER GMBH ROTARY LOBE PUMPS, Benning-sweg 24, Borken-Weseke, Germany 46325 (+49 2862 9103-0; FAX: +49 2862 9103-46; www.boerger.com)

PUMPS, SPECIAL MATERIALS

Pumps, ceramic

KNF NEUBERGER, INC., 2 Black Forest Rd., Trenton, NJ 08691-1810 (609-890-8600; knfusa@knf.com; www.knfusa.com)

Pumps, nonmetallic

KNF NEUBERGER, INC., 2 Black Forest Rd., Trenton, NJ 08691-1810 (609-890-8600; knfusa@knf.com; www.knfusa.com)

Pumps, other special materials

GEA GROUP, 9165 Rumsey Road, Columbia, MD 21045 (800-722-6622; www.gea.com)

—See our ad on page 23

GORMAN-RUPP PUMPS, P.O. Box 1217, Mansfield, OH 44901-1217 (419-755-1011; FAX: 419-755-1251; gr-sales@gormanrupp.com; www.grpumps.com)

JLS INTERNATIONAL, INC., 381 Fawn Lane, West Jefferson, NC 28694 (336-877-5571; FAX: 336-877-5579)
KNF NEUBERGER, INC., 2 Black Forest Rd., Trenton, NJ 08691-1810 (609-890-8600; knfusa@knf.com; www.knfusa.com)

Pumps, plastic

KNF NEUBERGER, INC., 2 Black Forest Rd., Trenton, NJ 08691-1810 (609-890-8600; knfusa@knf.com; www.knfusa.com)

PLAST-O-MATIC VALVES INC., 1384 Pompton Ave., Cedar Grove, NJ 07009-1095 (973-256-3000; FAX: 973-256-4745)

—See our ad on page 33

Pumps, stainless steel

GORMAN-RUPP PUMPS, P.O. Box 1217, Mansfield, OH 44901-1217 (419-755-1011; FAX: 419-755-1251; gr-sales@gormanrupp.com; www.grpumps.com)

KNF NEUBERGER, INC., 2 Black Forest Rd., Trenton, NJ 08691-1810 (609-890-8600; knfusa@knf.com; www.knfusa.com)

PUMPS, VACUUM & EJECTOR

Pumps, vacuum, dry

A-VAC INDUSTRIES, NC., Anaheim, CA
BUSCH VACUUM SOLUTIONS, 516 Viking Dr., Virginia Beach, VA 23452 (800-872-7867; FAX: 757-463-7407; www.buschvacuum.com)

KNF NEUBERGER, INC., 2 Black Forest Rd., Trenton, NJ 08691-1810 (609-890-8600; knfusa@knf.com; www.knfusa.com)

VACUUBRAND, INC., 11 Bokum Rd., Essex, CT 06426 (860-767-5341; www.vacuubrand.com)

Pumps, vacuum, liquid ring

AAHANA Giffard Systems, Mannheim., Baden-Württemberg, Germany

BUSCH VACUUM SOLUTIONS, 516 Viking Dr., Virginia Beach, VA 23452 (800-872-7867; FAX: 757-463-7407; www.buschvacuum.com)

KNF NEUBERGER, INC., 2 Black Forest Rd., Trenton, NJ 08691-1810 (609-890-8600; knfusa@knf.com; www.knfusa.com)

VACUUBRAND, INC., 11 Bokum Rd., Essex, CT 06426 (860-767-5341; www.vacuubrand.com)

Pumps, vacuum, once-through-oil

BUSCH VACUUM SOLUTIONS, 516 Viking Dr., Virginia Beach, VA 23452 (800-872-7867; FAX: 757-463-7407; www.buschvacuum.com)

Pumps, vacuum, other

A-VAC INDUSTRIES, NC., Anaheim, CA
BUSCH VACUUM SOLUTIONS, 516 Viking Dr., Virginia Beach, VA 23452 (800-872-7867; FAX: 757-463-7407; www.buschvacuum.com)

CROLL REYNOLDS CO. INC., Six Campus Drive, Parsippany, NJ 07054 (908-232-4200; FAX: 908-232-2146; info@croll.com; www.croll.com)

GEA GROUP, 9165 Rumsey Road, Columbia, MD 21045 (800-722-6622; www.gea.com)

—See our ad on page 23

KNF NEUBERGER, INC., 2 Black Forest Rd., Trenton, NJ 08691-1810 (609-890-8600; knfusa@knf.com; www.knfusa.com)

KOERTING HANNOVER GMBH, Badenstedter Str. 56, Hannover, Germany 30453 (0511-2129-0; FAX: 0511-2129-223)

—See our ad on page 69

TLV CORPORATION, 13901 S. Lakes Dr., Charlotte, NC 28273 (704-597-9070; FAX: 704-583-1610; www.tlv.com)

—See our ad on page 65

Pumps, vacuum, rotary piston

A-VAC INDUSTRIES, NC., Anaheim, CA

Steam jet ejectors

AAHANA Giffard Systems, Mannheim., Baden-Württemberg, Germany

CROLL REYNOLDS

PROCESS VACUUM

CROLL REYNOLDS CO. INC., Six Campus Drive, Parsippany, NJ 07054 (908-232-4200; FAX: 908-232-2146; info@croll.com; www.croll.com)

GEA GROUP, 9165 Rumsey Road, Columbia, MD 21045 (800-722-6622; www.gea.com)

—See our ad on page 23

JLS INTERNATIONAL, INC., 381 Fawn Lane, West Jefferson, NC 28694 (336-877-5571; FAX: 336-877-5579)

KOERTING HANNOVER GMBH, Badenstedter Str. 56, Hannover, Germany 30453 (0511-2129-0; FAX: 0511-2129-223)

—See our ad on page 69

Vacuum pumping systems

A-VAC INDUSTRIES, NC., Anaheim, CA

AAHANA Giffard Systems, Mannheim., Baden-Württemberg, Germany

BUSCH VACUUM SOLUTIONS, 516 Viking Dr., Virginia Beach, VA 23452 (800-872-7867; FAX: 757-463-7407; www.buschvacuum.com)

CROLL REYNOLDS CO. INC., Six Campus Drive, Parsippany, NJ 07054 (908-232-4200; FAX: 908-232-2146; info@croll.com; www.croll.com)

GEA GROUP, 9165 Rumsey Road, Columbia, MD 21045 (800-722-6622; www.gea.com)

—See our ad on page 23

KNF NEUBERGER, INC., 2 Black Forest Rd., Trenton, NJ 08691-1810 (609-890-8600; knfusa@knf.com; www.knfusa.com)

KOERTING HANNOVER GMBH, Badenstedter Str. 56, Hannover, Germany 30453 (0511-2129-0; FAX: 0511-2129-223)

—See our ad on page 69

POMPETRAVAINI SPA, via per turbigo 44, Castano Primo, Italy 20022 (+39 0331 889 000; FAX: +39 0331 889 057)

—See our ad on page 47

VACUUBRAND, INC., 11 Bokum Rd., Essex, CT 06426 (860-767-5341; www.vacuubrand.com)

PUMPS, VERTICAL & DEEP WELL

Pumps, submersible

BOERGER GMBH ROTARY LOBE PUMPS, Benning-sweg 24, Borken-Weseke, Germany 46325 (+49 2862 9103-0; FAX: +49 2862 9103-46; www.boerger.com)

GORMAN-RUPP PUMPS, P.O. Box 1217, Mansfield, OH 44901-1217 (419-755-1011; FAX: 419-755-1251; gr-sales@gormanrupp.com; www.grpumps.com)

Pumps, pump

GORMAN-RUPP PUMPS, P.O. Box 1217, Mansfield, OH 44901-1217 (419-755-1011; FAX: 419-755-1251; gr-sales@gormanrupp.com; www.grpumps.com)

Pumps, vertical centrifugal

GEA GROUP, 9165 Rumsey Road, Columbia, MD 21045 (800-722-6622; www.gea.com)

—See our ad on page 23

SEALS, GASKETS & PACKING MATERIALS

Gaskets, fluoroplastic

PROCO PRODUCTS, INC., 2431 N. Wigwam Dr., Stockton, CA 95205 (209-943-6088; FAX: 209-943-0242; www.procoproducts.com)

Gaskets, rubber

PROCO PRODUCTS, INC., 2431 N. Wigwam Dr., Stockton, CA 95205 (209-943-6088; FAX: 209-943-0242; www.procoproducts.com)

Packings, plastic

KOCH-GLITSCH, INC., 4111 E. 37th St. N., Wichita, KS 67220 (316-828-5110; FAX: 316-828-7985)

—See our ad inside front cover

Packings, random

KOCH-GLITSCH, INC., 4111 E. 37th St. N., Wichita, KS 67220 (316-828-5110; FAX: 316-828-7985)

—See our ad inside front cover

SAINT-GOBAIN NORPRO CORP., 3840 Fishcreek Road, Stow, OH 44224 (330-673-5860; FAX: 330-677-7245; www.saintgobain.com)

Packings, ring

KOCH-GLITSCH, INC., 4111 E. 37th St. N., Wichita, KS 67220 (316-828-5110; FAX: 316-828-7985)

—See our ad inside front cover

Seals, balanced pressure

EKATO RUEHR- UND MISCHTECHNIK GMBH, Hohe-Flum-Str.37, Schopfheim, Germany D-79650 (+49 7622 290; FAX: +49 7622 29 213; www.ekato.com)

—See our ad on page 84

FLUID LINE PRODUCTS INC., 38273 Western Pkwy., P.O. Box 1000, Willoughby, OH 44096 (440-946-9470; FAX: 440-946-9472; www.fluidline.com)

Seals, bearing

ACS Industries Inc., Lincoln, RI
EKATO RUEHR- UND MISCHTECHNIK GMBH, Hohe-Flum-Str.37, Schopfheim, Germany D-79650 (+49 7622 290; FAX: +49 7622 29 213; www.ekato.com)

—See our ad on page 84

FLUID LINE PRODUCTS INC., 38273 Western Pkwy., P.O. Box 1000, Willoughby, OH 44096 (440-946-9470; FAX: 440-946-9472; www.fluidline.com)

Seals, magnetic

EKATO RUEHR- UND MISCHTECHNIK GMBH, Hohe-Flum-Str.37, Schopfheim, Germany D-79650 (+49 7622 290; FAX: +49 7622 29 213; www.ekato.com)

—See our ad on page 84

FLUID LINE PRODUCTS INC., 38273 Western Pkwy., P.O. Box 1000, Willoughby, OH 44096 (440-946-9470; FAX: 440-946-9472; www.fluidline.com)

Seals, mechanical

EKATO RUEHR- UND MISCHTECHNIK GMBH, Hohe-Flum-Str.37, Schopfheim, Germany D-79650 (+49 7622 290; FAX: +49 7622 29 213; www.ekato.com)

—See our ad on page 84

FLUID LINE PRODUCTS INC., 38273 Western Pkwy., P.O. Box 1000, Willoughby, OH 44096 (440-946-9470; FAX: 440-946-9472; www.fluidline.com)

STEAM TRAPS

Steam traps, disc

TLV CORPORATION, 13901 S. Lakes Dr., Charlotte, NC 28273 (704-597-9070; FAX: 704-583-1610; www.tlv.com)

—See our ad on page 65

Steam traps, float

TLV CORPORATION, 13901 S. Lakes Dr., Charlotte, NC 28273 (704-597-9070; FAX: 704-583-1610; www.tlv.com)

—See our ad on page 65

Steam traps, float & thermostatic

TLV CORPORATION, 13901 S. Lakes Dr., Charlotte, NC 28273 (704-597-9070; FAX: 704-583-1610; www.tlv.com)

—See our ad on page 65

Steam traps, inverted bucket

TLV CORPORATION, 13901 S. Lakes Dr., Charlotte, NC 28273 (704-597-9070; FAX: 704-583-1610; www.tlv.com)

—See our ad on page 65

Steam traps, thermostatic

TLV CORPORATION, 13901 S. Lakes Dr., Charlotte, NC 28273 (704-597-9070; FAX: 704-583-1610; www.tlv.com)

—See our ad on page 65

TANKS & OTHER LIQUID STORAGE VESSELS

Tank fittings & accessories

CAST-X Circulation Heaters, Batavia, IL

Tanks, carbon steel

ROSS MIXERS, 710 Old Willets Path, P.O. Box 12308, Hauppauge, NY 11788-0615 (631-234-0500; FAX: 631-234-0691; www.mixers.com)

Tanks, cryogenic

POPE SCIENTIFIC, INC., P.O. Box 80018, 351 N. Dekora Woods Blvd., Saukville, WI 53080 (262-268-9300; FAX: 262-268-9400; info@popeinc.com; www.popeinc.com)

Tanks, cryogenic, vacuum jacketed

POPE SCIENTIFIC, INC., P.O. Box 80018, 351 N. Dekora Woods Blvd., Saukville, WI 53080 (262-268-9300; FAX: 262-268-9400; info@popeinc.com; www.popeinc.com)

ROSS MIXERS, 710 Old Willets Path, P.O. Box 12308, Hauppauge, NY 11788-0615 (631-234-0500; FAX: 631-234-0691; www.mixers.com)

Tanks, custom fabricated

POPE SCIENTIFIC, INC., P.O. Box 80018, 351 N. Dekora Woods Blvd., Saukville, WI 53080 (262-268-9300; FAX: 262-268-9400; info@popeinc.com; www.popeinc.com)

ROSS MIXERS, 710 Old Willets Path, P.O. Box 12308, Hauppauge, NY 11788-0615 (631-234-0500; FAX: 631-234-0691; www.mixers.com)

Tanks, dimple jacketed

POPE SCIENTIFIC, INC., P.O. Box 80018, 351 N. Dekora Woods Blvd., Saukville, WI 53080 (262-268-9300; FAX: 262-268-9400; info@popeinc.com; www.popeinc.com)

ROSS MIXERS, 710 Old Willets Path, P.O. Box 12308, Hauppauge, NY 11788-0615 (631-234-0500; FAX: 631-234-0691; www.mixers.com)

Tanks, heated

CAST-X Circulation Heaters, Batavia, IL

POPE SCIENTIFIC, INC., P.O. Box 80018, 351 N. Dekora Woods Blvd., Saukville, WI 53080 (262-268-9300; FAX: 262-268-9400; info@popeinc.com; www.popeinc.com)

Water Heating Direct, Fort Worth, TX

Tanks, mixing

JAYGO, INC., 7 Emery Ave., Randolph, NJ 07869 (908-688-3600; FAX: 908-688-6060)

POPE SCIENTIFIC, INC., P.O. Box 80018, 351 N. Dekora Woods Blvd., Saukville, WI 53080 (262-268-9300; FAX: 262-268-9400; info@popeinc.com; www.popeinc.com)

ROSS MIXERS, 710 Old Willets Path, P.O. Box 12308, Hauppauge, NY 11788-0615 (631-234-0500; FAX: 631-234-0691; www.mixers.com)

Tanks, pressurized storage

Fluitron, Inc., Ivyland, PA

POPE SCIENTIFIC, INC., P.O. Box 80018, 351 N. Dekora Woods Blvd., Saukville, WI 53080 (262-268-9300; FAX: 262-268-9400; info@popeinc.com; www.popeinc.com)

ROSS MIXERS, 710 Old Willets Path, P.O. Box 12308, Hauppauge, NY 11788-0615 (631-234-0500; FAX: 631-234-0691; www.mixers.com)

Tanks, stainless steel

POPE SCIENTIFIC, INC., P.O. Box 80018, 351 N. Dekora Woods Blvd., Saukville, WI 53080 (262-268-9300; FAX: 262-268-9400; info@popeinc.com; www.popeinc.com)

ROSS MIXERS, 710 Old Willets Path, P.O. Box 12308, Hauppauge, NY 11788-0615 (631-234-0500; FAX: 631-234-0691; www.mixers.com)

Tanks, stainless steel, lined

POPE SCIENTIFIC, INC., P.O. Box 80018, 351 N. Dekora Woods Blvd., Saukville, WI 53080 (262-268-9300; FAX: 262-268-9400; info@popeinc.com; www.popeinc.com)

Tanks, tapered wall

ROSS MIXERS, 710 Old Willets Path, P.O. Box 12308, Hauppauge, NY 11788-0615 (631-234-0500; FAX: 631-234-0691; www.mixers.com)

TUBING & TUBE FITTINGS, METALLIC & NONMETALLIC

Coils, tubing

Ametek Fluoropolymer Products, Nesquehoning, PA
CAST-X Circulation Heaters, Batavia, IL

Tube fittings

CAST-X Circulation Heaters, Batavia, IL
SWAGelok CO., 29500 Solon Road, Solon, OH 44139-2764 (440-248-4600; www.swagelok.com)
Tylok Fittings & Valves, Cleveland, OH

Tubing, condenser

Ametek Fluoropolymer Products, Nesquehoning, PA

Tubing, evaporator

Ametek Fluoropolymer Products, Nesquehoning, PA
CAST-X Circulation Heaters, Batavia, IL

Tubing, finned

FIN TUBE PRODUCTS, INC., 188 S Lyman St., Suite 100, Wadsworth, OH 44281 (330-334-3736; FAX: 330-334-3848; mb@fintube.com; www.fintube.com)

Tubing, heat exchanger

CAST-X Circulation Heaters, Batavia, IL
FIN TUBE PRODUCTS, INC., 188 S Lyman St., Suite 100, Wadsworth, OH 44281 (330-334-3736; FAX: 330-334-3848; mb@fintube.com; www.fintube.com)

Tubing, high pressure

CAST-X Circulation Heaters, Batavia, IL

Tubing, high temperature

CAST-X Circulation Heaters, Batavia, IL

VALVES

Valves, air

CHECK-ALL VALVE MFG. CO., 1800 Fuller Rd., West Des Moines, IA 50265 (515-224-2301; FAX: 515-224-2326; www.checkall.com)

PLAST-O-MATIC VALVES INC., 1384 Pompton Ave., Cedar Grove, NJ 07009-1095 (973-256-3000; FAX: 973-256-4745)

—See our ad on page 33

Valves, angle

ARCA Regler GmbH, Toenisvorst, Germany

CASHCO, INC., P.O. Box 6, 607 W. 15th, Ellsworth, KS 67439-0006 (785-472-4461; FAX: 785-472-3539; www.cashco.com)

OHL Guterath Industrial Valves GmbH, Altenstadt, Germany

PLAST-O-MATIC VALVES INC., 1384 Pompton Ave., Cedar Grove, NJ 07009-1095 (973-256-3000; FAX: 973-256-4745)

—See our ad on page 33

Valves, ball

Conval, Inc., Enfield, CT

JAYGO, INC., 7 Emery Ave., Randolph, NJ 07869 (908-688-3600; FAX: 908-688-6060)

Metso Flow Control Inc, Vantaa, Finland

PLAST-O-MATIC VALVES INC., 1384 Pompton Ave., Cedar Grove, NJ 07009-1095 (973-256-3000; FAX: 973-256-4745)

—See our ad on page 33

SWAGelok CO., 29500 Solon Road, Solon, OH 44139-2764 (440-248-4600; www.swagelok.com)

Tylok Fittings & Valves, Cleveland, OH

Valves, bellows sealed

ARCA Regler GmbH, Toenisvorst, Germany

BIAR SAMPLING SYSTEMS, 2506 S. Philippe Ave., Gonzales, LA 70737 (225-647-4300; contact@biar.us; www.biar.us)

CASHCO, INC., P.O. Box 6, 607 W. 15th, Ellsworth, KS 67439-0006 (785-472-4461; FAX: 785-472-3539; www.cashco.com)

150 YEARS OF KÖRTING

Leading technologies in vacuum and environmental engineering

+49 511 2129-0 | sales@koerting.de

For details visit adlinks.chemengonline.com/80076-17

PLAST-O-MATIC VALVES INC., 1384 Pompton Ave., Cedar Grove, NJ 07009-1095 (973-256-3000; FAX: 973-256-4745)

—See our ad on page 33
Valcor Engineering Corp, Springfield, NJ

Valves, butterfly

CASHCO, INC., P.O. Box 6, 607 W. 15th, Ellsworth, KS 67439-0006 (785-472-4461; FAX: 785-472-3539; www.cashco.com)

GEA GROUP, 9165 Rumsey Road, Columbia, MD 21045 (800-722-6622; www.gea.com)

—See our ad on page 23
Metso Flow Control Inc, Vantaa, Finland
OHL Guterth Industrial Valves GmbH, Altenstadt, Germany

POSI-FLATE, 1125 Willow Lake Blvd., St. Paul, MN 55110-5193 (651-484-5800; FAX: 651-484-7015; www.posiflate.com)

Valves, check

CHECK-ALL VALVE MFG. CO., 1800 Fuller Rd., West Des Moines, IA 50265 (515-224-2301; FAX: 515-224-2326; www.checkall.com)

PLAST-O-MATIC VALVES INC., 1384 Pompton Ave., Cedar Grove, NJ 07009-1095 (973-256-3000; FAX: 973-256-4745)

—See our ad on page 33
TLV CORPORATION, 13901 S. Lakes Dr., Charlotte, NC 28273 (704-597-9070; FAX: 704-583-1610; www.tlv.com)

Valves, control, electric

AUMA RIESTER GMBH & CO. KG, Aumastrasse 1, Muellheim, Germany 79379 (+49 7631 8091250; www.auma.com)

CASHCO, INC., P.O. Box 6, 607 W. 15th, Ellsworth, KS 67439-0006 (785-472-4461; FAX: 785-472-3539; www.cashco.com)

PLAST-O-MATIC VALVES INC., 1384 Pompton Ave., Cedar Grove, NJ 07009-1095 (973-256-3000; FAX: 973-256-4745)

—See our ad on page 33

Valves, control, hydraulic

PLAST-O-MATIC VALVES INC., 1384 Pompton Ave., Cedar Grove, NJ 07009-1095 (973-256-3000; FAX: 973-256-4745)

—See our ad on page 33

Valves, control, pneumatic

ARCA Regler GmbH, Toenisvorst, Germany

CASHCO, INC., P.O. Box 6, 607 W. 15th, Ellsworth, KS 67439-0006 (785-472-4461; FAX: 785-472-3539; www.cashco.com)

COLLINS INSTRUMENT CO INC., P.O. Box 938, Angleton, TX 77516 (979-849-8266; FAX: 979-848-0783; www.collinsinst.com/)

GEA GROUP, 9165 Rumsey Road, Columbia, MD 21045 (800-722-6622; www.gea.com)

—See our ad on page 23

Metso Flow Control Inc, Vantaa, Finland

PLAST-O-MATIC VALVES INC., 1384 Pompton Ave., Cedar Grove, NJ 07009-1095 (973-256-3000; FAX: 973-256-4745)

—See our ad on page 33

POSI-FLATE, 1125 Willow Lake Blvd., St. Paul, MN 55110-5193 (651-484-5800; FAX: 651-484-7015; www.posiflate.com)

Valves, control, regulator

CASHCO, INC., P.O. Box 6, 607 W. 15th, Ellsworth, KS 67439-0006 (785-472-4461; FAX: 785-472-3539; www.cashco.com)

PLAST-O-MATIC VALVES INC., 1384 Pompton Ave., Cedar Grove, NJ 07009-1095 (973-256-3000; FAX: 973-256-4745)

—See our ad on page 33

TLV CORPORATION, 13901 S. Lakes Dr., Charlotte, NC 28273 (704-597-9070; FAX: 704-583-1610; www.tlv.com)

—See our ad on page 65

Valves, control, solenoid

PLAST-O-MATIC VALVES INC., 1384 Pompton Ave., Cedar Grove, NJ 07009-1095 (973-256-3000; FAX: 973-256-4745)

—See our ad on page 33

Valcor Engineering Corp, Springfield, NJ

Valves, cryogenic

CASHCO, INC., P.O. Box 6, 607 W. 15th, Ellsworth, KS 67439-0006 (785-472-4461; FAX: 785-472-3539; www.cashco.com)

CHECK-ALL VALVE MFG. CO., 1800 Fuller Rd., West Des Moines, IA 50265 (515-224-2301; FAX: 515-224-2326; www.checkall.com)

Valves, diaphragm

GEMU Valves, Inc., Atlanta, GA

PLAST-O-MATIC VALVES INC., 1384 Pompton Ave., Cedar Grove, NJ 07009-1095 (973-256-3000; FAX: 973-256-4745)

—See our ad on page 33

Valves, diverter

JLS INTERNATIONAL, INC., 381 Fawn Lane, West Jefferson, NC 28694 (336-877-5571; FAX: 336-877-5579)

OHL Guterth Industrial Valves GmbH, Altenstadt, Germany
PLAST-O-MATIC VALVES INC., 1384 Pompton Ave., Cedar Grove, NJ 07009-1095 (973-256-3000; FAX: 973-256-4745)

—See our ad on page 33

Vortex, Salina, KS

Valves, double block & bleed

OHL Guterth Industrial Valves GmbH, Altenstadt, Germany
SWAGELOK CO., 29500 Solon Road, Solon, OH 44139-2764 (440-248-4600; www.swagelok.com)

Valves, flush-bottom tank

JLS INTERNATIONAL, INC., 381 Fawn Lane, West Jefferson, NC 28694 (336-877-5571; FAX: 336-877-5579)

Valves, gate

Vortex, Salina, KS

Valves, globe

CASHCO, INC., P.O. Box 6, 607 W. 15th, Ellsworth, KS 67439-0006 (785-472-4461; FAX: 785-472-3539; www.cashco.com)

Conval, Inc., Enfield, CT
GEMU Valves, Inc., Atlanta, GA

PLAST-O-MATIC VALVES INC., 1384 Pompton Ave., Cedar Grove, NJ 07009-1095 (973-256-3000; FAX: 973-256-4745)

—See our ad on page 33

Valves, high pressure

CHECK-ALL VALVE MFG. CO., 1800 Fuller Rd., West Des Moines, IA 50265 (515-224-2301; FAX: 515-224-2326; www.checkall.com)

Conval, Inc., Enfield, CT

JLS INTERNATIONAL, INC., 381 Fawn Lane, West Jefferson, NC 28694 (336-877-5571; FAX: 336-877-5579)

POSI-FLATE, 1125 Willow Lake Blvd., St. Paul, MN 55110-5193 (651-484-5800; FAX: 651-484-7015; www.posiflate.com)

SENTRY EQUIPMENT CORP, 966 Blue Ribbon Circle North, Oconomowoc, WI 53066 (262-567-7256; FAX: 262-567-4523)

SWAGELOK CO., 29500 Solon Road, Solon, OH 44139-2764 (440-248-4600; www.swagelok.com)

TLV CORPORATION, 13901 S. Lakes Dr., Charlotte, NC 28273 (704-597-9070; FAX: 704-583-1610; www.tlv.com)

—See our ad on page 65

Vortex, Salina, KS

WELLAND & TUXHORN AG, Gütersloher Str. 257, Bielefeld, Germany 33649 (+49 521 9418-0; FAX: +49 521 9418-156; www.welland-tuxhorn.de)

Valves, high temperature

CHECK-ALL VALVE MFG. CO., 1800 Fuller Rd., West Des Moines, IA 50265 (515-224-2301; FAX: 515-224-2326; www.checkall.com)

Conval, Inc., Enfield, CT

JLS INTERNATIONAL, INC., 381 Fawn Lane, West Jefferson, NC 28694 (336-877-5571; FAX: 336-877-5579)

SWAGELOK CO., 29500 Solon Road, Solon, OH 44139-2764 (440-248-4600; www.swagelok.com)

TLV CORPORATION, 13901 S. Lakes Dr., Charlotte, NC 28273 (704-597-9070; FAX: 704-583-1610; www.tlv.com)

—See our ad on page 65

Vortex, Salina, KS

WELLAND & TUXHORN AG, Gütersloher Str. 257, Bielefeld, Germany 33649 (+49 521 9418-0; FAX: +49 521 9418-156; www.welland-tuxhorn.de)

Valves, jacketed

JLS INTERNATIONAL, INC., 381 Fawn Lane, West Jefferson, NC 28694 (336-877-5571; FAX: 336-877-5579)

OHL Guterth Industrial Valves GmbH, Altenstadt, Germany

Valves, knife-gate

Vortex, Salina, KS

Valves, metal seated

CASHCO, INC., P.O. Box 6, 607 W. 15th, Ellsworth, KS 67439-0006 (785-472-4461; FAX: 785-472-3539; www.cashco.com)

CHECK-ALL VALVE MFG. CO., 1800 Fuller Rd., West Des Moines, IA 50265 (515-224-2301; FAX: 515-224-2326; www.checkall.com)

JLS INTERNATIONAL, INC., 381 Fawn Lane, West Jefferson, NC 28694 (336-877-5571; FAX: 336-877-5579)

Valves, motor operated

TLV CORPORATION, 13901 S. Lakes Dr., Charlotte, NC 28273 (704-597-9070; FAX: 704-583-1610; www.tlv.com)

—See our ad on page 65

Valves, multiport

JLS INTERNATIONAL, INC., 381 Fawn Lane, West Jefferson, NC 28694 (336-877-5571; FAX: 336-877-5579)

PLAST-O-MATIC VALVES INC., 1384 Pompton Ave., Cedar Grove, NJ 07009-1095 (973-256-3000; FAX: 973-256-4745)

—See our ad on page 33

Valves, needle

SWAGELOK CO., 29500 Solon Road, Solon, OH 44139-2764 (440-248-4600; www.swagelok.com)

Valcor Engineering Corp, Springfield, NJ

Valves, nuclear

Conval, Inc., Enfield, CT

Valcor Engineering Corp, Springfield, NJ

Valves, other

BIAR SAMPLING SYSTEMS, 2506 S. Philippe Ave., Gonzales, LA 70737 (225-647-4300; contact@biar.us; www.biar.us)

INDECK POWER EQUIPMENT CO., 1111 Willis Ave. (CE), Wheeling, IL 60090 (847-541-8300; FAX: 847-541-9984; www.indeck.com)

—See our ad on page 15

Valves, packless

CASHCO, INC., P.O. Box 6, 607 W. 15th, Ellsworth, KS 67439-0006 (785-472-4461; FAX: 785-472-3539; www.cashco.com)

Valves, pilot operated

CASHCO, INC., P.O. Box 6, 607 W. 15th, Ellsworth, KS 67439-0006 (785-472-4461; FAX: 785-472-3539; www.cashco.com)

PLAST-O-MATIC VALVES INC., 1384 Pompton Ave., Cedar Grove, NJ 07009-1095 (973-256-3000; FAX: 973-256-4745)

—See our ad on page 33

Valves, pinch

PLAST-O-MATIC VALVES INC., 1384 Pompton Ave., Cedar Grove, NJ 07009-1095 (973-256-3000; FAX: 973-256-4745)

—See our ad on page 33

Valves, plastic

CHECK-ALL VALVE MFG. CO., 1800 Fuller Rd., West Des Moines, IA 50265 (515-224-2301; FAX: 515-224-2326; www.checkall.com)

COLLINS INSTRUMENT CO INC., P.O. Box 938, Angleton, TX 77516 (979-849-8266; FAX: 979-848-0783; www.collinsinst.com/)

GEMU Valves, Inc., Atlanta, GA

PLAST-O-MATIC VALVES INC., 1384 Pompton Ave., Cedar Grove, NJ 07009-1095 (973-256-3000; FAX: 973-256-4745)

—See our ad on page 33

Valves, plastic lined

CHECK-ALL VALVE MFG. CO., 1800 Fuller Rd., West Des Moines, IA 50265 (515-224-2301; FAX: 515-224-2326; www.checkall.com)

Valves, plug

JAYGO, INC., 7 Emery Ave., Randolph, NJ 07869 (908-688-3600; FAX: 908-688-6060)

JLS INTERNATIONAL, INC., 381 Fawn Lane, West Jefferson, NC 28694 (336-877-5571; FAX: 336-877-5579)

Valves, pneumatic

CASHCO, INC., P.O. Box 6, 607 W. 15th, Ellsworth, KS 67439-0006 (785-472-4461; FAX: 785-472-3539; www.cashco.com)

PLAST-O-MATIC VALVES INC., 1384 Pompton Ave., Cedar Grove, NJ 07009-1095 (973-256-3000; FAX: 973-256-4745)

—See our ad on page 33

Valves, pressure reducing

CASHCO, INC., P.O. Box 6, 607 W. 15th, Ellsworth, KS 67439-0006 (785-472-4461; FAX: 785-472-3539; www.cashco.com)

PLAST-O-MATIC VALVES INC., 1384 Pompton Ave., Cedar Grove, NJ 07009-1095 (973-256-3000; FAX: 973-256-4745)

—See our ad on page 33

SENTRY EQUIPMENT CORP, 966 Blue Ribbon Circle North, Oconomowoc, WI 53066 (262-567-7256; FAX: 262-567-4523)

TLV CORPORATION, 13901 S. Lakes Dr., Charlotte, NC 28273 (704-597-9070; FAX: 704-583-1610; www.tlv.com)

—See our ad on page 65

Valves, pump protection

CHECK-ALL VALVE MFG. CO., 1800 Fuller Rd., West Des Moines, IA 50265 (515-224-2301; FAX: 515-224-2326; www.checkall.com)

PLAST-O-MATIC VALVES INC., 1384 Pompton Ave., Cedar Grove, NJ 07009-1095 (973-256-3000; FAX: 973-256-4745)

—See our ad on page 33

Valves, quick closing

PLAST-O-MATIC VALVES INC., 1384 Pompton Ave., Cedar Grove, NJ 07009-1095 (973-256-3000; FAX: 973-256-4745)

—See our ad on page 33

Valves, relief

CASHCO, INC., P.O. Box 6, 607 W. 15th, Ellsworth, KS 67439-0006 (785-472-4461; FAX: 785-472-3539; www.cashco.com)

PLAST-O-MATIC VALVES INC., 1384 Pompton Ave., Cedar Grove, NJ 07009-1095 (973-256-3000; FAX: 973-256-4745)

—See our ad on page 33

REMBE GMBH SAFETY + CONTROL, Gallbergweg 21, Brilon, Germany 59929 (+49 2961 7405-0; FAX: +49 2961 50714; www.rembe.de)

Valves, safety

WELLAND & TUXHORN AG, Gütersloher Str. 257, Bielefeld, Germany 33649 (+49 521 9418-0; FAX: +49 521 9418-156; www.welland-tuxhorn.de)

Valves, sampling

BIAR SAMPLING SYSTEMS, 2506 S. Philippe Ave., Gonzales, LA 70737 (225-647-4300; contact@biar.us; www.biar.us)

JAYGO, INC., 7 Emery Ave., Randolph, NJ 07869 (908-688-3600; FAX: 908-688-6060)

JLS INTERNATIONAL, INC., 381 Fawn Lane, West Jefferson, NC 28694 (336-877-5571; FAX: 336-877-5579)

SENTRY EQUIPMENT CORP, 966 Blue Ribbon Circle North, Oconomowoc, WI 53066 (262-567-7256; FAX: 262-567-4523)

SWAGELOK CO., 29500 Solon Road, Solon, OH 44139-2764 (440-248-4600; www.swagelok.com)

Valves, tank venting

CASHCO, INC., P.O. Box 6, 607 W. 15th, Ellsworth, KS 67439-0006 (785-472-4461; FAX: 785-472-3539; www.cashco.com)

CHECK-ALL VALVE MFG. CO., 1800 Fuller Rd., West Des Moines, IA 50265 (515-224-2301; FAX: 515-224-2326; www.checkall.com)

JLS INTERNATIONAL, INC., 381 Fawn Lane, West Jefferson, NC 28694 (336-877-5571; FAX: 336-877-5579)

Valves, titanium

CHECK-ALL VALVE MFG. CO., 1800 Fuller Rd., West Des Moines, IA 50265 (515-224-2301; FAX: 515-224-2326; www.checkall.com)

JLS INTERNATIONAL, INC., 381 Fawn Lane, West Jefferson, NC 28694 (336-877-5571; FAX: 336-877-5579)

Valves, vacuum

Capovani Brothers Inc., Scotia, NY

CHECK-ALL VALVE MFG. CO., 1800 Fuller Rd., West Des Moines, IA 50265 (515-224-2301; FAX: 515-224-2326; www.checkall.com)

PLAST-O-MATIC VALVES INC., 1384 Pompton Ave., Cedar Grove, NJ 07009-1095 (973-256-3000; FAX: 973-256-4745)

—See our ad on page 33

Valves, vacuum relief

CHECK-ALL VALVE MFG. CO., 1800 Fuller Rd., West Des Moines, IA 50265 (515-224-2301; FAX: 515-224-2326; www.checkall.com)

PLAST-O-MATIC VALVES INC., 1384 Pompton Ave., Cedar Grove, NJ 07009-1095 (973-256-3000; FAX: 973-256-4745)

—See our ad on page 33

REMBE GMBH SAFETY + CONTROL, Gallbergweg 21, Brilon, Germany 59929 (+49 2961 7405-0; FAX: +49 2961 50714; www.rembe.de)

REMBE INC., 3809 Beam Road Ste K, Charlotte, NC 28217 (+1 704 716 7022; FAX: +1 704 716 7025)

Valves, vent, low pressure

CASHCO, INC., P.O. Box 6, 607 W. 15th, Ellsworth, KS 67439-0006 (785-472-4461; FAX: 785-472-3539; www.cashco.com)

REMBE GMBH SAFETY + CONTROL, Gallbergweg 21, Brilon, Germany 59929 (+49 2961 7405-0; FAX: +49 2961 50714; www.rembe.de)

Valves, zirconium

JLS INTERNATIONAL, INC., 381 Fawn Lane, West Jefferson, NC 28694 (336-877-5571; FAX: 336-877-5579)

A Guide to Advanced and Next-Generation Battery Technology and Materials

This comprehensive guidebook provides descriptions of the major battery technologies and materials in the advanced and next-generation battery markets, as well as information on many of the companies operating in the advanced and next-generation battery industries.

Included in this guidebook is a table that represents a list of selected technology-development companies in the advanced battery space, along with their areas of focus, contact information and technology status. It lists both established companies and startup companies that have made technological strides in recent years toward commercially viable battery technologies.

- Major application areas for advanced and next-generation batteries
- Key parameters for advanced and next-generation batteries
- A sampling of academic and national laboratory research groups and lead investigators that are focused on technology for advanced batteries

Details Include:

- Driving forces
- Battery materials
- Supply-chain logistics
- Advanced batteries
- Li-ion variants
- Next-generation batteries
- Developments by application area
- Grid-energy storage
- Lithium-ion technology
- Advanced lead-acid batteries
- Wearable batteries
- Lithium-sulfur battery technology
- Redox flow batteries
- Battery materials and components
- Production capacity
- Research stage
- Advanced battery companies and specific technologies
- References

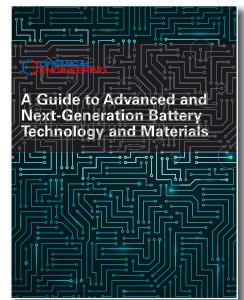

Learn more at store.chemengonline.com

28014

2

SOLIDS HANDLING

- 72 Associations
- 72 Bins & other dry storage equipment
- 72 Bulk carriers, loading & unloading equipment
- 72 Coating, forming & agglomeration equipment
- 72 Conveyors & elevators for bulk materials
- 73 Lifting equipment
- 73 Packaging equipment
- 73 Solids handling equipment & systems, other
- 74 Weighing, feeding & proportioning equipment

ASSOCIATIONS

DECHEMA E.V., Theodor-Heuss-Allee 25, Frankfurt am Main, Germany 60486 (49-69-75-64-0; FAX: 49-69-75-64-201; www.dechema.de)

—See our ad on page 22

BINS & OTHER DRY STORAGE EQUIPMENT

Bin activators

Acron, Inc.

DYNAMIC AIR INC., 1125 Willow Lake Blvd., St. Paul, MN 55110-5193 (651-484-2900; FAX: 651-484-7015; www.dynamicair.com)

Bins

HAPMAN, 6002 East N Avenue, Kalamazoo, MI 49048 (269-343-1675; FAX: 269-349-2477; sales@hapman.com; www.hapman.com)

JENIKE & JOHANSON INC., 400 Business Park Dr., Tyngsboro, MA 01879-1077 (978-649-3300; FAX: 978-649-3399)

ROSS MIXERS, 710 Old Willets Path, P.O. Box 12308, Hauppauge, NY 11788-0615 (631-234-0500; FAX: 631-234-0691; www.mixers.com)

Bins, weighing

HAPMAN, 6002 East N Avenue, Kalamazoo, MI 49048 (269-343-1675; FAX: 269-349-2477; sales@hapman.com; www.hapman.com)

SCHENCK PROCESS, 7901 NW 107th Terrace, Kansas City, MO 64153 (816-891-9300; FAX: 816-891-8336; www.schenckprocess.com)

Gates, hopper

JENIKE & JOHANSON INC., 400 Business Park Dr., Tyngsboro, MA 01879-1077 (978-649-3300; FAX: 978-649-3399)

Hoppers

HAPMAN, 6002 East N Avenue, Kalamazoo, MI 49048 (269-343-1675; FAX: 269-349-2477; sales@hapman.com; www.hapman.com)

JENIKE & JOHANSON INC., 400 Business Park Dr., Tyngsboro, MA 01879-1077 (978-649-3300; FAX: 978-649-3399)

ROSS MIXERS, 710 Old Willets Path, P.O. Box 12308, Hauppauge, NY 11788-0615 (631-234-0500; FAX: 631-234-0691; www.mixers.com)

Hoppers, weighing

HAPMAN, 6002 East N Avenue, Kalamazoo, MI 49048 (269-343-1675; FAX: 269-349-2477; sales@hapman.com; www.hapman.com)

SCHENCK PROCESS, 7901 NW 107th Terrace, Kansas City, MO 64153 (816-891-9300; FAX: 816-891-8336; www.schenckprocess.com)

Silos

JENIKE & JOHANSON INC., 400 Business Park Dr., Tyngsboro, MA 01879-1077 (978-649-3300; FAX: 978-649-3399)

BULK CARRIERS, LOADING & UNLOADING EQUIPMENT

Dumpers

MATERIAL TRANSFER & STORAGE INC., 1214 Lincoln Rd., P.O. Box 218, Allegan, MI 49010-0218 (269-673-2125; FAX: 269-673-4883; www.materialtransfer.com)

Loading arms

DYNATEK Loading Systems, North Prairie, WI

Unloaders, bulk bag

DYNAMIC AIR INC., 1125 Willow Lake Blvd., St. Paul, MN 55110-5193 (651-484-2900; FAX: 651-484-7015; www.dynamicair.com)

FLEXICON CORPORATION, 2400 Emrick Blvd., Bethlehem, PA 18020-8006 (610-814-2400; FAX: 610-814-0600)

MATERIAL TRANSFER & STORAGE INC., 1214 Lincoln Rd., P.O. Box 218, Allegan, MI 49010-0218 (269-673-2125; FAX: 269-673-4883; www.materialtransfer.com)

Palamatic Process Inc, PHILADELPHIA, PA

SCHENCK PROCESS, 7901 NW 107th Terrace, Kansas City, MO 64153 (816-891-9300; FAX: 816-891-8336; www.schenckprocess.com)

Unloaders, other

HAPMAN, 6002 East N Avenue, Kalamazoo, MI 49048 (269-343-1675; FAX: 269-349-2477; sales@hapman.com; www.hapman.com)

Unloaders, tank car

HAPMAN, 6002 East N Avenue, Kalamazoo, MI 49048 (269-343-1675; FAX: 269-349-2477; sales@hapman.com; www.hapman.com)

Unloaders, tank truck

HAPMAN, 6002 East N Avenue, Kalamazoo, MI 49048 (269-343-1675; FAX: 269-349-2477; sales@hapman.com; www.hapman.com)

COATING, FORMING & AGGLOMERATION EQUIPMENT

Agglomerators

JAYGO, INC., 7 Emery Ave., Randolph, NJ 07869 (908-688-3600; FAX: 908-688-6060)

Coaters & coating machinery

Gebrueder Loedige Maschinenbau GmbH, Paderborn, Germany

Extruders

PAUL O. ABBE, 201 Hanson Ct. Suite 125, Wood Dale, IL 60191 (630-350-3012; FAX: 630-238-7584)

—See our ad on page 15

JAYGO, INC., 7 Emery Ave., Randolph, NJ 07869 (908-688-3600; FAX: 908-688-6060)

Granulators & granulating mills

BERNDORF BAND GROUP, Leobersdorferstr. 26, Berndorf, Austria 2560 (43-2672-800-0; FAX: 43-2672-84176; www.berndorfband-group.com)

JAYGO, INC., 7 Emery Ave., Randolph, NJ 07869 (908-688-3600; FAX: 908-688-6060)

CONVEYORS & ELEVATORS FOR BULK MATERIALS

Chutes

JENIKE & JOHANSON INC., 400 Business Park Dr., Tyngsboro, MA 01879-1077 (978-649-3300; FAX: 978-649-3399)

Conveyor belting

BERNDORF BAND GROUP, Leobersdorferstr. 26, Berndorf, Austria 2560 (43-2672-800-0; FAX: 43-2672-84176; www.berndorfband-group.com)

Thayer Scale, Pembroke, MA

Conveyors, belt

BEUMER GROUP GMBH & CO. KG, Oelder Str. 40, Beckum, Germany 59269 (+49 2521 240; FAX: +49 2521 24280; www.beumergroup.com)

Thayer Scale, Pembroke, MA

Conveyors, bucket

BEUMER GROUP GMBH & CO. KG, Oelder Str. 40, Beckum, Germany 59269 (+49 2521 240; FAX: +49 2521 24280; www.beumergroup.com)

Conveyors, drag

HAPMAN, 6002 East N Avenue, Kalamazoo, MI 49048 (269-343-1675; FAX: 269-349-2477; sales@hapman.com; www.hapman.com)

Conveyors, flexible

HAPMAN, 6002 East N Avenue, Kalamazoo, MI 49048 (269-343-1675; FAX: 269-349-2477; sales@hapman.com; www.hapman.com)

Conveyors, flight

HAPMAN, 6002 East N Avenue, Kalamazoo, MI 49048 (269-343-1675; FAX: 269-349-2477; sales@hapman.com; www.hapman.com)

Conveyors, fluidizing

HAPMAN, 6002 East N Avenue, Kalamazoo, MI 49048 (269-343-1675; FAX: 269-349-2477; sales@hapman.com; www.hapman.com)

Conveyors, gravity

DYNAMIC AIR INC., 1125 Willow Lake Blvd., St. Paul, MN 55110-5193 (651-484-2900; FAX: 651-484-7015; www.dynamicair.com)

Conveyors, other

HAPMAN, 6002 East N Avenue, Kalamazoo, MI 49048 (269-343-1675; FAX: 269-349-2477; sales@hapman.com; www.hapman.com)

Conveyors, pneumatic

COPERION / COPERION K-TRON, 606 North Front Street, Salina, KS 67401 (785-825-1611; www.coperion.com)

DYNAMIC AIR INC., 1125 Willow Lake Blvd., St. Paul, MN 55110-5193 (651-484-2900; FAX: 651-484-7015; www.dynamicair.com)

FLEXICON CORPORATION, 2400 Emrick Blvd., Bethlehem, PA 18020-8006 (610-814-2400; FAX: 610-814-0600)

HAPMAN, 6002 East N Avenue, Kalamazoo, MI 49048 (269-343-1675; FAX: 269-349-2477; sales@hapman.com; www.hapman.com)

JENIKE & JOHANSON INC., 400 Business Park Dr., Tyngsboro, MA 01879-1077 (978-649-3300; FAX: 978-649-3399)

Palamatic Process Inc, PHILADELPHIA, PA

SCHENCK PROCESS, 7901 NW 107th Terrace, Kansas City, MO 64153 (816-891-9300; FAX: 816-891-8336; www.schenckprocess.com)

Thayer Scale, Pembroke, MA

Conveyors, portable

HAPMAN, 6002 East N Avenue, Kalamazoo, MI 49048 (269-343-1675; FAX: 269-349-2477; sales@hapman.com; www.hapman.com)

Conveyors, screw

FLEXICON CORPORATION, 2400 Emrick Blvd., Bethlehem, PA 18020-8006 (610-814-2400; FAX: 610-814-0600)

HAPMAN, 6002 East N Avenue, Kalamazoo, MI 49048 (269-343-1675; FAX: 269-349-2477; sales@hapman.com; www.hapman.com)

Palamatic Process Inc, PHILADELPHIA, PA

Conveyors, vacuum

CROLL REYNOLDS CO. INC., Six Campus Drive, Parsippany, NJ 07054 (908-232-4200; FAX: 908-232-2146; info@croll.com; www.croll.com)

HAPMAN, 6002 East N Avenue, Kalamazoo, MI 49048 (269-343-1675; FAX: 269-349-2477; sales@hapman.com; www.hapman.com)

Conveyors, vibrating

DYNAMIC AIR INC., 1125 Willow Lake Blvd., St. Paul, MN 55110-5193 (651-484-2900; FAX: 651-484-7015; www.dynamicair.com)

HAPMAN, 6002 East N Avenue, Kalamazoo, MI 49048 (269-343-1675; FAX: 269-349-2477; sales@hapman.com; www.hapman.com)

Conveyors, weighing

HAPMAN, 6002 East N Avenue, Kalamazoo, MI 49048 (269-343-1675; FAX: 269-349-2477; sales@hapman.com; www.hapman.com)

SIEMENS PROCESS INSTRUMENTATION, 2060 Detwiler Road, Suite 111, Harleysville, PA 19438 (800-365-8766; piabu-requestinformation.industry@siemens.com; www.usa.siemens.com/pablog)

Thayer Scale, Pembroke, MA

Couplings, pneumatic conveyors

HAPMAN, 6002 East N Avenue, Kalamazoo, MI 49048 (269-343-1675; FAX: 269-349-2477; sales@hapman.com; www.hapman.com)

SCHENCK PROCESS, 7901 NW 107th Terrace, Kansas City, MO 64153 (816-891-9300; FAX: 816-891-8336; www.schenckprocess.com)

Thayer Scale, Pembroke, MA

Solids feeders, airlock

SCHENCK PROCESS, 7901 NW 107th Terrace, Kansas City, MO 64153 (816-891-9300; FAX: 816-891-8336; www.schenckprocess.com)

Solids feeders, batch

JENIKE & JOHANSON INC., 400 Business Park Dr., Tyngsboro, MA 01879-1077 (978-649-3300; FAX: 978-649-3399)

SCHENCK PROCESS, 7901 NW 107th Terrace, Kansas City, MO 64153 (816-891-9300; FAX: 816-891-8336; www.schenckprocess.com)

SIEMENS PROCESS INSTRUMENTATION, 2060 Detwiler Road, Suite 111, Harleysville, PA 19438 (800-365-8766; piabu-requestinformation.industry@siemens.com; www.usa.siemens.com/pablog)

Solids feeders, continuous flow

JENIKE & JOHANSON INC., 400 Business Park Dr., Tyngsboro, MA 01879-1077 (978-649-3300; FAX: 978-649-3399)

SCHENCK PROCESS, 7901 NW 107th Terrace, Kansas City, MO 64153 (816-891-9300; FAX: 816-891-8336; www.schenckprocess.com)

Thayer Scale, Pembroke, MA

Solids feeders, gravimetric

COPERION / COPERION K-TRON, 606 North Front Street, Salina, KS 67401 (785-825-1611; www.coperion.com)

SCHENCK PROCESS, 7901 NW 107th Terrace, Kansas City, MO 64153 (816-891-9300; FAX: 816-891-8336; www.schenckprocess.com)

Thayer Scale, Pembroke, MA

Solids feeders, proportioning

SCHENCK PROCESS, 7901 NW 107th Terrace, Kansas City, MO 64153 (816-891-9300; FAX: 816-891-8336; www.schenckprocess.com)

Solids feeders, rotary

SCHENCK PROCESS, 7901 NW 107th Terrace, Kansas City, MO 64153 (816-891-9300; FAX: 816-891-8336; www.schenckprocess.com)

Solids feeders, vibrating or oscillating

DYNAMIC AIR INC., 1125 Willow Lake Blvd., St. Paul, MN 55110-5193 (651-484-2900; FAX: 651-484-7015; www.dynamicair.com)

SCHENCK PROCESS, 7901 NW 107th Terrace, Kansas City, MO 64153 (816-891-9300; FAX: 816-891-8336; www.schenckprocess.com)

Solids feeders, volumetric

COPERION / COPERION K-TRON, 606 North Front Street, Salina, KS 67401 (785-825-1611; www.coperion.com)

JENIKE & JOHANSON INC., 400 Business Park Dr., Tyngsboro, MA 01879-1077 (978-649-3300; FAX: 978-649-3399)

SCHENCK PROCESS, 7901 NW 107th Terrace, Kansas City, MO 64153 (816-891-9300; FAX: 816-891-8336; www.schenckprocess.com)

Thayer Scale, Pembroke, MA

LIFTING EQUIPMENT

Hoists

MATERIAL TRANSFER & STORAGE INC., 1214 Lincoln Rd., P.O. Box 218, Allegan, MI 49010-0218 (269-673-2125; FAX: 269-673-4883; www.materialtransfer.com)

PACKAGING EQUIPMENT

Bag filling machines

BEUMER GROUP GMBH & CO. KG, Oelder Str. 40, Beckum, Germany 59269 (+49 2521 240; FAX: +49 2521 24280; www.beumergroup.com)

MATERIAL TRANSFER & STORAGE INC., 1214 Lincoln Rd., P.O. Box 218, Allegan, MI 49010-0218 (269-673-2125; FAX: 269-673-4883; www.materialtransfer.com)

Bag, empty, handling systems

BEUMER GROUP GMBH & CO. KG, Oelder Str. 40, Beckum, Germany 59269 (+49 2521 240; FAX: +49 2521 24280; www.beumergroup.com)

DYNAMIC AIR INC., 1125 Willow Lake Blvd., St. Paul, MN 55110-5193 (651-484-2900; FAX: 651-484-7015; www.dynamicair.com)

Drum filling equipment

MATERIAL TRANSFER & STORAGE INC., 1214 Lincoln Rd., P.O. Box 218, Allegan, MI 49010-0218 (269-673-2125; FAX: 269-673-4883; www.materialtransfer.com)

Packaging equipment, solids

BEUMER GROUP GMBH & CO. KG, Oelder Str. 40, Beckum, Germany 59269 (+49 2521 240; FAX: +49 2521 24280; www.beumergroup.com)

Packers, bag

BEUMER GROUP GMBH & CO. KG, Oelder Str. 40, Beckum, Germany 59269 (+49 2521 240; FAX: +49 2521 24280; www.beumergroup.com)

SOLIDS HANDLING EQUIPMENT & SYSTEMS, OTHER

Barrel handling equipment

MATERIAL TRANSFER & STORAGE INC., 1214 Lincoln Rd., P.O. Box 218, Allegan, MI 49010-0218 (269-673-2125; FAX: 269-673-4883; www.materialtransfer.com)

Drum handling equipment

BENKO PRODUCTS, INC., 5350 Evergreen Pkwy., Sheffield Village, OH 44054 (440-934-2180; FAX: 440-934-4052; www.benkoproducts.com)

FLEXICON CORPORATION, 2400 Emrick Blvd., Bethlehem, PA 18020-8006 (610-814-2400; FAX: 610-814-0600)

MATERIAL TRANSFER & STORAGE INC., 1214 Lincoln Rd., P.O. Box 218, Allegan, MI 49010-0218 (269-673-2125; FAX: 269-673-4883; www.materialtransfer.com)

Materials handling systems

Acrison, Inc.

BEUMER GROUP GMBH & CO. KG, Oelder Str. 40, Beckum, Germany 59269 (+49 2521 240; FAX: +49 2521 24280; www.beumergroup.com)

COPERION / COPERION K-TRON, 606 North Front Street, Salina, KS 67401 (785-825-1611; www.coperion.com)

HAPMAN, 6002 East N Avenue, Kalamazoo, MI 49048 (269-343-1675; FAX: 269-349-2477; sales@hapman.com; www.hapman.com)

IPCO GERMANY GMBH, Salierstr. 35, Fellbach, Germany 70736 (+49 711 5105 0)

JENIKE & JOHANSON INC., 400 Business Park Dr., Tyngsboro, MA 01879-1077 (978-649-3300; FAX: 978-649-3399)

MATERIAL TRANSFER & STORAGE INC., 1214 Lincoln Rd., P.O. Box 218, Allegan, MI 49010-0218 (269-673-2125; FAX: 269-673-4883; www.materialtransfer.com)

SCHENCK PROCESS, 7901 NW 107th Terrace, Kansas City, MO 64153 (816-891-9300; FAX: 816-891-8336; www.schenckprocess.com)

Palletizers

BEUMER GROUP GMBH & CO. KG, Oelder Str. 40, Beckum, Germany 59269 (+49 2521 240; FAX: +49 2521 24280; www.beumergroup.com)

Robotic components

BEUMER GROUP GMBH & CO. KG, Oelder Str. 40, Beckum, Germany 59269 (+49 2521 240; FAX: +49 2521 24280; www.beumergroup.com)

Storage systems

BENKO PRODUCTS, INC., 5350 Evergreen Pkwy., Sheffield Village, OH 44054 (440-934-2180; FAX: 440-934-4052; www.benkoproducts.com)

BEUMER GROUP GMBH & CO. KG, Oelder Str. 40, Beckum, Germany 59269 (+49 2521 240; FAX: +49 2521 24280; www.beumergroup.com)

JENIKE & JOHANSON INC., 400 Business Park Dr., Tyngsboro, MA 01879-1077 (978-649-3300; FAX: 978-649-3399)

Valves, diverter conveyor

DYNAMIC AIR INC., 1125 Willow Lake Blvd., St. Paul, MN 55110-5193 (651-484-2900; FAX: 651-484-7015; www.dynamicair.com)

SCHENCK PROCESS, 7901 NW 107th Terrace, Kansas City, MO 64153 (816-891-9300; FAX: 816-891-8336; www.schenckprocess.com)

Valves, powder

SCHENCK PROCESS, 7901 NW 107th Terrace, Kansas City, MO 64153 (816-891-9300; FAX: 816-891-8336; www.schenckprocess.com)

WEIGHING, FEEDING & PROPORTIONING EQUIPMENT

Batching & blending systems

Acrison, Inc.

COPERION / COPERION K-TRON, 606 North Front Street, Salina, KS 67401 (785-825-1611; www.coperion.com)

DYNAMIC AIR INC., 1125 Willow Lake Blvd., St. Paul, MN 55110-5193 (651-484-2900; FAX: 651-484-7015; www.dynamicair.com)

FLEXICON CORPORATION, 2400 Emrick Blvd., Bethlehem, PA 18020-8006 (610-814-2400; FAX: 610-814-0600)

HAPMAN, 6002 East N Avenue, Kalamazoo, MI 49048 (269-343-1675; FAX: 269-349-2477; sales@hapman.com; www.hapman.com)

JENIKE & JOHANSON INC., 400 Business Park Dr., Tyngsboro, MA 01879-1077 (978-649-3300; FAX: 978-649-3399)

SIEMENS PROCESS INSTRUMENTATION, 2060 Detwiler Road, Suite 111, Harleysville, PA 19438 (800-365-8766; piabu-requestinformation.industry@siemens.com; www.usa.siemens.com/pablog)

Proportioners

Acrison, Inc.

Scales, checkweight

METTLER-TOLEDO, LLC, 1900 Polaris Pkwy., Columbus, OH 43240-4518 (1-800-METTLER; FAX: 614-438-4518)

SARTORIUS - CHEMICAL & CONSUMER CARE, Otto-Brenner-Straße 20, Goettingen, Germany 37079 (+49-(0)551 3084756; www.sartorius.com/chemicals)

Scales, continuous weighing

Acrison, Inc.

METTLER-TOLEDO, LLC, 1900 Polaris Pkwy., Columbus, OH 43240-4518 (1-800-METTLER; FAX: 614-438-4518)

SIEMENS PROCESS INSTRUMENTATION, 2060 Detwiler Road, Suite 111, Harleysville, PA 19438 (800-365-8766; piabu-requestinformation.industry@siemens.com; www.usa.siemens.com/pablog)

Thayer Scale, Pembroke, MA

Scales, conveying

SCHENCK PROCESS, 7901 NW 107th Terrace, Kansas City, MO 64153 (816-891-9300; FAX: 816-891-8336; www.schenckprocess.com)

SIEMENS PROCESS INSTRUMENTATION, 2060 Detwiler Road, Suite 111, Harleysville, PA 19438 (800-365-8766; piabu-requestinformation.industry@siemens.com; www.usa.siemens.com/pablog)

Thayer Scale, Pembroke, MA

Scales, counting

METTLER-TOLEDO, LLC, 1900 Polaris Pkwy., Columbus, OH 43240-4518 (1-800-METTLER; FAX: 614-438-4518)

Scales, floor, platform

METTLER-TOLEDO, LLC, 1900 Polaris Pkwy., Columbus, OH 43240-4518 (1-800-METTLER; FAX: 614-438-4518)

Scales, hopper

HAPMAN, 6002 East N Avenue, Kalamazoo, MI 49048 (269-343-1675; FAX: 269-349-2477; sales@hapman.com; www.hapman.com)

METTLER-TOLEDO, LLC, 1900 Polaris Pkwy., Columbus, OH 43240-4518 (1-800-METTLER; FAX: 614-438-4518)

Thayer Scale, Pembroke, MA

Scales, portable

METTLER-TOLEDO, LLC, 1900 Polaris Pkwy., Columbus, OH 43240-4518 (1-800-METTLER; FAX: 614-438-4518)

PCE Instruments UK Ltd, Southampton, Hampshire, United Kingdom

Scales, railroad car

METTLER-TOLEDO, LLC, 1900 Polaris Pkwy., Columbus, OH 43240-4518 (1-800-METTLER; FAX: 614-438-4518)

SCHENCK PROCESS, 7901 NW 107th Terrace, Kansas City, MO 64153 (816-891-9300; FAX: 816-891-8336; www.schenckprocess.com)

Scales, tank

METTLER-TOLEDO, LLC, 1900 Polaris Pkwy., Columbus, OH 43240-4518 (1-800-METTLER; FAX: 614-438-4518)

Scales, totalizing

SCHENCK PROCESS, 7901 NW 107th Terrace, Kansas City, MO 64153 (816-891-9300; FAX: 816-891-8336; www.schenckprocess.com)

Scales, truck

METTLER-TOLEDO, LLC, 1900 Polaris Pkwy., Columbus, OH 43240-4518 (1-800-METTLER; FAX: 614-438-4518)

Overpressure, Runaway Reactions and Explosions

Volume: 1 Understanding the Fundamentals

This Chemical Engineering guidebook contains dozens of practical, how-to engineering articles to better help you do your job. It addresses engineering challenges and solutions related to the prevention of overpressure situations, runaway reactions, plant upsets and potentially explosive operating conditions.

These tutorial-style articles focus on monitoring pressure in the chemical process environment, selecting and operating pressure-relief valves. Also provided are engineering recommendations for safely handling and storing reactive chemicals, and the design and operation of explosion-protection devices and systems.

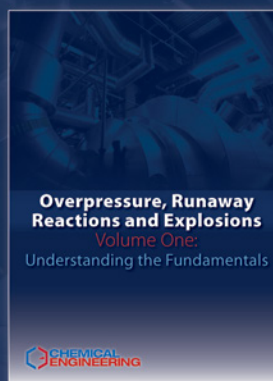

28019

Learn more at store.chemengonline.com



3

ELECTRICAL POWER GENERATION & TRANSMISSION

- 75 Associations**
- 75 Boilers, industrial**
- 75 Cable & conduit**
- 75 Drives, Other**
- 75 Drives, Turbine**
- 76 Electrical & power generation equipment**

- 76 Electrical heating equipment**
- 76 Lighting fixtures**
- 76 Motor controls**
- 76 Motors, electric**
- 76 Other electrical equipment**

ASSOCIATIONS

DECHEMA E.V., Theodor-Heuss-Allee 25, Frankfurt am Main, Germany 60486 (49-69-75-64-0; FAX: 49-69-75-64-201; www.dechema.de)
— See our ad on page 22

BOILERS, INDUSTRIAL

Boiler accessories

INDECK POWER EQUIPMENT CO., 1111 Willis Ave. (CE), Wheeling, IL 60090 (847-541-8300; FAX: 847-541-9984; www.indeck.com)
— See our ad on page 15

JOHN ZINK HAMWORTHY COMBUSTION, 11920 East Apache Street, Tulsa, OK 74116 (918-234-2800; FAX: 918-234-1800)

Wabash Power Equipment Co., Wheeling, IL

Boilers, automatic, packaged

INDECK POWER EQUIPMENT CO., 1111 Willis Ave. (CE), Wheeling, IL 60090 (847-541-8300; FAX: 847-541-9984; www.indeck.com)
— See our ad on page 15

Wabash Power Equipment Co., Wheeling, IL

Boilers, coal fired

INDECK POWER EQUIPMENT CO., 1111 Willis Ave. (CE), Wheeling, IL 60090 (847-541-8300; FAX: 847-541-9984; www.indeck.com)
— See our ad on page 15

Wabash Power Equipment Co., Wheeling, IL

Boilers, fire tube

INDECK POWER EQUIPMENT CO., 1111 Willis Ave. (CE), Wheeling, IL 60090 (847-541-8300; FAX: 847-541-9984; www.indeck.com)
— See our ad on page 15

Wabash Power Equipment Co., Wheeling, IL

Boilers, fluidized bed

Wabash Power Equipment Co., Wheeling, IL

Boilers, integral furnace

INDECK POWER EQUIPMENT CO., 1111 Willis Ave. (CE), Wheeling, IL 60090 (847-541-8300; FAX: 847-541-9984; www.indeck.com)
— See our ad on page 15

Boilers, natural gas fired

INDECK POWER EQUIPMENT CO., 1111 Willis Ave. (CE), Wheeling, IL 60090 (847-541-8300; FAX: 847-541-9984; www.indeck.com)
— See our ad on page 15

Boilers, oil fired

INDECK POWER EQUIPMENT CO., 1111 Willis Ave. (CE), Wheeling, IL 60090 (847-541-8300; FAX: 847-541-9984; www.indeck.com)
— See our ad on page 15

Boilers, waste heat recovery

CURTISS-WRIGHT EST GROUP, 2701 Township Line Rd., Hatfield, PA 19440 (215-721-1100; FAX: 215-721-1101)

INDECK POWER EQUIPMENT CO., 1111 Willis Ave. (CE), Wheeling, IL 60090 (847-541-8300; FAX: 847-541-9984; www.indeck.com)
— See our ad on page 15

Boilers, water tube

CLEAVER-BROOKS, INC., 221 Law Street, Thomasville, GA 6850731792 (229-226-3024; FAX: 800-250-5883; www.cleaverbrooks.com)

INDECK POWER EQUIPMENT CO., 1111 Willis Ave. (CE), Wheeling, IL 60090 (847-541-8300; FAX: 847-541-9984; www.indeck.com)
— See our ad on page 15

CABLE & CONDUIT

Wire & cable

ACS Industries Inc., Lincoln, RI

DRIVES, OTHER

Drives, gear

SEW-EURODRIVE PTE. LTD., Singapore

DRIVES, TURBINE

Turbines, combined steam-gas

MAN Energy Solutions SE, Oberhausen, Germany

Turbines, mechanical drive, gas

MAN Energy Solutions SE, Oberhausen, Germany

ADVERTISE IN THE CLASSIFIEDS

Contact your Sales Representative for More Information:

JASON BULLOCK | bullock@chemengonline.com
713-974-0911

TERRY DAVIS | tdavis@chemengonline.com
404-434-5123

PETRA TRAUTES | ptrautes@accessintel.com
+49 49 58604760

Turbines, mechanical drive, steam

MAN Energy Solutions SE, Oberhausen, Germany

ELECTRICAL & POWER GENERATION EQUIPMENT

Cogeneration systems & equipment

Waste-to-Energy, Salt Lake City, UT

Expanders

MAN Energy Solutions SE, Oberhausen, Germany

Generator-turbine sets

MAN Energy Solutions SE, Oberhausen, Germany

Generators, electrical

INDECK POWER EQUIPMENT CO., 1111 Willis Ave. (CE), Wheeling, IL 60090 (847-541-8300; FAX: 847-541-9984; www.indeck.com)
—See our ad on page 15

ELECTRICAL HEATING EQUIPMENT

Heaters, electric immersion

CAST-X Circulation Heaters, Batavia, IL

Heaters, thermal fluid electric

CAST-X Circulation Heaters, Batavia, IL
Mokon, Buffalo, NY
Water Heating Direct, Fort Worth, TX

LIGHTING FIXTURES

Lighting, explosion proof

R. STAHL, Waldenburg, Germany

MOTOR CONTROLS

Actuators or starters, motor

SEW-EURODRIVE PTE. LTD., Singapore

MOTORS, ELECTRIC

Motors, explosion proof

SEW-EURODRIVE PTE. LTD., Singapore

Motors, variable speed

SEW-EURODRIVE PTE. LTD., Singapore

OTHER ELECTRICAL EQUIPMENT

Circuit breakers

Phoenix Contact GmbH & Co.KG, Blomberg, Germany

Electrical equipment, other

Phoenix Contact GmbH & Co.KG, Blomberg, Germany

Switchgear & other power distribution equipment

Niagara Transformer Corp., Buffalo, NY

Transformers

Niagara Transformer Corp., Buffalo, NY

Transformers, isolation

Niagara Transformer Corp., Buffalo, NY



**Experience
POWER** 

The must attend event for 2022 covering the full energy value chain for the power industry.

SAVE THE DATE!
**October 3-6
2022**
Gaylord Rockies | Denver, CO
www.experience-power.com

The poster features a dark blue background with glowing white and green circular patterns and a network of blue lines. Two circular inset images show a group of people in a meeting and a busy trade show floor.

4

INSTRUMENTATION & CONTROLS

- | | | | |
|-----------|------------------------------------|-----------|---|
| 77 | Associations | 79 | Indicators |
| 77 | Actuators, operators | 80 | Measurement & testing equipment |
| 77 | Analyzers, offstream | 81 | Recorders |
| 78 | Analyzers, onstream | 81 | Transmitters & data transmission equipment |
| 78 | Computers, process control | | |
| 78 | Controllers | | |
| 79 | Data presentation equipment | | |

ASSOCIATIONS

DECHEMA e.V., Theodor-Heuss-Allee 25, Frankfurt am Main, Germany 60486 (49-69-75-64-0; FAX: 49-69-75-64-201; www.dechema.de)
— See our ad on page 22

ACTUATORS, OPERATORS

Actuators

ARCA Regler GmbH, Toennisvorst, Germany
AUMA RIESTER GMBH & CO. KG, Aumastrasse 1, Muellheim, Germany 79379 (+49 7631 8091250; www.auma.com)

Buerkert Fluid Control Systems, Ingelfingen, Germany
Metso Flow Control Inc, Vantaa, Finland

PLAST-O-MATIC VALVES INC., 1384 Pompton Ave., Cedar Grove, NJ 07009-1095 (973-256-3000; FAX: 973-256-4745)

— See our ad on page 33

POSI-FLATE, 1125 Willow Lake Blvd., St. Paul, MN 55110-5193 (651-484-5800; FAX: 651-484-7015; www.posiflate.com)

Valve operators, electrohydraulic

WELLAND & TUXHORN AG, Gütersloher Str. 257, Bielefeld, Germany 33649 (+49 521 9418-0; FAX: +49 521 9418-156; www.welland-tuxhorn.de)

Valve operators, electropneumatic

WELLAND & TUXHORN AG, Gütersloher Str. 257, Bielefeld, Germany 33649 (+49 521 9418-0; FAX: +49 521 9418-156; www.welland-tuxhorn.de)

Valve operators, piston

AUMA RIESTER GMBH & CO. KG, Aumastrasse 1, Muellheim, Germany 79379 (+49 7631 8091250; www.auma.com)

Valve operators, pneumatic

Buerkert Fluid Control Systems, Ingelfingen, Germany
POSI-FLATE, 1125 Willow Lake Blvd., St. Paul, MN 55110-5193 (651-484-5800; FAX: 651-484-7015; www.posiflate.com)

Valve positioners, microprocessor equipped

ARCA Regler GmbH, Toennisvorst, Germany
Metso Flow Control Inc, Vantaa, Finland

Valve, position indicators

GEMU Valves, Inc., Atlanta, GA

ANALYZERS, OFFSTREAM

Analyzers, carbon dioxide or monoxide

UIC INC., 1225 Channahon Rd., P.O. Box 863, Joliet, IL 60434-0863 (815-744-4477; FAX: 815-744-1561; warmstrong@uicinc.com; www.uicinc.com)

Analyzers, combustible gases

METTLER-TOLEDO PROCESS ANALYTICS, 900 Middlesex Turnpike, Building 8, Billerica, MA 01821 (800-352-8736; FAX: 781-301-8701)

Analyzers, concentration

AUTOMATION PRODUCTS INC. (DYNATROL DIV.), 3030 Maxroy St., Houston, TX 77008 (713-869-0361; FAX: 713-869-7332; sales@dynamatrolusa.com; www.dynamatrolusa.com)

Analyzers, conductivity

Krohne, Inc., Beverly, MA
METTLER-TOLEDO PROCESS ANALYTICS, 900 Middlesex Turnpike, Building 8, Billerica, MA 01821 (800-352-8736; FAX: 781-301-8701)

MYRON L COMPANY, 2450 Impala Drive, Carlsbad, CA 92010 (760-438-2021; FAX: 760-931-9189; www.myronl.com)

— See our ad on page 20

Analyzers, corrosion rate

PARR INSTRUMENT COMPANY, 211 53rd Street, Moline, IL 61265 (309-762-7716; FAX: 309-762-9453; lisa.randolph@parrinst.com; www.parrinst.com)

Analyzers, gas density

Pfeiffer Vacuum GmbH, Asslar, Germany
Pfeiffer Vacuum, Inc., Nashua, NH

Analyzers, hydrocarbons

AUTOMATION PRODUCTS INC. (DYNATROL DIV.), 3030 Maxroy St., Houston, TX 77008 (713-869-0361; FAX: 713-869-7332; sales@dynamatrolusa.com; www.dynamatrolusa.com)

Analyzers, mass spectrometer

Pfeiffer Vacuum GmbH, Asslar, Germany
Pfeiffer Vacuum, Inc., Nashua, NH

Analyzers, organic carbon

UIC INC., 1225 Channahon Rd., P.O. Box 863, Joliet, IL 60434-0863 (815-744-4477; FAX: 815-744-1561; warmstrong@uicinc.com; www.uicinc.com)

Analyzers, organic carbon, total

UIC INC., 1225 Channahon Rd., P.O. Box 863, Joliet, IL 60434-0863 (815-744-4477; FAX: 815-744-1561; warmstrong@uicinc.com; www.uicinc.com)

Analyzers, oxygen, dissolved

METTLER-TOLEDO PROCESS ANALYTICS, 900 Middlesex Turnpike, Building 8, Billerica, MA 01821 (800-352-8736; FAX: 781-301-8701)

Analyzers, particle size

FRITSCH GmbH - Milling and Sizing, Idar-Oberstein, Idar-Oberstein, Germany

Analyzers, pH

Krohne, Inc., Beverly, MA
MYRON L COMPANY, 2450 Impala Drive, Carlsbad, CA 92010 (760-438-2021; FAX: 760-931-9189; www.myronl.com)

— See our ad on page 20

Analyzers, spectrometer

Pfeiffer Vacuum, Inc., Nashua, NH

Analyzers, suspended solids

AUTOMATION PRODUCTS INC. (DYNATROL DIV.), 3030 Maxroy St., Houston, TX 77008 (713-869-0361; FAX: 713-869-7332; sales@dynamatrolusa.com; www.dynamatrolusa.com)

Analyzers, total solids

AUTOMATION PRODUCTS INC. (DYNATROL DIV.), 3030 Maxroy St., Houston, TX 77008 (713-869-0361; FAX: 713-869-7332; sales@dynamatrolusa.com; www.dynamatrolusa.com)

Analyzers, vapor pressure

PARR INSTRUMENT COMPANY, 211 53rd Street, Moline, IL 61265 (309-762-7716; FAX: 309-762-9453; lisa.randolph@parrinst.com; www.parrinst.com)

Analyzers, water quality

METTLER-TOLEDO PROCESS ANALYTICS, 900 Middlesex Turnpike, Building 8, Billerica, MA 01821 (800-352-8736; FAX: 781-301-8701)

MYRON L COMPANY, 2450 Impala Drive, Carlsbad, CA 92010 (760-438-2021; FAX: 760-931-9189; www.myronl.com)

— See our ad on page 20

Detectors, gases

SIERRA INSTRUMENTS, INC., 5 Harris Ct., Bldg. L, Monterey, CA 93940 (831-373-0200; FAX: 831-373-4402; info@sierrainstruments.com; www.sierrainstruments.com)

Detectors, sludge blanket level

AUTOMATION PRODUCTS INC. (DYNATROL DIV.), 3030 Maxroy St., Houston, TX 77008 (713-869-0361; FAX: 713-869-7332; sales@dynamatrolusa.com; www.dynamatrolusa.com)

Tek-Trol LLC, Crystal Lake, IL

Detectors, vibration

TLV CORPORATION, 13901 S. Lakes Dr., Charlotte, NC 28273 (704-597-9070; FAX: 704-583-1610; www.tlv.com)
—See our ad on page 65

Samplers, automatic

BIAR SAMPLING SYSTEMS, 2506 S. Philippe Ave., Gonzales, LA 70737 (225-647-4300; contact@biar.us; www.biar.us)

Samplers, gas, air

BIAR SAMPLING SYSTEMS, 2506 S. Philippe Ave., Gonzales, LA 70737 (225-647-4300; contact@biar.us; www.biar.us)

Samplers, liquid

BIAR SAMPLING SYSTEMS, 2506 S. Philippe Ave., Gonzales, LA 70737 (225-647-4300; contact@biar.us; www.biar.us)

SENTRY EQUIPMENT CORP, 966 Blue Ribbon Circle North, Oconomowoc, WI 53066 (262-567-7256; FAX: 262-567-4523)

ANALYZERS, ONSTREAM

Monitors, air quality

SICK, INC., 6900 West 110th Street, Bloomington, MN 55438 (800-325-7425; www.sick.com)

Monitors, combustible gases, or vapors

SICK, INC., 6900 West 110th Street, Bloomington, MN 55438 (800-325-7425; www.sick.com)

Monitors, conductivity

MYRON L COMPANY, 2450 Impala Drive, Carlsbad, CA 92010 (760-438-2021; FAX: 760-931-9189; www.myronl.com)
—See our ad on page 20

Monitors, dust

SICK, INC., 6900 West 110th Street, Bloomington, MN 55438 (800-325-7425; www.sick.com)

Monitors, emissions, continuous

AMETEK Land, Dronfield, United Kingdom
FCI-FLUID COMPONENTS INTERNATIONAL, 1755 La Costa Meadows Dr., San Marcos, CA 92078 (760-744-6950; FAX: 760-736-6250; eflow@fluidcomponents.com; www.fluidcomponents.com)
SICK, INC., 6900 West 110th Street, Bloomington, MN 55438 (800-325-7425; www.sick.com)
SIERRA INSTRUMENTS, INC., 5 Harris Ct., Bldg. L, Monterey, CA 93940 (831-373-0200; FAX: 831-373-4402; info@sierrainstruments.com; www.sierrainstruments.com)

Monitors, hydrocarbon content

SICK, INC., 6900 West 110th Street, Bloomington, MN 55438 (800-325-7425; www.sick.com)

Monitors, opacity

AMETEK Land, Dronfield, United Kingdom
SICK, INC., 6900 West 110th Street, Bloomington, MN 55438 (800-325-7425; www.sick.com)

Monitors, oxygen content

SICK, INC., 6900 West 110th Street, Bloomington, MN 55438 (800-325-7425; www.sick.com)

Monitors, particle size

SICK, INC., 6900 West 110th Street, Bloomington, MN 55438 (800-325-7425; www.sick.com)

Monitors, stack gases

AMETEK Land, Dronfield, United Kingdom
FCI-FLUID COMPONENTS INTERNATIONAL, 1755 La Costa Meadows Dr., San Marcos, CA 92078 (760-744-6950; FAX: 760-736-6250; eflow@fluidcomponents.com; www.fluidcomponents.com)
SICK, INC., 6900 West 110th Street, Bloomington, MN 55438 (800-325-7425; www.sick.com)

Monitors, viscosity

AUTOMATION PRODUCTS INC. (DYNATROL DIV.), 3030 Maxroy St., Houston, TX 77008 (713-869-0361; FAX: 713-869-7332; sales@dynamtrolusa.com; www.dynamtrolusa.com)
LOAD CONTROLS, INC., 53 Technology Park Rd., Sturbridge, MA 01566 (508-347-2606; FAX: 508-347-2064)
—See our ad on page 12

Monitors, water quality

MYRON L COMPANY, 2450 Impala Drive, Carlsbad, CA 92010 (760-438-2021; FAX: 760-931-9189; www.myronl.com)
—See our ad on page 20

Spectrometers

Pfeiffer Vacuum, Inc., Nashua, NH

COMPUTERS, PROCESS CONTROL

Analog process control computers

ABB INC., 3700 West Sam Houston Parkway South, Houston, TX 77042 (1-800-HELP-365; FAX: 440-585-7071; contact.center@us.abb.com; www.abb.com/chemical)

Direct digital process control computers

ABB INC., 3700 West Sam Houston Parkway South, Houston, TX 77042 (1-800-HELP-365; FAX: 440-585-7071; contact.center@us.abb.com; www.abb.com/chemical)

EMERSON, 1100 W. Louis Henna Blvd. Building One, Round Rock, TX 78681 - 74 (800-833-8314)

Hybrid process control computers

ABB INC., 3700 West Sam Houston Parkway South, Houston, TX 77042 (1-800-HELP-365; FAX: 440-585-7071; contact.center@us.abb.com; www.abb.com/chemical)

Input-output equipment

ABB INC., 3700 West Sam Houston Parkway South, Houston, TX 77042 (1-800-HELP-365; FAX: 440-585-7071; contact.center@us.abb.com; www.abb.com/chemical)
EMERSON, 1100 W. Louis Henna Blvd. Building One, Round Rock, TX 78681 - 74 (800-833-8314)
PEPPERL+FUCHS SE, Lilienthalstrasse 200, Mannheim, Germany 68307 (+49-621-776-0; FAX: +49-621-776-1000; www.pepperl-fuchs.com)
R. STAHL, Waldenburger, Germany

Supervisory process control computers

ABB INC., 3700 West Sam Houston Parkway South, Houston, TX 77042 (1-800-HELP-365; FAX: 440-585-7071; contact.center@us.abb.com; www.abb.com/chemical)

CONTROLLERS

Controllers, air conditioning

ABB INC., 3700 West Sam Houston Parkway South, Houston, TX 77042 (1-800-HELP-365; FAX: 440-585-7071; contact.center@us.abb.com; www.abb.com/chemical)

Controllers, batching or weighing

SIEMENS PROCESS INSTRUMENTATION, 2060 Detwiler Road, Suite 111, Harleysville, PA 19438 (800-365-8766; piabu-requestinformation.industry@siemens.com; www.usa.siemens.com/pablog)

Controllers, bin level

AUTOMATION PRODUCTS INC. (DYNATROL DIV.), 3030 Maxroy St., Houston, TX 77008 (713-869-0361; FAX: 713-869-7332; sales@dynamtrolusa.com; www.dynamtrolusa.com)

Controllers, boiler

ABB INC., 3700 West Sam Houston Parkway South, Houston, TX 77042 (1-800-HELP-365; FAX: 440-585-7071; contact.center@us.abb.com; www.abb.com/chemical)
INDECK POWER EQUIPMENT CO., 1111 Willis Ave. (CE), Wheeling, IL 60090 (847-541-8300; FAX: 847-541-9984; www.indeck.com)
—See our ad on page 15

Controllers, combustion

ABB INC., 3700 West Sam Houston Parkway South, Houston, TX 77042 (1-800-HELP-365; FAX: 440-585-7071; contact.center@us.abb.com; www.abb.com/chemical)
INDECK POWER EQUIPMENT CO., 1111 Willis Ave. (CE), Wheeling, IL 60090 (847-541-8300; FAX: 847-541-9984; www.indeck.com)
—See our ad on page 15

UNIFLUX / EXOTHERM CORP., 31369 Nichols Sawmill Road, Magnolia, TX 77355 (713-981-9100; FAX: 713-981-7081; info@exotherm.com; www.exotherm.com)
—See our ad on page 57

Controllers, electric

ABB INC., 3700 West Sam Houston Parkway South, Houston, TX 77042 (1-800-HELP-365; FAX: 440-585-7071; contact.center@us.abb.com; www.abb.com/chemical)
SEW-EURODRIVE PTE. LTD., Singapore

Controllers, flow & flow ratio

ABB INC., 3700 West Sam Houston Parkway South, Houston, TX 77042 (1-800-HELP-365; FAX: 440-585-7071; contact.center@us.abb.com; www.abb.com/chemical)
BRONKHORST HIGH-TECH BV, Nijverheidsstraat 1A, Ruurlo, Netherlands NL-7261AK (+31 573458800; www.bronkhorst.com)
Buerkert Fluid Control Systems, Ingelfingen, Germany
FCI-FLUID COMPONENTS INTERNATIONAL, 1755 La Costa Meadows Dr., San Marcos, CA 92078 (760-744-6950; FAX: 760-736-6250; eflow@fluidcomponents.com; www.fluidcomponents.com)
PLAST-O-MATIC VALVES INC., 1384 Pompton Ave., Cedar Grove, NJ 07009-1095 (973-256-3000; FAX: 973-256-4745)
—See our ad on page 33
SIEMENS PROCESS INSTRUMENTATION, 2060 Detwiler Road, Suite 111, Harleysville, PA 19438 (800-365-8766; piabu-requestinformation.industry@siemens.com; www.usa.siemens.com/pablog)
SIERRA INSTRUMENTS, INC., 5 Harris Ct., Bldg. L, Monterey, CA 93940 (831-373-0200; FAX: 831-373-4402; info@sierrainstruments.com; www.sierrainstruments.com)

Controllers, hydraulic

ABB INC., 3700 West Sam Houston Parkway South, Houston, TX 77042 (1-800-HELP-365; FAX: 440-585-7071; contact.center@us.abb.com; www.abb.com/chemical)

Controllers, liquid level

ABB INC., 3700 West Sam Houston Parkway South, Houston, TX 77042 (1-800-HELP-365; FAX: 440-585-7071; contact.center@us.abb.com; www.abb.com/chemical)
AUTOMATION PRODUCTS INC. (DYNATROL DIV.), 3030 Maxroy St., Houston, TX 77008 (713-869-0361; FAX: 713-869-7332; sales@dynamtrolusa.com; www.dynamtrolusa.com)
FCI-FLUID COMPONENTS INTERNATIONAL, 1755 La Costa Meadows Dr., San Marcos, CA 92078 (760-744-6950; FAX: 760-736-6250; eflow@fluidcomponents.com; www.fluidcomponents.com)
SIEMENS PROCESS INSTRUMENTATION, 2060 Detwiler Road, Suite 111, Harleysville, PA 19438 (800-365-8766; piabu-requestinformation.industry@siemens.com; www.usa.siemens.com/pablog)
SIERRA INSTRUMENTS, INC., 5 Harris Ct., Bldg. L, Monterey, CA 93940 (831-373-0200; FAX: 831-373-4402; info@sierrainstruments.com; www.sierrainstruments.com)

Controllers, pneumatic

ABB INC., 3700 West Sam Houston Parkway South, Houston, TX 77042 (1-800-HELP-365; FAX: 440-585-7071; contact.center@us.abb.com; www.abb.com/chemical)
CASHCO, INC., P.O. Box 6, 607 W. 15th, Ellsworth, KS 67439-0006 (785-472-4461; FAX: 785-472-3539; www.cashco.com)

Controllers, pressure

ABB INC., 3700 West Sam Houston Parkway South, Houston, TX 77042 (1-800-HELP-365; FAX: 440-585-7071; contact.center@us.abb.com; www.abb.com/chemical)
BRONKHORST HIGH-TECH BV, Nijverheidsstraat 1A, Ruurlo, Netherlands NL-7261AK (+31 573458800; www.bronkhorst.com)
CASHCO, INC., P.O. Box 6, 607 W. 15th, Ellsworth, KS 67439-0006 (785-472-4461; FAX: 785-472-3539; www.cashco.com)

PLAST-O-MATIC VALVES INC., 1384 Pompton Ave., Cedar Grove, NJ 07009-1095 (973-256-3000; FAX: 973-256-4745)

—See our ad on page 33

SIEMENS PROCESS INSTRUMENTATION, 2060 Detwiler Road, Suite 111, Harleysville, PA 19438 (800-365-8766; piabu-requestinformation.industry@siemens.com; www.usa.siemens.com/pablog)

Strobic Air Technologies, Lansdale, PA

TLV CORPORATION, 13901 S. Lakes Dr., Charlotte, NC 28273 (704-597-9070; FAX: 704-583-1610; www.tlv.com)

—See our ad on page 65

Controllers, process

ABB INC., 3700 West Sam Houston Parkway South, Houston, TX 77042 (1-800-HELP-365; FAX: 440-585-7071; contact.center@us.abb.com; www.abb.com/chemical)

AUTOMATION PRODUCTS INC. (DYNATROL DIV.), 3030 Maxroy St., Houston, TX 77008 (713-869-0361; FAX: 713-869-7332; sales@dynatrolusa.com; www.dynatrolusa.com)

EMERSON, 1100 W. Louis Henna Blvd. Building One, Round Rock, TX 78681 - 74 (800-833-8314)

SIEMENS PROCESS INSTRUMENTATION, 2060 Detwiler Road, Suite 111, Harleysville, PA 19438 (800-365-8766; piabu-requestinformation.industry@siemens.com; www.usa.siemens.com/pablog)

SIERRA INSTRUMENTS, INC., 5 Harris Ct., Bldg. L, Monterey, CA 93940 (831-373-0200; FAX: 831-373-4402; info@sierrainstruments.com; www.sierrainstruments.com)

Controllers, programmable

Phoenix Contact GmbH & Co.KG, Blomberg, Germany

SIEMENS PROCESS INSTRUMENTATION, 2060 Detwiler Road, Suite 111, Harleysville, PA 19438 (800-365-8766; piabu-requestinformation.industry@siemens.com; www.usa.siemens.com/pablog)

Tek-Trol LLC, Crystal Lake, IL

Controllers, pump

BRONKHORST HIGH-TECH BV, Nijverheidsstraat 1A, Ruurlo, Netherlands NL-7261AK (+31 573458800; www.bronkhorst.com)

KNF NEUBERGER, INC., 2 Black Forest Rd., Trenton, NJ 08691-1810 (609-890-8600; knfusa@knf.com; www.knfusa.com)

Pfeiffer Vacuum, Inc., Nashua, NH

Controllers, sludge level

AUTOMATION PRODUCTS INC. (DYNATROL DIV.), 3030 Maxroy St., Houston, TX 77008 (713-869-0361; FAX: 713-869-7332; sales@dynatrolusa.com; www.dynatrolusa.com)

Controllers, temperature

ABB INC., 3700 West Sam Houston Parkway South, Houston, TX 77042 (1-800-HELP-365; FAX: 440-585-7071; contact.center@us.abb.com; www.abb.com/chemical)

CASHCO, INC., P.O. Box 6, 607 W. 15th, Ellsworth, KS 67439-0006 (785-472-4461; FAX: 785-472-3539; www.cashco.com)

HONEYWELL PROCESS SOLUTIONS, 1250 W Sam Houston Pkwy S, Houston, TX 77042 (832-252-3500; www.honeywellprocess.com)

LAUDA DR. R. WOBSEER GMBH & CO. KG, Lauda-Koenigschhofen, Germany
Mokon, Buffalo, NY

SIEMENS PROCESS INSTRUMENTATION, 2060 Detwiler Road, Suite 111, Harleysville, PA 19438 (800-365-8766; piabu-requestinformation.industry@siemens.com; www.usa.siemens.com/pablog)

Controllers, vacuum

PLAST-O-MATIC VALVES INC., 1384 Pompton Ave., Cedar Grove, NJ 07009-1095 (973-256-3000; FAX: 973-256-4745)

—See our ad on page 33

VACUUBRAND, INC., 11 Bokum Rd., Essex, CT 06426 (860-767-5341; www.vacuubrand.com)

Controllers, viscosity

AUTOMATION PRODUCTS INC. (DYNATROL DIV.), 3030 Maxroy St., Houston, TX 77008 (713-869-0361; FAX: 713-869-7332; sales@dynatrolusa.com; www.dynatrolusa.com)

Regulators, air

TLV CORPORATION, 13901 S. Lakes Dr., Charlotte, NC 28273 (704-597-9070; FAX: 704-583-1610; www.tlv.com)

—See our ad on page 65

Regulators, back pressure

CASHCO, INC., P.O. Box 6, 607 W. 15th, Ellsworth, KS 67439-0006 (785-472-4461; FAX: 785-472-3539; www.cashco.com)

FLUID LINE PRODUCTS INC., 38273 Western Pkwy., P.O. Box 1000, Willoughby, OH 44096 (440-946-9470; FAX: 440-946-9472; www.fluidline.com)

PLAST-O-MATIC VALVES INC., 1384 Pompton Ave., Cedar Grove, NJ 07009-1095 (973-256-3000; FAX: 973-256-4745)

—See our ad on page 33

TLV CORPORATION, 13901 S. Lakes Dr., Charlotte, NC 28273 (704-597-9070; FAX: 704-583-1610; www.tlv.com)

—See our ad on page 65

Regulators, flow

BRONKHORST HIGH-TECH BV, Nijverheidsstraat 1A, Ruurlo, Netherlands NL-7261AK (+31 573458800; www.bronkhorst.com)

FLUID LINE PRODUCTS INC., 38273 Western Pkwy., P.O. Box 1000, Willoughby, OH 44096 (440-946-9470; FAX: 440-946-9472; www.fluidline.com)

PLAST-O-MATIC VALVES INC., 1384 Pompton Ave., Cedar Grove, NJ 07009-1095 (973-256-3000; FAX: 973-256-4745)

—See our ad on page 33

Regulators, pressure

CASHCO, INC., P.O. Box 6, 607 W. 15th, Ellsworth, KS 67439-0006 (785-472-4461; FAX: 785-472-3539; www.cashco.com)

FLUID LINE PRODUCTS INC., 38273 Western Pkwy., P.O. Box 1000, Willoughby, OH 44096 (440-946-9470; FAX: 440-946-9472; www.fluidline.com)

PLAST-O-MATIC VALVES INC., 1384 Pompton Ave., Cedar Grove, NJ 07009-1095 (973-256-3000; FAX: 973-256-4745)

—See our ad on page 33

TLV CORPORATION, 13901 S. Lakes Dr., Charlotte, NC 28273 (704-597-9070; FAX: 704-583-1610; www.tlv.com)

—See our ad on page 65

Regulators, temperature

TLV CORPORATION, 13901 S. Lakes Dr., Charlotte, NC 28273 (704-597-9070; FAX: 704-583-1610; www.tlv.com)

—See our ad on page 65

Regulators, vacuum

TLV CORPORATION, 13901 S. Lakes Dr., Charlotte, NC 28273 (704-597-9070; FAX: 704-583-1610; www.tlv.com)

—See our ad on page 65

DATA PRESENTATION EQUIPMENT

Data logging systems

ABB INC., 3700 West Sam Houston Parkway South, Houston, TX 77042 (1-800-HELP-365; FAX: 440-585-7071; contact.center@us.abb.com; www.abb.com/chemical)

INDICATORS

Alarms, combustion

HONEYWELL PROCESS SOLUTIONS, 1250 W Sam Houston Pkwy S, Houston, TX 77042 (832-252-3500; www.honeywellprocess.com)

Alarms, flame

HONEYWELL PROCESS SOLUTIONS, 1250 W Sam Houston Pkwy S, Houston, TX 77042 (832-252-3500; www.honeywellprocess.com)

Alarms, flow

FCI-FLUID COMPONENTS INTERNATIONAL, 1755 La Costa Meadows Dr., San Marcos, CA 92078 (760-744-6950; FAX: 760-736-6250; eflow@fluidcomponents.com; www.fluidcomponents.com)

HONEYWELL PROCESS SOLUTIONS, 1250 W Sam Houston Pkwy S, Houston, TX 77042 (832-252-3500; www.honeywellprocess.com)

UNIVERSAL FLOW MONITORS, INC., 1755 E. Nine Mile Rd., Hazel Park, MI 48030 (248-542-9635; FAX: 248-398-4274; ufmsales@flowmeters.com; www.flowmeters.com/products)

Alarms, liquid level

FCI-FLUID COMPONENTS INTERNATIONAL, 1755 La Costa Meadows Dr., San Marcos, CA 92078 (760-744-6950; FAX: 760-736-6250; eflow@fluidcomponents.com; www.fluidcomponents.com)

HONEYWELL PROCESS SOLUTIONS, 1250 W Sam Houston Pkwy S, Houston, TX 77042 (832-252-3500; www.honeywellprocess.com)

Alarms, temperature

FCI-FLUID COMPONENTS INTERNATIONAL, 1755 La Costa Meadows Dr., San Marcos, CA 92078 (760-744-6950; FAX: 760-736-6250; eflow@fluidcomponents.com; www.fluidcomponents.com)

Flowmeters, differential pressure

AIR MONITOR CORPORATION, 1050 Hopper Ave., Santa Rosa, CA 95403 (1-800-AIRFLOW; FAX: 707-526-9970; www.airmonitor.com)

Badger Meter, Inc., Milwaukee, WI

Tek-Trol LLC, Crystal Lake, IL

UNIVERSAL FLOW MONITORS, INC., 1755 E. Nine Mile Rd., Hazel Park, MI 48030 (248-542-9635; FAX: 248-398-4274; ufmsales@flowmeters.com; www.flowmeters.com/products)

Flowmeters, electromagnetic

Krohne, Inc., Beverly, MA

SIEMENS PROCESS INSTRUMENTATION, 2060 Detwiler Road, Suite 111, Harleysville, PA 19438 (800-365-8766; piabu-requestinformation.industry@siemens.com; www.usa.siemens.com/pablog)

Tek-Trol LLC, Crystal Lake, IL

UNIVERSAL FLOW MONITORS, INC., 1755 E. Nine Mile Rd., Hazel Park, MI 48030 (248-542-9635; FAX: 248-398-4274; ufmsales@flowmeters.com; www.flowmeters.com/products)

Flowmeters, magnetic

Buerkert Fluid Control Systems, Ingelfingen, Germany

ENDRESS & HAUSER INC, 2350 Endress Place, Greenwood, IN 46143 (317-535-7138; FAX: 317-535-8498; www.endress.com)

SIEMENS PROCESS INSTRUMENTATION, 2060 Detwiler Road, Suite 111, Harleysville, PA 19438 (800-365-8766; piabu-requestinformation.industry@siemens.com; www.usa.siemens.com/pablog)

Flowmeters, mass

BRONKHORST HIGH-TECH BV, Nijverheidsstraat 1A, Ruurlo, Netherlands NL-7261AK (+31 573458800; www.bronkhorst.com)

ENDRESS & HAUSER INC, 2350 Endress Place, Greenwood, IN 46143 (317-535-7138; FAX: 317-535-8498; www.endress.com)

FCI-FLUID COMPONENTS INTERNATIONAL, 1755 La Costa Meadows Dr., San Marcos, CA 92078 (760-744-6950; FAX: 760-736-6250; eflow@fluidcomponents.com; www.fluidcomponents.com)

Krohne, Inc., Beverly, MA

SIEMENS PROCESS INSTRUMENTATION, 2060 Detwiler Road, Suite 111, Harleysville, PA 19438 (800-365-8766; piabu-requestinformation.industry@siemens.com; www.usa.siemens.com/pablog)

SIERRA INSTRUMENTS, INC., 5 Harris Ct., Bldg. L, Monterey, CA 93940 (831-373-0200; FAX: 831-373-4402; info@sierrainstruments.com; www.sierrainstruments.com)

Flowmeters, positive displacement

Badger Meter, Inc., Milwaukee, WI

BLUE-WHITE INDUSTRIES, 5300 Business Drive, Huntington Beach, CA 92649 (714-893-8529; FAX: 714-895-9492; sales@blue-white.com; www.blue-white.com)

Flowmeters, rotameters

BLUE-WHITE INDUSTRIES, 5300 Business Drive, Huntington Beach, CA 92649 (714-893-8529; FAX: 714-895-9492; sales@blue-white.com; www.blue-white.com)

UNIVERSAL FLOW MONITORS, INC., 1755 E. Nine Mile Rd., Hazel Park, MI 48030 (248-542-9635; FAX: 248-398-4274; ufmsales@flowmeters.com; www.flowmeters.com/products)

Flowmeters, turbine

Badger Meter, Inc., Milwaukee, WI

UNIVERSAL FLOW MONITORS, INC., 1755 E. Nine Mile Rd., Hazel Park, MI 48030 (248-542-9635; FAX: 248-398-4274; ufmsales@flowmeters.com; www.flowmeters.com/products)

Flowmeters, ultrasonic

BLUE-WHITE INDUSTRIES, 5300 Business Drive, Huntington Beach, CA 92649 (714-893-8529; FAX: 714-895-9492; sales@blue-white.com; www.blue-white.com)

BRONKHORST HIGH-TECH BV, Nijverheidsstraat 1A, Ruurlo, Netherlands NL-7261AK (+31 573458800; www.bronkhorst.com)
 Krohne, Inc., Beverly, MA
 PCE Instruments UK Ltd, Southampton, Hampshire, United Kingdom
SICK, INC., 6900 West 110th Street, Bloomington, MN 55438 (800-325-7425; www.sick.com)
SIEMENS PROCESS INSTRUMENTATION, 2060 Detwiler Road, Suite 111, Harleysville, PA 19438 (800-365-8766; piabu-request@information.industry@siemens.com; www.usa.siemens.com/pablog)
SIERRA INSTRUMENTS, INC., 5 Harris Ct., Bldg. L, Monterey, CA 93940 (831-373-0200; FAX: 831-373-4402; info@sierrainstruments.com; www.sierrainstruments.com)

Flowmeters, variable area

BLUE-WHITE INDUSTRIES, 5300 Business Drive, Huntington Beach, CA 92649 (714-893-8529; FAX: 714-895-9492; sales@blue-white.com; www.blue-white.com)
 GEMU Valves, Inc., Atlanta, GA
UNIVERSAL FLOW MONITORS, INC., 1755 E. Nine Mile Rd., Hazel Park, MI 48030 (248-542-9635; FAX: 248-398-4274; ufmsales@flowmeters.com; www.flowmeters.com/products)

Flowmeters, vortex shedding

SIERRA INSTRUMENTS, INC., 5 Harris Ct., Bldg. L, Monterey, CA 93940 (831-373-0200; FAX: 831-373-4402; info@sierrainstruments.com; www.sierrainstruments.com)
UNIVERSAL FLOW MONITORS, INC., 1755 E. Nine Mile Rd., Hazel Park, MI 48030 (248-542-9635; FAX: 248-398-4274; ufmsales@flowmeters.com; www.flowmeters.com/products)

Gages, liquid level

FCI-FLUID COMPONENTS INTERNATIONAL, 1755 La Costa Meadows Dr., San Marcos, CA 92078 (760-744-6950; FAX: 760-736-6250; eflow@fluidcomponents.com; www.fluidcomponents.com)
VEGA AMERICAS, INC., 4170 Rosslyn Drive, Cincinnati, OH 45209 (513-272-0131; FAX: 513-272-0133; www.vega.com)
VEGA GRIESHABER KG, Am Hohenstein 113, Schiltach, Germany, Germany 77761 (+49 7836 50-0; www.vega.com)

Gages, pressure

PCE Instruments UK Ltd, Southampton, Hampshire, United Kingdom
PLAST-O-MATIC VALVES INC., 1384 Pompton Ave., Cedar Grove, NJ 07009-1095 (973-256-3000; FAX: 973-256-4745)
 —See our ad on page 33
VEGA AMERICAS, INC., 4170 Rosslyn Drive, Cincinnati, OH 45209 (513-272-0131; FAX: 513-272-0133; www.vega.com)
VEGA GRIESHABER KG, Am Hohenstein 113, Schiltach, Germany, Germany 77761 (+49 7836 50-0; www.vega.com)

Gages, tank

VEGA AMERICAS, INC., 4170 Rosslyn Drive, Cincinnati, OH 45209 (513-272-0131; FAX: 513-272-0133; www.vega.com)
VEGA GRIESHABER KG, Am Hohenstein 113, Schiltach, Germany, Germany 77761 (+49 7836 50-0; www.vega.com)

Gages, vacuum & differential pressure

VACUUBRAND, INC., 11 Bokum Rd., Essex, CT 06426 (860-767-5341; www.vacuubrand.com)
VEGA AMERICAS, INC., 4170 Rosslyn Drive, Cincinnati, OH 45209 (513-272-0131; FAX: 513-272-0133; www.vega.com)
VEGA GRIESHABER KG, Am Hohenstein 113, Schiltach, Germany, Germany 77761 (+49 7836 50-0; www.vega.com)

Gages, water

VEGA AMERICAS, INC., 4170 Rosslyn Drive, Cincinnati, OH 45209 (513-272-0131; FAX: 513-272-0133; www.vega.com)
VEGA GRIESHABER KG, Am Hohenstein 113, Schiltach, Germany, Germany 77761 (+49 7836 50-0; www.vega.com)

Glasses, sight flow

PLAST-O-MATIC VALVES INC., 1384 Pompton Ave., Cedar Grove, NJ 07009-1095 (973-256-3000; FAX: 973-256-4745)
 —See our ad on page 33

Indicators, bin level

AUTOMATION PRODUCTS INC. (DYNATROL DIV.), 3030 Maxroy St., Houston, TX 77008 (713-869-0361; FAX: 713-869-7332; sales@dynamtrolusa.com; www.dynamtrolusa.com)
ENDRESS & HAUSER INC, 2350 Endress Place, Greenwood, IN 46143 (317-535-7138; FAX: 317-535-8498; www.endress.com)
VEGA AMERICAS, INC., 4170 Rosslyn Drive, Cincinnati, OH 45209 (513-272-0131; FAX: 513-272-0133; www.vega.com)
VEGA GRIESHABER KG, Am Hohenstein 113, Schiltach, Germany, Germany 77761 (+49 7836 50-0; www.vega.com)

Indicators, flow

Badger Meter, Inc., Milwaukee, WI
BLUE-WHITE INDUSTRIES, 5300 Business Drive, Huntington Beach, CA 92649 (714-893-8529; FAX: 714-895-9492; sales@blue-white.com; www.blue-white.com)
BRONKHORST HIGH-TECH BV, Nijverheidsstraat 1A, Ruurlo, Netherlands NL-7261AK (+31 573458800; www.bronkhorst.com)
FCI-FLUID COMPONENTS INTERNATIONAL, 1755 La Costa Meadows Dr., San Marcos, CA 92078 (760-744-6950; FAX: 760-736-6250; eflow@fluidcomponents.com; www.fluidcomponents.com)
PLAST-O-MATIC VALVES INC., 1384 Pompton Ave., Cedar Grove, NJ 07009-1095 (973-256-3000; FAX: 973-256-4745)
 —See our ad on page 33
SIERRA INSTRUMENTS, INC., 5 Harris Ct., Bldg. L, Monterey, CA 93940 (831-373-0200; FAX: 831-373-4402; info@sierrainstruments.com; www.sierrainstruments.com)
 Tek-Trol LLC, Crystal Lake, IL
UNIVERSAL FLOW MONITORS, INC., 1755 E. Nine Mile Rd., Hazel Park, MI 48030 (248-542-9635; FAX: 248-398-4274; ufmsales@flowmeters.com; www.flowmeters.com/products)

Indicators, liquid level

AUTOMATION PRODUCTS INC. (DYNATROL DIV.), 3030 Maxroy St., Houston, TX 77008 (713-869-0361; FAX: 713-869-7332; sales@dynamtrolusa.com; www.dynamtrolusa.com)
ENDRESS & HAUSER INC, 2350 Endress Place, Greenwood, IN 46143 (317-535-7138; FAX: 317-535-8498; www.endress.com)
FCI-FLUID COMPONENTS INTERNATIONAL, 1755 La Costa Meadows Dr., San Marcos, CA 92078 (760-744-6950; FAX: 760-736-6250; eflow@fluidcomponents.com; www.fluidcomponents.com)
PLAST-O-MATIC VALVES INC., 1384 Pompton Ave., Cedar Grove, NJ 07009-1095 (973-256-3000; FAX: 973-256-4745)
 —See our ad on page 33
SIERRA INSTRUMENTS, INC., 5 Harris Ct., Bldg. L, Monterey, CA 93940 (831-373-0200; FAX: 831-373-4402; info@sierrainstruments.com; www.sierrainstruments.com)
VEGA AMERICAS, INC., 4170 Rosslyn Drive, Cincinnati, OH 45209 (513-272-0131; FAX: 513-272-0133; www.vega.com)
VEGA GRIESHABER KG, Am Hohenstein 113, Schiltach, Germany, Germany 77761 (+49 7836 50-0; www.vega.com)

Indicators, mass flow

BRONKHORST HIGH-TECH BV, Nijverheidsstraat 1A, Ruurlo, Netherlands NL-7261AK (+31 573458800; www.bronkhorst.com)
FCI-FLUID COMPONENTS INTERNATIONAL, 1755 La Costa Meadows Dr., San Marcos, CA 92078 (760-744-6950; FAX: 760-736-6250; eflow@fluidcomponents.com; www.fluidcomponents.com)
SIERRA INSTRUMENTS, INC., 5 Harris Ct., Bldg. L, Monterey, CA 93940 (831-373-0200; FAX: 831-373-4402; info@sierrainstruments.com; www.sierrainstruments.com)

Indicators, solids level

AUTOMATION PRODUCTS INC. (DYNATROL DIV.), 3030 Maxroy St., Houston, TX 77008 (713-869-0361; FAX: 713-869-7332; sales@dynamtrolusa.com; www.dynamtrolusa.com)
ENDRESS & HAUSER INC, 2350 Endress Place, Greenwood, IN 46143 (317-535-7138; FAX: 317-535-8498; www.endress.com)
VEGA AMERICAS, INC., 4170 Rosslyn Drive, Cincinnati, OH 45209 (513-272-0131; FAX: 513-272-0133; www.vega.com)
VEGA GRIESHABER KG, Am Hohenstein 113, Schiltach, Germany, Germany 77761 (+49 7836 50-0; www.vega.com)

Indicators, specific gravity

AUTOMATION PRODUCTS INC. (DYNATROL DIV.), 3030 Maxroy St., Houston, TX 77008 (713-869-0361; FAX: 713-869-7332; sales@dynamtrolusa.com; www.dynamtrolusa.com)

Indicators, temperature

FCI-FLUID COMPONENTS INTERNATIONAL, 1755 La Costa Meadows Dr., San Marcos, CA 92078 (760-744-6950; FAX: 760-736-6250; eflow@fluidcomponents.com; www.fluidcomponents.com)

Indicators, viscosity

AUTOMATION PRODUCTS INC. (DYNATROL DIV.), 3030 Maxroy St., Houston, TX 77008 (713-869-0361; FAX: 713-869-7332; sales@dynamtrolusa.com; www.dynamtrolusa.com)
LOAD CONTROLS, INC., 53 Technology Park Rd., Sturbridge, MA 01566 (508-347-2606; FAX: 508-347-2064)
 —See our ad on page 12

Indicators, weight

METTLER-TOLEDO, LLC, 1900 Polaris Pkwy., Columbus, OH 43240-4518 (1-800-METTLER; FAX: 614-438-4518)

Thermometers, infrared

AMETEK Land, Dronfield, United Kingdom
 PCE Instruments UK Ltd, Southampton, Hampshire, United Kingdom

Thermostats

LAUDA DR. R. WOBSE GMBH & CO. KG, Lauda-Koenigshofen, Germany

MEASUREMENT & TESTING EQUIPMENT

Calibration & test equipment

FRITSCH GmbH - Milling and Sizing, Idar-Oberstein, Idar-Oberstein, Germany
 LAUDA DR. R. WOBSE GMBH & CO. KG, Lauda-Koenigshofen, Germany
SIERRA INSTRUMENTS, INC., 5 Harris Ct., Bldg. L, Monterey, CA 93940 (831-373-0200; FAX: 831-373-4402; info@sierrainstruments.com; www.sierrainstruments.com)

Calibration gas standards

SIERRA INSTRUMENTS, INC., 5 Harris Ct., Bldg. L, Monterey, CA 93940 (831-373-0200; FAX: 831-373-4402; info@sierrainstruments.com; www.sierrainstruments.com)

Calorimeters

PARR INSTRUMENT COMPANY, 211 53rd Street, Moline, IL 61265 (309-762-7716; FAX: 309-762-9453; randolph@parrinst.com; www.parrinst.com)

Chambers, test

Capovani Brothers Inc., Scotia, NY

Corrosion measurement equipment

PARR INSTRUMENT COMPANY, 211 53rd Street, Moline, IL 61265 (309-762-7716; FAX: 309-762-9453; randolph@parrinst.com; www.parrinst.com)

Density-measuring equipment

AUTOMATION PRODUCTS INC. (DYNATROL DIV.), 3030 Maxroy St., Houston, TX 77008 (713-869-0361; FAX: 713-869-7332; sales@dynamtrolusa.com; www.dynamtrolusa.com)
JENIKE & JOHANSON INC., 400 Business Park Dr., Tyngsboro, MA 01879-1077 (978-649-3300; FAX: 978-649-3399)
 LAUDA DR. R. WOBSE GMBH & CO. KG, Lauda-Koenigshofen, Germany
SARTORIUS - CHEMICAL & CONSUMER CARE, Otto-Brenner-Straße 20, Goettingen, Germany 37079 (+49-(0)551 3084756; www.sartorius.com/chemicals)

Detectors, interface

AUTOMATION PRODUCTS INC. (DYNATROL DIV.), 3030 Maxroy St., Houston, TX 77008 (713-869-0361; FAX: 713-869-7332; sales@dynamtrolusa.com; www.dynamtrolusa.com)
FCI-FLUID COMPONENTS INTERNATIONAL, 1755 La Costa Meadows Dr., San Marcos, CA 92078 (760-744-6950; FAX: 760-736-6250; eflow@fluidcomponents.com; www.fluidcomponents.com)

Detectors, leak

Capovani Brothers Inc., Scotia, NY

FCI-FLUID COMPONENTS INTERNATIONAL, 1755 La Costa Meadows Dr., San Marcos, CA 92078 (760-744-6950; FAX: 760-736-6250; eflow@fluidcomponents.com; www.fluidcomponents.com)

Pfeiffer Vacuum GmbH, Asslar, Germany

SIERRA INSTRUMENTS, INC., 5 Harris Ct., Bldg. L, Monterey, CA 93940 (831-373-0200; FAX: 831-373-4402; info@sierrainstruments.com; www.sierrainstruments.com)

TLV CORPORATION, 13901 S. Lakes Dr., Charlotte, NC 28273 (704-597-9070; FAX: 704-583-1610; www.tlv.com)

—See our ad on page 65

Electrodes, pH

METTLER-TOLEDO PROCESS ANALYTICS, 900 Middlesex Turnpike, Building 8, Billerica, MA 01821 (800-352-8736; FAX: 781-301-8701)

Manometers

VEGA AMERICAS, INC., 4170 Rosslyn Drive, Cincinnati, OH 45209 (513-272-0131; FAX: 513-272-0133; www.vega.com)

VEGA GRIESHABER KG, Am Hohenstein 113, Schiltach, Germany, Germany 77761 (+49 7836 50-0; www.vega.com)

Meters, air

FCI-FLUID COMPONENTS INTERNATIONAL, 1755 La Costa Meadows Dr., San Marcos, CA 92078 (760-744-6950; FAX: 760-736-6250; eflow@fluidcomponents.com; www.fluidcomponents.com)

FOX THERMAL, 399 Reservation Road, Marina, CA 93933 (831-381-4300; www.foxthermal.com)

SIERRA INSTRUMENTS, INC., 5 Harris Ct., Bldg. L, Monterey, CA 93940 (831-373-0200; FAX: 831-373-4402; info@sierrainstruments.com; www.sierrainstruments.com)

Meters, displacement

Badger Meter, Inc., Milwaukee, WI

Meters, gas

FCI-FLUID COMPONENTS INTERNATIONAL, 1755 La Costa Meadows Dr., San Marcos, CA 92078 (760-744-6950; FAX: 760-736-6250; eflow@fluidcomponents.com; www.fluidcomponents.com)

FOX THERMAL, 399 Reservation Road, Marina, CA 93933 (831-381-4300; www.foxthermal.com)

SICK, INC., 6900 West 110th Street, Bloomington, MN 55438 (800-325-7425; www.sick.com)

SIERRA INSTRUMENTS, INC., 5 Harris Ct., Bldg. L, Monterey, CA 93940 (831-373-0200; FAX: 831-373-4402; info@sierrainstruments.com; www.sierrainstruments.com)

Meters, heat flow

FCI-FLUID COMPONENTS INTERNATIONAL, 1755 La Costa Meadows Dr., San Marcos, CA 92078 (760-744-6950; FAX: 760-736-6250; eflow@fluidcomponents.com; www.fluidcomponents.com)

Meters, oxygen

FOX THERMAL, 399 Reservation Road, Marina, CA 93933 (831-381-4300; www.foxthermal.com)

SICK, INC., 6900 West 110th Street, Bloomington, MN 55438 (800-325-7425; www.sick.com)

Meters, pH

MYRON L COMPANY, 2450 Impala Drive, Carlsbad, CA 92010 (760-438-2021; FAX: 760-931-9189; www.myronl.com)

—See our ad on page 20

Meters, ultrasonic

BLUE-WHITE INDUSTRIES, 5300 Business Drive, Huntington Beach, CA 92649 (714-893-8529; FAX: 714-895-9492; sales@blue-white.com; www.blue-white.com)

SICK, INC., 6900 West 110th Street, Bloomington, MN 55438 (800-325-7425; www.sick.com)

SIEMENS PROCESS INSTRUMENTATION, 2060

Detwiler Road, Suite 111, Harleysville, PA 19438 (800-365-8766; piabu-requestinformation.industry@siemens.com; www.usa.siemens.com/pablog)

SIERRA INSTRUMENTS, INC., 5 Harris Ct., Bldg. L, Monterey, CA 93940 (831-373-0200; FAX: 831-373-4402; info@sierrainstruments.com; www.sierrainstruments.com)

TLV CORPORATION, 13901 S. Lakes Dr., Charlotte, NC 28273 (704-597-9070; FAX: 704-583-1610; www.tlv.com)

—See our ad on page 65

Meters, water

FCI-FLUID COMPONENTS INTERNATIONAL, 1755 La Costa Meadows Dr., San Marcos, CA 92078 (760-744-6950; FAX: 760-736-6250; eflow@fluidcomponents.com; www.fluidcomponents.com)

MYRON L COMPANY, 2450 Impala Drive, Carlsbad, CA 92010 (760-438-2021; FAX: 760-931-9189; www.myronl.com)

—See our ad on page 20

SIEMENS PROCESS INSTRUMENTATION, 2060 Detwiler Road, Suite 111, Harleysville, PA 19438 (800-365-8766; piabu-requestinformation.industry@siemens.com; www.usa.siemens.com/pablog)

Microscopes

Capovani Brothers Inc., Scotia, NY

Pyrometers

AMETEK Land, Dronfield, United Kingdom

Tachometers

PCE Instruments UK Ltd, Southampton, Hampshire, United Kingdom

Testing equipment, other

JENIKE & JOHANSON INC., 400 Business Park Dr., Tyngsboro, MA 01879-1077 (978-649-3300; FAX: 978-649-3399)

SIERRA INSTRUMENTS, INC., 5 Harris Ct., Bldg. L, Monterey, CA 93940 (831-373-0200; FAX: 831-373-4402; info@sierrainstruments.com; www.sierrainstruments.com)

TLV CORPORATION, 13901 S. Lakes Dr., Charlotte, NC 28273 (704-597-9070; FAX: 704-583-1610; www.tlv.com)

—See our ad on page 65

UIC INC., 1225 Channahon Rd., P.O. Box 863, Joliet, IL 60434-0863 (815-744-4477; FAX: 815-744-1561; warmstrong@uicinc.com; www.uicinc.com)

Viscosity or consistency instruments, other

AUTOMATION PRODUCTS INC. (DYNATROL DIV.), 3030 Maxroy St., Houston, TX 77008 (713-869-0361; FAX: 713-869-7332; sales@dynamtrolusa.com; www.dynamtrolusa.com)

LOAD CONTROLS, INC., 53 Technology Park Rd., Sturbridge, MA 01566 (508-347-2606; FAX: 508-347-2064)

—See our ad on page 12

RECORDERS

Recorders, mass flow

SIERRA INSTRUMENTS, INC., 5 Harris Ct., Bldg. L, Monterey, CA 93940 (831-373-0200; FAX: 831-373-4402; info@sierrainstruments.com; www.sierrainstruments.com)

TRANSMITTERS & DATA TRANSMISSION EQUIPMENT

Converters, signal

ABB INC., 3700 West Sam Houston Parkway South, Houston, TX 77042 (1-800-HELP-365; FAX: 440-585-7071; contact.center@us.abb.com; www.abb.com/chemical)

PEPPERL+FUCHS SE, Lilienthalstrasse 200, Mannheim, Germany 68307 (+49-621-776-0; FAX: +49-621-776-1000; www.pepperl-fuchs.com)

Phoenix Contact GmbH & Co.KG, Blomberg, Germany R. STAHL, Waldenburg, Germany

Data Transmission, Wireless

PEPPERL+FUCHS SE, Lilienthalstrasse 200, Mannheim, Germany 68307 (+49-621-776-0; FAX: +49-621-776-1000; www.pepperl-fuchs.com)

Phoenix Contact GmbH & Co.KG, Blomberg, Germany R. STAHL, Waldenburg, Germany

Electrical equipment, intrinsic safety

I.SAFE MOBILE GMBH, i_Park Tauberfranken 10, Lauda-Koenigshofen, Germany 97922 (+49 9343 601480)

PEPPERL+FUCHS SE, Lilienthalstrasse 200, Mannheim, Germany 68307 (+49-621-776-0; FAX: +49-621-776-1000; www.pepperl-fuchs.com)

R. STAHL, Waldenburg, Germany

Radio remote control systems

PEPPERL+FUCHS SE, Lilienthalstrasse 200, Mannheim, Germany 68307 (+49-621-776-0; FAX: +49-621-776-1000; www.pepperl-fuchs.com)

Relays, time delay

PEPPERL+FUCHS SE, Lilienthalstrasse 200, Mannheim, Germany 68307 (+49-621-776-0; FAX: +49-621-776-1000; www.pepperl-fuchs.com)

Transmitters, level

Buerkert Fluid Control Systems, Ingelfingen, Germany

ENDRESS & HAUSER INC, 2350 Endress Place, Greenwood, IN 46143 (317-535-7138; FAX: 317-535-8498; www.endress.com)

FCI-FLUID COMPONENTS INTERNATIONAL, 1755 La Costa Meadows Dr., San Marcos, CA 92078 (760-744-6950; FAX: 760-736-6250; eflow@fluidcomponents.com; www.fluidcomponents.com)

HONEYWELL PROCESS SOLUTIONS, 1250 W Sam Houston Pkwy S, Houston, TX 77042 (832-252-3500; www.honeywellprocess.com)

PEPPERL+FUCHS SE, Lilienthalstrasse 200, Mannheim, Germany 68307 (+49-621-776-0; FAX: +49-621-776-1000; www.pepperl-fuchs.com)

SIEMENS PROCESS INSTRUMENTATION, 2060 Detwiler Road, Suite 111, Harleysville, PA 19438 (800-365-8766; piabu-requestinformation.industry@siemens.com; www.usa.siemens.com/pablog)

VEGA AMERICAS, INC., 4170 Rosslyn Drive, Cincinnati, OH 45209 (513-272-0131; FAX: 513-272-0133; www.vega.com)

VEGA GRIESHABER KG, Am Hohenstein 113, Schiltach, Germany, Germany 77761 (+49 7836 50-0; www.vega.com)

Transmitters, mass flow

AIR MONITOR CORPORATION, 1050 Hopper Ave, Santa Rosa, CA 95403 (1-800-AIRFLOW; FAX: 707-526-9970; www.airmonitor.com)

FCI-FLUID COMPONENTS INTERNATIONAL, 1755 La Costa Meadows Dr., San Marcos, CA 92078 (760-744-6950; FAX: 760-736-6250; eflow@fluidcomponents.com; www.fluidcomponents.com)

FOX THERMAL, 399 Reservation Road, Marina, CA 93933 (831-381-4300; www.foxthermal.com)

HONEYWELL PROCESS SOLUTIONS, 1250 W Sam Houston Pkwy S, Houston, TX 77042 (832-252-3500; www.honeywellprocess.com)

SIEMENS PROCESS INSTRUMENTATION, 2060 Detwiler Road, Suite 111, Harleysville, PA 19438 (800-365-8766; piabu-requestinformation.industry@siemens.com; www.usa.siemens.com/pablog)

Transmitters, pressure

ENDRESS & HAUSER INC, 2350 Endress Place, Greenwood, IN 46143 (317-535-7138; FAX: 317-535-8498; www.endress.com)

HONEYWELL PROCESS SOLUTIONS, 1250 W Sam Houston Pkwy S, Houston, TX 77042 (832-252-3500; www.honeywellprocess.com)

PEPPERL+FUCHS SE, Lilienthalstrasse 200, Mannheim, Germany 68307 (+49-621-776-0; FAX: +49-621-776-1000; www.pepperl-fuchs.com)

Pfeiffer Vacuum GmbH, Asslar, Germany

SIEMENS PROCESS INSTRUMENTATION, 2060 Detwiler Road, Suite 111, Harleysville, PA 19438 (800-365-8766; piabu-requestinformation.industry@siemens.com; www.usa.siemens.com/pablog)

VEGA AMERICAS, INC., 4170 Rosslyn Drive, Cincinnati, OH 45209 (513-272-0131; FAX: 513-272-0133; www.vega.com)

VEGA GRIESHABER KG, Am Hohenstein 113, Schiltach, Germany, Germany 77761 (+49 7836 50-0; www.vega.com)

Transmitters, pressure-critical

SIEMENS PROCESS INSTRUMENTATION, 2060 Detwiler Road, Suite 111, Harleysville, PA 19438 (800-365-8766; piabu-requestinformation.industry@siemens.com; www.usa.siemens.com/pablog)

Transmitters, temperature

FCI-FLUID COMPONENTS INTERNATIONAL, 1755 La Costa Meadows Dr., San Marcos, CA 92078 (760-744-6950; FAX: 760-736-6250; eflow@fluidcomponents.com; www.fluidcomponents.com)

FOX THERMAL, 399 Reservation Road, Marina, CA 93933 (831-381-4300; www.foxthermal.com)

PEPPERL+FUCHS SE, Lilienthalstrasse 200, Mannheim, Germany 68307 (+49-621-776-0; FAX: +49-621-776-1000; www.pepperl-fuchs.com)

SIEMENS PROCESS INSTRUMENTATION, 2060 Detwiler Road, Suite 111, Harleysville, PA 19438 (800-365-8766; piabu-requestinformation.industry@siemens.com; www.usa.siemens.com/pablog)

5

PROCESSING EQUIPMENT

- 82 Associations
- 82 Air conditioning & refrigeration equipment
- 82 Centrifuges
- 83 Classifiers & gravity separators
- 83 Cooling tower systems
- 83 Custom fabricated equipment
- 83 Dryers
- 85 Dust collectors & separators
- 85 Electrochemical equipment
- 85 Entrainment separation equipment
- 85 Evaporators & crystallizers
- 86 Filter media & aids
- 86 Filtration equipment
- 87 Heat exchangers, condensers & coolers
- 88 Heat transfer media
- 88 Heating & cooling equipment, other
- 89 Kilns, ovens & furnaces
- 89 Mixing equipment for fluids
- 90 Mixing equipment for solids & fluids
- 92 Packings, trays for towers & columns
- 92 Process vessels & reactors
- 93 Reaction & separation equipment, other
- 93 Screening equipment
- 93 Scrubbers
- 94 Size reduction equipment
- 94 Towers & columns
- 95 Water treatment equipment

ASSOCIATIONS

DECHEMA E.V., Theodor-Heuss-Allee 25, Frankfurt am Main, Germany 60486 (49-69-75-64-0; FAX: 49-69-75-64-201; www.dechema.de)
— See our ad on page 22

AIR CONDITIONING & REFRIGERATION EQUIPMENT

Refrigeration equipment & systems

GEA GROUP, 9165 Rumsey Road, Columbia, MD 21045 (800-722-6622; www.gea.com)
— See our ad on page 23
Mokon, Buffalo, NY
Thermal Care, Niles, IL

Refrigeration equipment, chillers

GEA GROUP, 9165 Rumsey Road, Columbia, MD 21045 (800-722-6622; www.gea.com)
— See our ad on page 23
KOERTING HANNOVER GMBH, Badenstedter Str. 56, Hannover, Germany 30453 (0511-2129-0; FAX: 0511-2129-223)
— See our ad on page 69
Mokon, Buffalo, NY
Thermal Care, Niles, IL

Refrigeration equipment, freezers

BENKO PRODUCTS, INC., 5350 Evergreen Pkwy., Sheffield Village, OH 44054 (440-934-2180; FAX: 440-934-4052; www.benkoproducts.com)

CENTRIFUGES

Centrifuge parts & accessories

ANDRITZ SEPARATION, ANDRITZ AG, Stattegger Strasse 18, Graz, Austria 8045 (+43 050 8050; separation@andritz.com; www.andritz.com/separation)
GEA GROUP, 9165 Rumsey Road, Columbia, MD 21045 (800-722-6622; www.gea.com)
— See our ad on page 23

Centrifuges, batch, automatic basket

ANDRITZ SEPARATION, ANDRITZ AG, Stattegger Strasse 18, Graz, Austria 8045 (+43 050 8050; separation@andritz.com; www.andritz.com/separation)

Centrifuges, batch, perforated basket

ANDRITZ SEPARATION, ANDRITZ AG, Stattegger Strasse 18, Graz, Austria 8045 (+43 050 8050; separation@andritz.com; www.andritz.com/separation)

Centrifuges, continuous, conical angle, perforated basket

ANDRITZ SEPARATION, ANDRITZ AG, Stattegger Strasse 18, Graz, Austria 8045 (+43 050 8050; separation@andritz.com; www.andritz.com/separation)

Centrifuges, continuous, pusher discharge

ANDRITZ SEPARATION, ANDRITZ AG, Stattegger Strasse 18, Graz, Austria 8045 (+43 050 8050; separation@andritz.com; www.andritz.com/separation)

Centrifuges, continuous, solid bowl, scroll discharge

ANDRITZ SEPARATION, ANDRITZ AG, Stattegger Strasse 18, Graz, Austria 8045 (+43 050 8050; separation@andritz.com; www.andritz.com/separation)

Flottweg SE, Vilsbiburg, Germany
GEA GROUP, 9165 Rumsey Road, Columbia, MD 21045 (800-722-6622; www.gea.com)
— See our ad on page 23

Centrifuges, disc, nozzle discharge

GEA GROUP, 9165 Rumsey Road, Columbia, MD 21045 (800-722-6622; www.gea.com)
— See our ad on page 23

Centrifuges, disc, solid bowl

ANDRITZ SEPARATION, ANDRITZ AG, Stattegger Strasse 18, Graz, Austria 8045 (+43 050 8050; separation@andritz.com; www.andritz.com/separation)

Flottweg SE, Vilsbiburg, Germany
GEA GROUP, 9165 Rumsey Road, Columbia, MD 21045 (800-722-6622; www.gea.com)
— See our ad on page 23

Centrifuges, disc, valve discharge

Flottweg SE, Vilsbiburg, Germany
GEA GROUP, 9165 Rumsey Road, Columbia, MD 21045 (800-722-6622; www.gea.com)
— See our ad on page 23

Centrifuges, filter, continuous, screen bowl, scroll discharge

ANDRITZ SEPARATION, ANDRITZ AG, Stattegger Strasse 18, Graz, Austria 8045 (+43 050 8050; separation@andritz.com; www.andritz.com/separation)

Centrifuges, laboratory or pilot plant

ANDRITZ SEPARATION, ANDRITZ AG, Stattegger Strasse 18, Graz, Austria 8045 (+43 050 8050; separation@andritz.com; www.andritz.com/separation)
GEA GROUP, 9165 Rumsey Road, Columbia, MD 21045 (800-722-6622; www.gea.com)
— See our ad on page 23

Centrifuges, liquid-liquid

B&P LITTLEFORD, 1000 Hess Avenue, Saginaw, MI 48601 (989-757-1300; FAX: 989-757-1301; www.bplittleford.com)
 Flottweg SE, Vilsbiburg, Germany
GEA GROUP, 9165 Rumsey Road, Columbia, MD 21045 (800-722-6622; www.gea.com)
 —See our ad on page 23

Centrifuges, solid basket

ANDRITZ SEPARATION, ANDRITZ AG, Stattegger Strasse 18, Graz, Austria 8045 (+43 050 8050; separation@andritz.com; www.andritz.com/separation)

CLASSIFIERS & GRAVITY SEPARATORS

Classifiers, air

METSO MINERALS INDUSTRIES, INC., 2715 Pleasant Valley Road, York, PA 17402 (717-843-8671; FAX: 717-845-5154; www.metso.com)
 —See our ad on page 39

Classifiers, cyclone

KOCH-GLITSCH, INC., 4111 E. 37th St. N., Wichita, KS 67220 (316-828-5110; FAX: 316-828-7985)
 —See our ad inside front cover

Decanters

ANDRITZ SEPARATION, ANDRITZ AG, Stattegger Strasse 18, Graz, Austria 8045 (+43 050 8050; separation@andritz.com; www.andritz.com/separation)
GEA GROUP, 9165 Rumsey Road, Columbia, MD 21045 (800-722-6622; www.gea.com)
 —See our ad on page 23

Liquid-liquid processing

KOCH-GLITSCH, INC., 4111 E. 37th St. N., Wichita, KS 67220 (316-828-5110; FAX: 316-828-7985)
 —See our ad inside front cover
 Pentair, Conroe, TX

Particle size control systems

FRI TSCH GmbH - Milling and Sizing, Idar-Oberstein, Idar-Oberstein, Germany
 Pentair, Conroe, TX

Thickeners, centrifugal

ANDRITZ SEPARATION, ANDRITZ AG, Stattegger Strasse 18, Graz, Austria 8045 (+43 050 8050; separation@andritz.com; www.andritz.com/separation)
GEA GROUP, 9165 Rumsey Road, Columbia, MD 21045 (800-722-6622; www.gea.com)
 —See our ad on page 23

Thickeners, gravity

ANDRITZ SEPARATION, ANDRITZ AG, Stattegger Strasse 18, Graz, Austria 8045 (+43 050 8050; separation@andritz.com; www.andritz.com/separation)

Thickeners, rake or sedimentation

ANDRITZ SEPARATION, ANDRITZ AG, Stattegger Strasse 18, Graz, Austria 8045 (+43 050 8050; separation@andritz.com; www.andritz.com/separation)
HENG FENG TAI PRECISION MACHINERY Co. for MIXING and THICKENING SOLUTIONS since 1991, Wenzhou, Wenzhou, China

COOLING TOWER SYSTEMS

Cooling towers

Kelvion, Bochum, Germany
 Mokon, Buffalo, NY
 Thermal Care, Niles, IL

CUSTOM FABRICATED EQUIPMENT

Equipment, process, custom

PAUL O. ABBE, 201 Hanson Ct. Suite 125, Wood Dale, IL 60191 (630-350-3012; FAX: 630-238-7584)
 —See our ad on page 15
 Caloris Engineering, Easton, MD
 CAST-X Circulation Heaters, Batavia, IL
EKATO RUEHR- UND MISCHTECHNIK GMBH, Hohe-Flum-Str.37, Schopfheim, Germany D-79650 (+49 7622 290; FAX: +49 7622 29 213; www.ekato.com)
 —See our ad on page 84

FLUID LINE PRODUCTS INC., 38273 Western Pkwy., P.O. Box 1000, Willoughby, OH 44096 (440-946-9470; FAX: 440-946-9472; www.fluidline.com)
IPCO GERMANY GMBH, Salierstr. 35, Fellbach, Germany 70736 (+49 711 5105 0)
JAYGO, INC., 7 Emery Ave., Randolph, NJ 07869 (908-688-3600; FAX: 908-688-6060)
KOCH-GLITSCH, INC., 4111 E. 37th St. N., Wichita, KS 67220 (316-828-5110; FAX: 316-828-7985)
 —See our ad inside front cover
MATERIAL TRANSFER & STORAGE INC., 1214 Lincoln Rd., P.O. Box 218, Allegan, MI 49010-0218 (269-673-2125; FAX: 269-673-4883; www.materialtransfer.com)
 Myers Mixers, Cudahy, CA
 Pentair, Conroe, TX
POPE SCIENTIFIC, INC., P.O. Box 80018, 351 N. Dekora Woods Blvd., Saukville, WI 53080 (262-268-9300; FAX: 262-268-9400; info@popeinc.com; www.popeinc.com)
ROSS MIXERS, 710 Old Willets Path, P.O. Box 12308, Hauppauge, NY 11788-0615 (631-234-0500; FAX: 631-234-0691; www.mixers.com)

Equipment, process, custom, cryogenic

CAST-X Circulation Heaters, Batavia, IL
 NEUHAUS NEOTEC Maschinen- und Anlagenbau GmbH, Ganderkesee, Germany
 Pentair, Conroe, TX
POPE SCIENTIFIC, INC., P.O. Box 80018, 351 N. Dekora Woods Blvd., Saukville, WI 53080 (262-268-9300; FAX: 262-268-9400; info@popeinc.com; www.popeinc.com)
ROSS MIXERS, 710 Old Willets Path, P.O. Box 12308, Hauppauge, NY 11788-0615 (631-234-0500; FAX: 631-234-0691; www.mixers.com)

DRYERS

Dryer parts & accessories

PAUL O. ABBE, 201 Hanson Ct. Suite 125, Wood Dale, IL 60191 (630-350-3012; FAX: 630-238-7584)
 —See our ad on page 15
 AMANDUS KAHL GmbH & Co. KG, Reinbek, Germany
ANDRITZ SEPARATION, ANDRITZ AG, Stattegger Strasse 18, Graz, Austria 8045 (+43 050 8050; separation@andritz.com; www.andritz.com/separation)
 CAST-X Circulation Heaters, Batavia, IL

Dryers, air

CAST-X Circulation Heaters, Batavia, IL
DYNAMIC AIR INC., 1125 Willow Lake Blvd., St. Paul, MN 55110-5193 (651-484-2900; FAX: 651-484-7015; www.dynamicair.com)

Dryers, batch

PAUL O. ABBE, 201 Hanson Ct. Suite 125, Wood Dale, IL 60191 (630-350-3012; FAX: 630-238-7584)
 —See our ad on page 15
JAYGO, INC., 7 Emery Ave., Randolph, NJ 07869 (908-688-3600; FAX: 908-688-6060)
ROSS MIXERS, 710 Old Willets Path, P.O. Box 12308, Hauppauge, NY 11788-0615 (631-234-0500; FAX: 631-234-0691; www.mixers.com)

Dryers, belt

AMANDUS KAHL GmbH & Co. KG, Reinbek, Germany
ANDRITZ SEPARATION, ANDRITZ AG, Stattegger Strasse 18, Graz, Austria 8045 (+43 050 8050; separation@andritz.com; www.andritz.com/separation)
BERNDORF BAND GROUP, Leobersdorferstr. 26, Berndorf, Austria 2560 (43-2672-800-0; FAX: 43-2672-84176; www.berndorfband-group.com)

Dryers, centrifugal

JLS INTERNATIONAL, INC., 381 Fawn Lane, West Jefferson, NC 28694 (336-877-5571; FAX: 336-877-5579)
METSO MINERALS INDUSTRIES, INC., 2715 Pleasant Valley Road, York, PA 17402 (717-843-8671; FAX: 717-845-5154; www.metso.com)
 —See our ad on page 39

Dryers, closed circuit

BUSS-SMS-CANZLER GMBH, Kaiserstr. 13-15, Butzbach, Germany 35510 (49-6033-85-0; FAX: 49-6033-85-249)
DEDERT CORPORATION, 17740 Hoffman way, Homewood, IL 60430 (708-747-7000; c.crankshaw@dedert.com; www.dedert.com)
 WYSSMONT COMPANY, INC., Fort Lee, NJ

Dryers, conical, vacuum

PAUL O. ABBE, 201 Hanson Ct. Suite 125, Wood Dale, IL 60191 (630-350-3012; FAX: 630-238-7584)
 —See our ad on page 15
EKATO RUEHR- UND MISCHTECHNIK GMBH, Hohe-Flum-Str.37, Schopfheim, Germany D-79650 (+49 7622 290; FAX: +49 7622 29 213; www.ekato.com)
 —See our ad on page 84

FLUID LINE PRODUCTS INC., 38273 Western Pkwy., P.O. Box 1000, Willoughby, OH 44096 (440-946-9470; FAX: 440-946-9472; www.fluidline.com)
JAYGO, INC., 7 Emery Ave., Randolph, NJ 07869 (908-688-3600; FAX: 908-688-6060)
ROSS MIXERS, 710 Old Willets Path, P.O. Box 12308, Hauppauge, NY 11788-0615 (631-234-0500; FAX: 631-234-0691; www.mixers.com)

Dryers, continuous

PAUL O. ABBE, 201 Hanson Ct. Suite 125, Wood Dale, IL 60191 (630-350-3012; FAX: 630-238-7584)
 —See our ad on page 15
 AMANDUS KAHL GmbH & Co. KG, Reinbek, Germany
BUSS-SMS-CANZLER GMBH, Kaiserstr. 13-15, Butzbach, Germany 35510 (49-6033-85-0; FAX: 49-6033-85-249)
DYNAMIC AIR INC., 1125 Willow Lake Blvd., St. Paul, MN 55110-5193 (651-484-2900; FAX: 651-484-7015; www.dynamicair.com)
 WYSSMONT COMPANY, INC., Fort Lee, NJ

Dryers, conveyor

IPCO GERMANY GMBH, Salierstr. 35, Fellbach, Germany 70736 (+49 711 5105 0)

Dryers, drum

ANDRITZ SEPARATION, ANDRITZ AG, Stattegger Strasse 18, Graz, Austria 8045 (+43 050 8050; separation@andritz.com; www.andritz.com/separation)
GEA GROUP, 9165 Rumsey Road, Columbia, MD 21045 (800-722-6622; www.gea.com)
 —See our ad on page 23
JLS INTERNATIONAL, INC., 381 Fawn Lane, West Jefferson, NC 28694 (336-877-5571; FAX: 336-877-5579)

Dryers, drum, rotary vacuum

PAUL O. ABBE, 201 Hanson Ct. Suite 125, Wood Dale, IL 60191 (630-350-3012; FAX: 630-238-7584)
 —See our ad on page 15
JAYGO, INC., 7 Emery Ave., Randolph, NJ 07869 (908-688-3600; FAX: 908-688-6060)

Dryers, electric

CAST-X Circulation Heaters, Batavia, IL
 WYSSMONT COMPANY, INC., Fort Lee, NJ

Dryers, flash

COMESSA, Strasbourg, France
DEDERT CORPORATION, 17740 Hoffman way, Homewood, IL 60430 (708-747-7000; c.crankshaw@dedert.com; www.dedert.com)
GEA GROUP, 9165 Rumsey Road, Columbia, MD 21045 (800-722-6622; www.gea.com)
 —See our ad on page 23

Dryers, fluidized bed

PAUL O. ABBE, 201 Hanson Ct. Suite 125, Wood Dale, IL 60191 (630-350-3012; FAX: 630-238-7584)
 —See our ad on page 15
ANDRITZ SEPARATION, ANDRITZ AG, Stattegger Strasse 18, Graz, Austria 8045 (+43 050 8050; separation@andritz.com; www.andritz.com/separation)
 COMESSA, Strasbourg, France
DEDERT CORPORATION, 17740 Hoffman way, Homewood, IL 60430 (708-747-7000; c.crankshaw@dedert.com; www.dedert.com)

DYNAMIC AIR INC., 1125 Willow Lake Blvd., St. Paul, MN 55110-5193 (651-484-2900; FAX: 651-484-7015; www.dynamicair.com)
GEA GROUP, 9165 Rumsey Road, Columbia, MD 21045 (800-722-6622; www.gea.com)
 —See our ad on page 23
 NEUHAUS NEOTEC Maschinen- und Anlagenbau GmbH, Ganderkesee, Germany

Dryers, freeze

GEA GROUP, 9165 Rumsey Road, Columbia, MD 21045 (800-722-6622; www.gea.com)
 —See our ad on page 23

Dryers, gas

WYSSMONT COMPANY, INC., Fort Lee, NJ

Dryers, paddle

PAUL O. ABBE, 201 Hanson Ct. Suite 125, Wood Dale, IL 60191 (630-350-3012; FAX: 630-238-7584)
 —See our ad on page 15
ANDRITZ SEPARATION, ANDRITZ AG, Stattegger Strasse 18, Graz, Austria 8045 (+43 050 8050; separation@andritz.com; www.andritz.com/separation)
DYNAMIC AIR INC., 1125 Willow Lake Blvd., St. Paul, MN 55110-5193 (651-484-2900; FAX: 651-484-7015; www.dynamicair.com)
GEA GROUP, 9165 Rumsey Road, Columbia, MD 21045 (800-722-6622; www.gea.com)
 —See our ad on page 23

EKATO

www.ekato.com



CONSULTING ENGINEERING MODERNIZATION

YOUR PROCESSES ARE
DEVELOPING – WHAT ABOUT
YOUR MACHINES?

- ANALYSIS OF YOUR MIXING PROCESS
- ASSESSMENT OF CURRENT EQUIPMENT
- DEVELOPMENT OF TAILORMADE SOLUTIONS
- VERIFICATION BY MEANS OF FEM AND LABORATORY TESTS INCLUDING FLOW SIMULATION (IF NECESSARY)

Catch up on our current workshop
and seminar program:

www.ekato.com

Your partner for
advanced mixing solutions:
Phone: 1 201 825 4684 Ext.: 205
cem@ekato.com

PRODUCT DIRECTORY

JAYGO, INC., 7 Emery Ave., Randolph, NJ 07869 (908-688-3600; FAX: 908-688-6060)
ROSS MIXERS, 710 Old Willets Path, P.O. Box 12308, Hauppauge, NY 11788-0615 (631-234-0500; FAX: 631-234-0691; www.mixers.com)

Dryers, pan

JAYGO, INC., 7 Emery Ave., Randolph, NJ 07869 (908-688-3600; FAX: 908-688-6060)
JLS INTERNATIONAL, INC., 381 Fawn Lane, West Jefferson, NC 28694 (336-877-5571; FAX: 336-877-5579)

Dryers, ring

DEDERT CORPORATION, 17740 Hoffman way, Homewood, IL 60430 (708-747-7000; c.crankshaw@dedert.com; www.dedert.com)
GEA GROUP, 9165 Rumsey Road, Columbia, MD 21045 (800-722-6622; www.gea.com)
—See our ad on page 23

Dryers, rotary

PAUL O. ABBE, 201 Hanson Ct. Suite 125, Wood Dale, IL 60191 (630-350-3012; FAX: 630-238-7584)
—See our ad on page 15
COMESSA, Strasbourg, France
GEA GROUP, 9165 Rumsey Road, Columbia, MD 21045 (800-722-6622; www.gea.com)
—See our ad on page 23
JAYGO, INC., 7 Emery Ave., Randolph, NJ 07869 (908-688-3600; FAX: 908-688-6060)
METSO MINERALS INDUSTRIES, INC., 2715 Pleasant Valley Road, York, PA 17402 (717-843-8671; FAX: 717-845-5154; www.metso.com)
—See our ad on page 39

Dryers, screw flight

EKATO RUEHR- UND MISCHTECHNIK GMBH, Hohe-Flum-Str.37, Schopfheim, Germany D-79650 (+49 7622 290; FAX: + 49 7622 29 213; www.ekato.com)
—See our ad on page 84
FLUID LINE PRODUCTS INC., 38273 Western Pkwy., P.O. Box 1000, Willoughby, OH 44096 (440-946-9470; FAX: 440-946-9472; www.fluidline.com)

Dryers, shelf, vacuum

PAUL O. ABBE, 201 Hanson Ct. Suite 125, Wood Dale, IL 60191 (630-350-3012; FAX: 630-238-7584)
—See our ad on page 15
JLS INTERNATIONAL, INC., 381 Fawn Lane, West Jefferson, NC 28694 (336-877-5571; FAX: 336-877-5579)
PINK GMBH THERMOSYSTEME, Am Kessler 6, 97877 Wertheim, Germany (0049-9342-919-0; FAX: 0049-9342-919-111; www.pink.de)

Dryers, spiral screw

PAUL O. ABBE, 201 Hanson Ct. Suite 125, Wood Dale, IL 60191 (630-350-3012; FAX: 630-238-7584)
—See our ad on page 15
EKATO RUEHR- UND MISCHTECHNIK GMBH, Hohe-Flum-Str.37, Schopfheim, Germany D-79650 (+49 7622 290; FAX: + 49 7622 29 213; www.ekato.com)
—See our ad on page 84
FLUID LINE PRODUCTS INC., 38273 Western Pkwy., P.O. Box 1000, Willoughby, OH 44096 (440-946-9470; FAX: 440-946-9472; www.fluidline.com)
ROSS MIXERS, 710 Old Willets Path, P.O. Box 12308, Hauppauge, NY 11788-0615 (631-234-0500; FAX: 631-234-0691; www.mixers.com)

Dryers, spray

Caloris Engineering, Easton, MD
DEDERT CORPORATION, 17740 Hoffman way, Homewood, IL 60430 (708-747-7000; c.crankshaw@dedert.com; www.dedert.com)
GEA GROUP, 9165 Rumsey Road, Columbia, MD 21045 (800-722-6622; www.gea.com)
—See our ad on page 23

Dryers, steam jacketed

PAUL O. ABBE, 201 Hanson Ct. Suite 125, Wood Dale, IL 60191 (630-350-3012; FAX: 630-238-7584)
—See our ad on page 15
BUSS-SMS-CANZLER GMBH, Kaiserstr. 13-15, Butzbach, Germany 35510 (49-6033-85-0; FAX: 49-6033-85-249)
GEA GROUP, 9165 Rumsey Road, Columbia, MD 21045 (800-722-6622; www.gea.com)
—See our ad on page 23
ROSS MIXERS, 710 Old Willets Path, P.O. Box 12308, Hauppauge, NY 11788-0615 (631-234-0500; FAX: 631-234-0691; www.mixers.com)

Dryers, steam tube

GEA GROUP, 9165 Rumsey Road, Columbia, MD 21045 (800-722-6622; www.gea.com)
—See our ad on page 23

Dryers, tray

JLS INTERNATIONAL, INC., 381 Fawn Lane, West Jefferson, NC 28694 (336-877-5571; FAX: 336-877-5579)
KOCH-GLITSCH, INC., 4111 E. 37th St. N., Wichita, KS 67220 (316-828-5110; FAX: 316-828-7985)
—See our ad inside front cover
WYSSMONT COMPANY, INC., Fort Lee, NJ

Dryers, tray, vacuum

JLS INTERNATIONAL, INC., 381 Fawn Lane, West Jefferson, NC 28694 (336-877-5571; FAX: 336-877-5579)
KOCH-GLITSCH, INC., 4111 E. 37th St. N., Wichita, KS 67220 (316-828-5110; FAX: 316-828-7985)
—See our ad inside front cover

Dryers, tumble

PAUL O. ABBE, 201 Hanson Ct. Suite 125, Wood Dale, IL 60191 (630-350-3012; FAX: 630-238-7584)
—See our ad on page 15

GEMCO, the worldwide mixing and drying authority, Middlesex, NJ

JAYGO, INC., 7 Emery Ave., Randolph, NJ 07869 (908-688-3600; FAX: 908-688-6060)

ROSS MIXERS, 710 Old Willets Path, P.O. Box 12308, Hauppauge, NY 11788-0615 (631-234-0500; FAX: 631-234-0691; www.mixers.com)

Dryers, tunnel

COMESSA, Strasbourg, France

Dryers, V cone

PAUL O. ABBE, 201 Hanson Ct. Suite 125, Wood Dale, IL 60191 (630-350-3012; FAX: 630-238-7584)
—See our ad on page 15

JAYGO, INC., 7 Emery Ave., Randolph, NJ 07869 (908-688-3600; FAX: 908-688-6060)

ROSS MIXERS, 710 Old Willets Path, P.O. Box 12308, Hauppauge, NY 11788-0615 (631-234-0500; FAX: 631-234-0691; www.mixers.com)

Dryers, vacuum

PAUL O. ABBE, 201 Hanson Ct. Suite 125, Wood Dale, IL 60191 (630-350-3012; FAX: 630-238-7584)
—See our ad on page 15

B&P LITTLEFORD, 1000 Hess Avenue, Saginaw, MI 48601 (989-757-1300; FAX: 989-757-1301; www.bplittleford.com)

BUSS-SMS-CANZLER GMBH, Kaiserstr. 13-15, Butzbach, Germany 35510 (49-6033-85-0; FAX: 49-6033-85-249)

CROLL REYNOLDS CO. INC., Six Campus Drive, Parsippany, NJ 07054 (908-232-4200; FAX: 908-232-2146; info@croll.com; www.croll.com)

EKATO RUEHR- UND MISCHTECHNIK GMBH, Hohe-Flum-Str.37, Schopfheim, Germany D-79650 (+49 7622 290; FAX: + 49 7622 29 213; www.ekato.com)
—See our ad on page 84

FLUID LINE PRODUCTS INC., 38273 Western Pkwy., P.O. Box 1000, Willoughby, OH 44096 (440-946-9470; FAX: 440-946-9472; www.fluidline.com)

GEMCO, the worldwide mixing and drying authority, Middlesex, NJ

JAYGO, INC., 7 Emery Ave., Randolph, NJ 07869 (908-688-3600; FAX: 908-688-6060)

POPE SCIENTIFIC, INC., P.O. Box 80018, 351 N. Dekora Woods Blvd., Saukville, WI 53080 (262-268-9300; FAX: 262-268-9400; info@popeinc.com; www.popeinc.com)

ROSS MIXERS, 710 Old Willets Path, P.O. Box 12308, Hauppauge, NY 11788-0615 (631-234-0500; FAX: 631-234-0691; www.mixers.com)

Dryers, vertical

PAUL O. ABBE, 201 Hanson Ct. Suite 125, Wood Dale, IL 60191 (630-350-3012; FAX: 630-238-7584)
—See our ad on page 15

BUSS-SMS-CANZLER GMBH, Kaiserstr. 13-15, Butzbach, Germany 35510 (49-6033-85-0; FAX: 49-6033-85-249)

EKATO RUEHR- UND MISCHTECHNIK GMBH, Hohe-Flum-Str.37, Schopfheim, Germany D-79650 (+49 7622 290; FAX: + 49 7622 29 213; www.ekato.com)
—See our ad on page 84

FLUID LINE PRODUCTS INC., 38273 Western Pkwy., P.O. Box 1000, Willoughby, OH 44096 (440-946-9470; FAX: 440-946-9472; www.fluidline.com)

JAYGO, INC., 7 Emery Ave., Randolph, NJ 07869 (908-688-3600; FAX: 908-688-6060)

ROSS MIXERS, 710 Old Willets Path, P.O. Box 12308, Hauppauge, NY 11788-0615 (631-234-0500; FAX: 631-234-0691; www.mixers.com)

Dryers, vibrating

COMESSA, Strasbourg, France

DUST COLLECTORS & SEPARATORS

Baghouses

SCHENCK PROCESS, 7901 NW 107th Terrace, Kansas City, MO 64153 (816-891-9300; FAX: 816-891-8336; www.schenckprocess.com)

Dust collector parts & accessories

AUTOMATION PRODUCTS INC. (DYNATROL DIV.), 3030 Maxroy St., Houston, TX 77008 (713-869-0361; FAX: 713-869-7332; sales@dynamatrolusa.com; www.dynamatrolusa.com)

HAPMAN, 6002 East N Avenue, Kalamazoo, MI 49048 (269-343-1675; FAX: 269-349-2477; sales@hapman.com; www.hapman.com)

SCHENCK PROCESS, 7901 NW 107th Terrace, Kansas City, MO 64153 (816-891-9300; FAX: 816-891-8336; www.schenckprocess.com)

Dust collectors, bag filtering

GEA GROUP, 9165 Rumsey Road, Columbia, MD 21045 (800-722-6622; www.gea.com)
— See our ad on page 23

SCHENCK PROCESS, 7901 NW 107th Terrace, Kansas City, MO 64153 (816-891-9300; FAX: 816-891-8336; www.schenckprocess.com)

Dust collectors, cartridge

DYNAMIC AIR INC., 1125 Willow Lake Blvd., St. Paul, MN 55110-5193 (651-484-2900; FAX: 651-484-7015; www.dynamicair.com)

HAPMAN, 6002 East N Avenue, Kalamazoo, MI 49048 (269-343-1675; FAX: 269-349-2477; sales@hapman.com; www.hapman.com)

SCHENCK PROCESS, 7901 NW 107th Terrace, Kansas City, MO 64153 (816-891-9300; FAX: 816-891-8336; www.schenckprocess.com)

Dust collectors, cyclone

Pacific Dust Collectors & Equipment, Damascus, OR
SCHENCK PROCESS, 7901 NW 107th Terrace, Kansas City, MO 64153 (816-891-9300; FAX: 816-891-8336; www.schenckprocess.com)

Dust collectors, electrostatic precipitators

BELTRAN TECHNOLOGIES, INC., 1133 East 35 Street, Brooklyn, NY 11210 (718-338-3311; FAX: 718-253-9028; info@beltrantechnologies.com; www.beltran-technologies.com)

GEA GROUP, 9165 Rumsey Road, Columbia, MD 21045 (800-722-6622; www.gea.com)
— See our ad on page 23

Dust collectors, other

SCHENCK PROCESS, 7901 NW 107th Terrace, Kansas City, MO 64153 (816-891-9300; FAX: 816-891-8336; www.schenckprocess.com)

Dust collectors, pulse jet

GEA GROUP, 9165 Rumsey Road, Columbia, MD 21045 (800-722-6622; www.gea.com)
— See our ad on page 23

HAPMAN, 6002 East N Avenue, Kalamazoo, MI 49048 (269-343-1675; FAX: 269-349-2477; sales@hapman.com; www.hapman.com)

SCHENCK PROCESS, 7901 NW 107th Terrace, Kansas City, MO 64153 (816-891-9300; FAX: 816-891-8336; www.schenckprocess.com)

Dust collectors, wet

GEA GROUP, 9165 Rumsey Road, Columbia, MD 21045 (800-722-6622; www.gea.com)
— See our ad on page 23

Dust removal equipment

SCHENCK PROCESS, 7901 NW 107th Terrace, Kansas City, MO 64153 (816-891-9300; FAX: 816-891-8336; www.schenckprocess.com)

ELECTROCHEMICAL EQUIPMENT

Electrodes: anodes & cathodes

INEOS Electrochemical Solutions, Runcorn, Cheshire, United Kingdom

Electrolytic cells

INEOS Electrochemical Solutions, Runcorn, Cheshire, United Kingdom

THYSSENKRUPP INDUSTRIAL SOLUTIONS AG, thyssenkrupp Allee 1, Essen, Germany 45143 (49-201 8440; info.industrial-solutions@thyssenkrupp.com; www.thyssenkrupp-industrial-solutions.com)

ENTRAINMENT SEPARATION EQUIPMENT

Defoamers, physical

EKATO RUEHR- UND MISCHTECHNIK GMBH, Hohe-Flum-Str.37, Schopfheim, Germany D-79650 (+49 7622 290; FAX: + 49 7622 29 213; www.ekato.com)
— See our ad on page 84

FLUID LINE PRODUCTS INC., 38273 Western Pkwy., P.O. Box 1000, Willoughby, OH 44096 (440-946-9470; FAX: 440-946-9472; www.fluidline.com)

JAYGO, INC., 7 Emery Ave., Randolph, NJ 07869 (908-688-3600; FAX: 908-688-6060)

Mist eliminators

KOCH-GLITSCH, INC., 4111 E. 37th St. N., Wichita, KS 67220 (316-828-5110; FAX: 316-828-7985)
— See our ad inside front cover

Pentair, Conroe, TX

Traps, air

TLV CORPORATION, 13901 S. Lakes Dr., Charlotte, NC 28273 (704-597-9070; FAX: 704-583-1610; www.tlv.com)
— See our ad on page 65

EVAPORATORS & CRYSTALLIZERS

Crystallizers, cooling

AAHANA Giffard Systems, Mannheim., Baden-Württemberg, Germany

GEA GROUP, 9165 Rumsey Road, Columbia, MD 21045 (800-722-6622; www.gea.com)
— See our ad on page 23

Crystallizers, evaporative

DEDERT CORPORATION, 17740 Hoffman way, Homewood, IL 60430 (708-747-7000; c.crankshaw@dedert.com; www.dedert.com)

GEA GROUP, 9165 Rumsey Road, Columbia, MD 21045 (800-722-6622; www.gea.com)
— See our ad on page 23

Crystallizers, freeze

GEA GROUP, 9165 Rumsey Road, Columbia, MD 21045 (800-722-6622; www.gea.com)
— See our ad on page 23

SULZER CHEMTECH, Neuwiesenstrasse 15, Winterthur, Switzerland 8401 (41522623722; www.sulzer.com)

Crystallizers, melt

GEA GROUP, 9165 Rumsey Road, Columbia, MD 21045 (800-722-6622; www.gea.com)
— See our ad on page 23

Crystallizers, scraped surface

EKATO RUEHR- UND MISCHTECHNIK GMBH, Hohe-Flum-Str.37, Schopfheim, Germany D-79650 (+49 7622 290; FAX: + 49 7622 29 213; www.ekato.com)
— See our ad on page 84

FLUID LINE PRODUCTS INC., 38273 Western Pkwy., P.O. Box 1000, Willoughby, OH 44096 (440-946-9470; FAX: 440-946-9472; www.fluidline.com)

GEA GROUP, 9165 Rumsey Road, Columbia, MD 21045 (800-722-6622; www.gea.com)
— See our ad on page 23

Crystallizers, vacuum

CROLL REYNOLDS CO. INC., Six Campus Drive, Parsippany, NJ 07054 (908-232-4200; FAX: 908-232-2146; info@croll.com; www.croll.com)

EKATO RUEHR- UND MISCHTECHNIK GMBH, Hohe-Flum-Str.37, Schopfheim, Germany D-79650 (+49 7622 290; FAX: + 49 7622 29 213; www.ekato.com)
— See our ad on page 84

FLUID LINE PRODUCTS INC., 38273 Western Pkwy., P.O. Box 1000, Willoughby, OH 44096 (440-946-9470; FAX: 440-946-9472; www.fluidline.com)

GEA GROUP, 9165 Rumsey Road, Columbia, MD 21045 (800-722-6622; www.gea.com)
— See our ad on page 23

Evaporative systems, mechanical recompression

DEDERT CORPORATION, 17740 Hoffman way, Homewood, IL 60430 (708-747-7000; c.crankshaw@dedert.com; www.dedert.com)

GEA GROUP, 9165 Rumsey Road, Columbia, MD 21045 (800-722-6622; www.gea.com)
— See our ad on page 23

Evaporative systems, multiple effect

BUSS-SMS-CANZLER GMBH, Kaiserstr. 13-15, Butzbach, Germany 35510 (49-6033-85-0; FAX: 49-6033-85-249)

DEDERT CORPORATION, 17740 Hoffman way, Homewood, IL 60430 (708-747-7000; c.crankshaw@dedert.com; www.dedert.com)

GEA GROUP, 9165 Rumsey Road, Columbia, MD 21045 (800-722-6622; www.gea.com)
— See our ad on page 23

KOERTING HANNOVER GMBH, Badenstedter Str. 56, Hannover, Germany 30453 (0511-2129-0; FAX: 0511-2129-223)
— See our ad on page 69

Evaporative systems, thermal recompression

CROLL REYNOLDS PROCESS VACUUM

CROLL REYNOLDS CO. INC., Six Campus Drive, Parsippany, NJ 07054 (908-232-4200; FAX: 908-232-2146; info@croll.com; www.croll.com)

DEDERT CORPORATION, 17740 Hoffman way, Homewood, IL 60430 (708-747-7000; c.crankshaw@dedert.com; www.dedert.com)

GEA GROUP, 9165 Rumsey Road, Columbia, MD 21045 (800-722-6622; www.gea.com)
— See our ad on page 23

KOERTING HANNOVER GMBH, Badenstedter Str. 56, Hannover, Germany 30453 (0511-2129-0; FAX: 0511-2129-223)
— See our ad on page 69

Evaporators, agitated film

BUSS-SMS-CANZLER GMBH, Kaiserstr. 13-15, Butzbach, Germany 35510 (49-6033-85-0; FAX: 49-6033-85-249)

GEA GROUP, 9165 Rumsey Road, Columbia, MD 21045 (800-722-6622; www.gea.com)
— See our ad on page 23

JLS INTERNATIONAL, INC., 381 Fawn Lane, West Jefferson, NC 28694 (336-877-5571; FAX: 336-877-5579)

POPE SCIENTIFIC, INC., P.O. Box 80018, 351 N. Dekora Woods Blvd., Saukville, WI 53080 (262-268-9300; FAX: 262-268-9400; info@popeinc.com; www.popeinc.com)

Evaporators, climbing film

GEA GROUP, 9165 Rumsey Road, Columbia, MD 21045 (800-722-6622; www.gea.com)
— See our ad on page 23

Evaporators, falling film

AAHANA Giffard Systems, Mannheim., Baden-Württemberg, Germany

BUSS-SMS-CANZLER GMBH, Kaiserstr. 13-15, Butzbach, Germany 35510 (49-6033-85-0; FAX: 49-6033-85-249)

GEA GROUP, 9165 Rumsey Road, Columbia, MD 21045 (800-722-6622; www.gea.com)
— See our ad on page 23

POPE SCIENTIFIC, INC., P.O. Box 80018, 351 N. Dekora Woods Blvd., Saukville, WI 53080 (262-268-9300; FAX: 262-268-9400; info@popeinc.com; www.popeinc.com)

Evaporators, flash

GEA GROUP, 9165 Rumsey Road, Columbia, MD 21045 (800-722-6622; www.gea.com)
— See our ad on page 23

KOERTING HANNOVER GMBH, Badenstedter Str. 56, Hannover, Germany 30453 (0511-2129-0; FAX: 0511-2129-223)
— See our ad on page 69

POPE SCIENTIFIC, INC., P.O. Box 80018, 351 N. Dekora Woods Blvd., Saukville, WI 53080 (262-268-9300; FAX: 262-268-9400; info@popeinc.com; www.popeinc.com)

Evaporators, forced circulation

DEDERT CORPORATION, 17740 Hoffman way, Homewood, IL 60430 (708-747-7000; c.crankshaw@dedert.com; www.dedert.com)

GEA GROUP, 9165 Rumsey Road, Columbia, MD 21045
(800-722-6622; www.gea.com)
—See our ad on page 23
Kelvion, Bochum, Germany

Evaporators, horizontal tube

GEA GROUP, 9165 Rumsey Road, Columbia, MD 21045
(800-722-6622; www.gea.com)
—See our ad on page 23

Evaporators, low temperature

GEA GROUP, 9165 Rumsey Road, Columbia, MD 21045
(800-722-6622; www.gea.com)
—See our ad on page 23

POPE SCIENTIFIC, INC., P.O. Box 80018, 351 N. Dekora Woods Blvd., Saukville, WI 53080 (262-268-9300; FAX: 262-268-9400; info@popeinc.com; www.popeinc.com)

Evaporators, plate type

GEA GROUP, 9165 Rumsey Road, Columbia, MD 21045
(800-722-6622; www.gea.com)
—See our ad on page 23

Kelvion, Bochum, Germany

Evaporators, short path

BUSS-SMS-CANZLER GMBH, Kaiserstr. 13-15, Butzbach, Germany 35510 (49-6033-85-0; FAX: 49-6033-85-249)

JLS INTERNATIONAL, INC., 381 Fawn Lane, West Jefferson, NC 28694 (336-877-5571; FAX: 336-877-5579)

POPE SCIENTIFIC, INC., P.O. Box 80018, 351 N. Dekora Woods Blvd., Saukville, WI 53080 (262-268-9300; FAX: 262-268-9400; info@popeinc.com; www.popeinc.com)

Evaporators, thin film

BUSS-SMS-CANZLER GMBH, Kaiserstr. 13-15, Butzbach, Germany 35510 (49-6033-85-0; FAX: 49-6033-85-249)

JLS INTERNATIONAL, INC., 381 Fawn Lane, West Jefferson, NC 28694 (336-877-5571; FAX: 336-877-5579)

POPE SCIENTIFIC, INC., P.O. Box 80018, 351 N. Dekora Woods Blvd., Saukville, WI 53080 (262-268-9300; FAX: 262-268-9400; info@popeinc.com; www.popeinc.com)

Evaporators, vertical long tube

GEA GROUP, 9165 Rumsey Road, Columbia, MD 21045
(800-722-6622; www.gea.com)
—See our ad on page 23

Evaporators, waste water

BUSS-SMS-CANZLER GMBH, Kaiserstr. 13-15, Butzbach, Germany 35510 (49-6033-85-0; FAX: 49-6033-85-249)

Caloris Engineering, Easton, MD

GEA GROUP, 9165 Rumsey Road, Columbia, MD 21045
(800-722-6622; www.gea.com)
—See our ad on page 23

Evaporators, wiped film

BUSS-SMS-CANZLER GMBH, Kaiserstr. 13-15, Butzbach, Germany 35510 (49-6033-85-0; FAX: 49-6033-85-249)

JLS INTERNATIONAL, INC., 381 Fawn Lane, West Jefferson, NC 28694 (336-877-5571; FAX: 336-877-5579)

POPE SCIENTIFIC, INC., P.O. Box 80018, 351 N. Dekora Woods Blvd., Saukville, WI 53080 (262-268-9300; FAX: 262-268-9400; info@popeinc.com; www.popeinc.com)

FILTER MEDIA & AIDS

Felt, filter

Filtration Technology Corporation, Houston, TX

Filter bags, acidproof

Filtration Technology Corporation, Houston, TX

Filter bags, alkaliproof

Filtration Technology Corporation, Houston, TX

Filter bags, glass

Filtration Technology Corporation, Houston, TX

Filter bags, natural fiber

Filtration Technology Corporation, Houston, TX

Filter bags, synthetic fiber

Filtration Technology Corporation, Houston, TX

Filter media, other

ANDRITZ SEPARATION, ANDRITZ AG, Stattegger Strasse 18, Graz, Austria 8045 (+43 050 8050; separation@andritz.com; www.andritz.com/separation)
Filtration Technology Corporation, Houston, TX

Paper, filter

Filtration Technology Corporation, Houston, TX

Plates, filter

ANDRITZ SEPARATION, ANDRITZ AG, Stattegger Strasse 18, Graz, Austria 8045 (+43 050 8050; separation@andritz.com; www.andritz.com/separation)

FILTRATION EQUIPMENT

Dewatering, mechanical press

ANDRITZ SEPARATION, ANDRITZ AG, Stattegger Strasse 18, Graz, Austria 8045 (+43 050 8050; separation@andritz.com; www.andritz.com/separation)

METSO MINERALS INDUSTRIES, INC., 2715 Pleasant Valley Road, York, PA 17402 (717-843-8671; FAX: 717-845-5154; www.metso.com)
—See our ad on page 39

Filter housings

Filtration Technology Corporation, Houston, TX

JLS INTERNATIONAL, INC., 381 Fawn Lane, West Jefferson, NC 28694 (336-877-5571; FAX: 336-877-5579)
PRM Filtration, Raleigh, NC

Filter parts & accessories

ANDRITZ SEPARATION, ANDRITZ AG, Stattegger Strasse 18, Graz, Austria 8045 (+43 050 8050; separation@andritz.com; www.andritz.com/separation)

Orival Water Filters, Englewood, NJ

SAP FILTER PVT LTD, Mumbai, Maharashtra, India

Filter presses

ANDRITZ SEPARATION, ANDRITZ AG, Stattegger Strasse 18, Graz, Austria 8045 (+43 050 8050; separation@andritz.com; www.andritz.com/separation)

Filter systems

ANDRITZ SEPARATION, ANDRITZ AG, Stattegger Strasse 18, Graz, Austria 8045 (+43 050 8050; separation@andritz.com; www.andritz.com/separation)

Filtration Technology Corporation, Houston, TX

Orival Water Filters, Englewood, NJ

PRM Filtration, Raleigh, NC

SAP FILTER PVT LTD, Mumbai, Maharashtra, India

Filters, activated carbon

SAP FILTER PVT LTD, Mumbai, Maharashtra, India

Filters, air

SCHENCK PROCESS, 7901 NW 107th Terrace, Kansas City, MO 64153 (816-891-9300; FAX: 816-891-8336; www.schenckprocess.com)

Filters, bag

Filtration Technology Corporation, Houston, TX

PRM Filtration, Raleigh, NC

SAP FILTER PVT LTD, Mumbai, Maharashtra, India

SCHENCK PROCESS, 7901 NW 107th Terrace, Kansas City, MO 64153 (816-891-9300; FAX: 816-891-8336; www.schenckprocess.com)

Filters, belt

ANDRITZ SEPARATION, ANDRITZ AG, Stattegger Strasse 18, Graz, Austria 8045 (+43 050 8050; separation@andritz.com; www.andritz.com/separation)

Filters, cartridge

Filtration Technology Corporation, Houston, TX

PRM Filtration, Raleigh, NC

SAP FILTER PVT LTD, Mumbai, Maharashtra, India

SCHENCK PROCESS, 7901 NW 107th Terrace, Kansas City, MO 64153 (816-891-9300; FAX: 816-891-8336; www.schenckprocess.com)

Filters, crossflow

ANDRITZ SEPARATION, ANDRITZ AG, Stattegger Strasse 18, Graz, Austria 8045 (+43 050 8050; separation@andritz.com; www.andritz.com/separation)

Filters, disc, pressure

ANDRITZ SEPARATION, ANDRITZ AG, Stattegger Strasse 18, Graz, Austria 8045 (+43 050 8050; separation@andritz.com; www.andritz.com/separation)

Filters, disc, vacuum

ANDRITZ SEPARATION, ANDRITZ AG, Stattegger Strasse 18, Graz, Austria 8045 (+43 050 8050; separation@andritz.com; www.andritz.com/separation)

Filters, drum, rotary pressure continuous

ANDRITZ SEPARATION, ANDRITZ AG, Stattegger Strasse 18, Graz, Austria 8045 (+43 050 8050; separation@andritz.com; www.andritz.com/separation)

Filters, gas

Filtration Technology Corporation, Houston, TX

Filters, horizontal belt, vacuum

ANDRITZ SEPARATION, ANDRITZ AG, Stattegger Strasse 18, Graz, Austria 8045 (+43 050 8050; separation@andritz.com; www.andritz.com/separation)

Filters, leaf, horizontal, pressure

ANDRITZ SEPARATION, ANDRITZ AG, Stattegger Strasse 18, Graz, Austria 8045 (+43 050 8050; separation@andritz.com; www.andritz.com/separation)

Filters, leaf, vacuum

ANDRITZ SEPARATION, ANDRITZ AG, Stattegger Strasse 18, Graz, Austria 8045 (+43 050 8050; separation@andritz.com; www.andritz.com/separation)

Filters, leaf, vertical, pressure

ANDRITZ SEPARATION, ANDRITZ AG, Stattegger Strasse 18, Graz, Austria 8045 (+43 050 8050; separation@andritz.com; www.andritz.com/separation)

Filters, membrane

ANDRITZ SEPARATION, ANDRITZ AG, Stattegger Strasse 18, Graz, Austria 8045 (+43 050 8050; separation@andritz.com; www.andritz.com/separation)

Caloris Engineering, Easton, MD

GEA GROUP, 9165 Rumsey Road, Columbia, MD 21045
(800-722-6622; www.gea.com)
—See our ad on page 23

SARTORIUS - CHEMICAL & CONSUMER CARE, Otto-Brenner-Straße 20, Goettingen, Germany 37079 (+49-(0)551 3084756; www.sartorius.com/chemicals)
Toray Membrane USA, Inc.

Filters, microfiltration

Filtration Technology Corporation, Houston, TX

GEA GROUP, 9165 Rumsey Road, Columbia, MD 21045
(800-722-6622; www.gea.com)
—See our ad on page 23

Orival Water Filters, Englewood, NJ

Toray Membrane USA, Inc.

Filters, nanofiltration

GEA GROUP, 9165 Rumsey Road, Columbia, MD 21045
(800-722-6622; www.gea.com)
—See our ad on page 23

Toray Membrane USA, Inc.

Filters, nutsche

Buchiglas USA Corp., Farmingdale, NY

JAYGO, INC., 7 Emery Ave., Randolph, NJ 07869 (908-688-3600; FAX: 908-688-6060)

POPE SCIENTIFIC, INC., P.O. Box 80018, 351 N. Dekora Woods Blvd., Saukville, WI 53080 (262-268-9300; FAX: 262-268-9400; info@popeinc.com; www.popeinc.com)

Filters, oil removal

Filtration Technology Corporation, Houston, TX

KOCH-GLITSCH, INC., 4111 E. 37th St. N., Wichita, KS

67220 (316-828-5110; FAX: 316-828-7985)

—See our ad inside front cover

Filters, pan

ANDRITZ SEPARATION, ANDRITZ AG, Stattegger Strasse 18, Graz, Austria 8045 (+43 050 8050; separation@andritz.com; www.andritz.com/separation)

Filters, pipeline

Filtration Technology Corporation, Houston, TX

Orival Water Filters, Englewood, NJ

Filters, plate & frame

ANDRITZ SEPARATION, ANDRITZ AG, Stattegger Strasse 18, Graz, Austria 8045 (+43 050 8050; separation@andritz.com; www.andritz.com/separation)

Filters, porous metal

ACS Industries Inc., Lincoln, RI

JAYGO, INC., 7 Emery Ave., Randolph, NJ 07869 (908-688-3600; FAX: 908-688-6060)

Filters, portable

Filtration Technology Corporation, Houston, TX

Filters, sand

Orival Water Filters, Englewood, NJ

Filters, ultrafiltration

GEA GROUP, 9165 Rumsey Road, Columbia, MD 21045 (800-722-6622; www.gea.com)

— See our ad on page 23

SARTORIUS - CHEMICAL & CONSUMER CARE, Otto-Brenner-Straße 20, Goettingen, Germany 37079 (+49-0)511 3084756; www.sartorius.com/chemicals)
Toray Membrane USA, Inc.

Filters, water

Filtration Technology Corporation, Houston, TX
KOCH-GLITSCH, INC., 4111 E. 37th St. N., Wichita, KS 67220 (316-828-5110; FAX: 316-828-7985)

— See our ad inside front cover

PRM Filtration, Raleigh, NC

Microfiltration equipment

Filtration Technology Corporation, Houston, TX

Screw presses

ANDRITZ SEPARATION, ANDRITZ AG, Stattegger Strasse 18, Graz, Austria 8045 (+43 050 8050; separation@andritz.com; www.andritz.com/separation)

HEAT EXCHANGERS, CONDENSERS & COOLERS

Aftercoolers

XCHANGER, INC., 1401 S. 7th St., Hopkins, MN 55343 (952-933-2559; www.xchanger.com)

Condensate return systems

HRS Process Systems Ltd., Pune, India
TLV CORPORATION, 13901 S. Lakes Dr., Charlotte, NC 28273 (704-597-9070; FAX: 704-583-1610; www.tlv.com)

— See our ad on page 65

XCHANGER, INC., 1401 S. 7th St., Hopkins, MN 55343 (952-933-2559; www.xchanger.com)

Condensers, air cooled

XCHANGER, INC., 1401 S. 7th St., Hopkins, MN 55343 (952-933-2559; www.xchanger.com)

Condensers, barometric

CROLL REYNOLDS CO. INC., Six Campus Drive, Parsippany, NJ 07054 (908-232-4200; FAX: 908-232-2146; info@croll.com; www.croll.com)

KOERTING HANNOVER GMBH, Badenstedter Str. 56, Hannover, Germany 30453 (0511-2129-0; FAX: 0511-2129-223)

— See our ad on page 69

Condensers, coil

Kelvion, Bochum, Germany

Condensers, evaporative refrigerant

GEA GROUP, 9165 Rumsey Road, Columbia, MD 21045 (800-722-6622; www.gea.com)

— See our ad on page 23

Kelvion, Bochum, Germany

Condensers, jet ejector

CROLL REYNOLDS CO. INC., Six Campus Drive, Parsippany, NJ 07054 (908-232-4200; FAX: 908-232-2146; info@croll.com; www.croll.com)

GEA GROUP, 9165 Rumsey Road, Columbia, MD 21045 (800-722-6622; www.gea.com)

— See our ad on page 23

HRS Process Systems Ltd., Pune, India

JLS INTERNATIONAL, INC., 381 Fawn Lane, West Jefferson, NC 28694 (336-877-5571; FAX: 336-877-5579)

KOERTING HANNOVER GMBH, Badenstedter Str. 56, Hannover, Germany 30453 (0511-2129-0; FAX: 0511-2129-223)

— See our ad on page 69

Condensers, reflux

HRS Process Systems Ltd., Pune, India

Condensers, shell & tube

CROLL REYNOLDS CO. INC., Six Campus Drive, Parsippany, NJ 07054 (908-232-4200; FAX: 908-232-2146; info@croll.com; www.croll.com)

GEA GROUP, 9165 Rumsey Road, Columbia, MD 21045 (800-722-6622; www.gea.com)

— See our ad on page 23

HRS Process Systems Ltd., Pune, India

JLS INTERNATIONAL, INC., 381 Fawn Lane, West Jefferson, NC 28694 (336-877-5571; FAX: 336-877-5579)

KOERTING HANNOVER GMBH, Badenstedter Str. 56, Hannover, Germany 30453 (0511-2129-0; FAX: 0511-2129-223)

— See our ad on page 69

Quickly Prepare, Plug And Repair Leaking Heat Exchanger, Condenser and Boiler Tubes

Condensers, steam

CROLL REYNOLDS CO. INC., Six Campus Drive, Parsippany, NJ 07054 (908-232-4200; FAX: 908-232-2146; info@croll.com; www.croll.com)

HRS Process Systems Ltd., Pune, India

KOERTING HANNOVER GMBH, Badenstedter Str. 56, Hannover, Germany 30453 (0511-2129-0; FAX: 0511-2129-223)

— See our ad on page 69

XCHANGER, INC., 1401 S. 7th St., Hopkins, MN 55343 (952-933-2559; www.xchanger.com)

Condensers, surface

CROLL REYNOLDS CO. INC., Six Campus Drive, Parsippany, NJ 07054 (908-232-4200; FAX: 908-232-2146; info@croll.com; www.croll.com)

JLS INTERNATIONAL, INC., 381 Fawn Lane, West Jefferson, NC 28694 (336-877-5571; FAX: 336-877-5579)

KOERTING HANNOVER GMBH, Badenstedter Str. 56, Hannover, Germany 30453 (0511-2129-0; FAX: 0511-2129-223)

— See our ad on page 69

Condensers, tubular

JLS INTERNATIONAL, INC., 381 Fawn Lane, West Jefferson, NC 28694 (336-877-5571; FAX: 336-877-5579)

Condensers, vapor

KOERTING HANNOVER GMBH, Badenstedter Str. 56, Hannover, Germany 30453 (0511-2129-0; FAX: 0511-2129-223)

— See our ad on page 69

XCHANGER, INC., 1401 S. 7th St., Hopkins, MN 55343 (952-933-2559; www.xchanger.com)

Coolers, air cooled

XCHANGER, INC., 1401 S. 7th St., Hopkins, MN 55343 (952-933-2559; www.xchanger.com)

Coolers, belt

AMANDUS KAHL GmbH & Co. KG, Reinbek, Germany
BERNDORF BAND GROUP, Leobersdorferstr. 26, Berndorf, Austria 2560 (43-2672-800-0; FAX: 43-2672-84176; www.berndorfband-group.com)

IPCO GERMANY GMBH, Salierstr. 35, Fellbach, Germany 70736 (+49 711 5105 0)

Coolers, closed circuit

AMANDUS KAHL GmbH & Co. KG, Reinbek, Germany

Coolers, coil

SENTRY EQUIPMENT CORP, 966 Blue Ribbon Circle North, Oconomowoc, WI 53066 (262-567-7256; FAX: 262-567-4523)

Coolers, evaporative

CROLL REYNOLDS CO. INC., Six Campus Drive, Parsippany, NJ 07054 (908-232-4200; FAX: 908-232-2146; info@croll.com; www.croll.com)

Coolers, finned tube

FIN TUBE PRODUCTS, INC., 188 S Lyman St., Suite 100, Wadsworth, OH 44281 (330-334-3736; FAX: 330-334-3848; mb@fintube.com; www.fintube.com)

XCHANGER, INC., 1401 S. 7th St., Hopkins, MN 55343 (952-933-2559; www.xchanger.com)

Coolers, flash

CROLL REYNOLDS CO. INC., Six Campus Drive, Parsippany, NJ 07054 (908-232-4200; FAX: 908-232-2146; info@croll.com; www.croll.com)

Coolers, screw

ANDRITZ SEPARATION, ANDRITZ AG, Stattegger Strasse 18, Graz, Austria 8045 (+43 050 8050; separation@andritz.com; www.andritz.com/separation)

Coolers, water

SENTRY EQUIPMENT CORP, 966 Blue Ribbon Circle North, Oconomowoc, WI 53066 (262-567-7256; FAX: 262-567-4523)

Desuperheaters

CROLL REYNOLDS
PROCESS VACUUM

CROLL REYNOLDS CO. INC., Six Campus Drive, Parsippany, NJ 07054 (908-232-4200; FAX: 908-232-2146; info@croll.com; www.croll.com)

JLS INTERNATIONAL, INC., 381 Fawn Lane, West Jefferson, NC 28694 (336-877-5571; FAX: 336-877-5579)

Economizers

INDECK POWER EQUIPMENT CO., 1111 Willis Ave. (CE), Wheeling, IL 60090 (847-541-8300; FAX: 847-541-9984; www.indeck.com)

— See our ad on page 15

Heat exchanger parts & accessories

FIN TUBE PRODUCTS, INC., 188 S Lyman St., Suite 100, Wadsworth, OH 44281 (330-334-3736; FAX: 330-334-3848; mb@fintube.com; www.fintube.com)

Quickly Prepare, Plug And Repair Leaking Heat Exchanger, Condenser and Boiler Tubes

TLV CORPORATION, 13901 S. Lakes Dr., Charlotte, NC 28273 (704-597-9070; FAX: 704-583-1610; www.tlv.com)

— See our ad on page 65

Heat exchangers, air cooled

XCHANGER, INC., 1401 S. 7th St., Hopkins, MN 55343 (952-933-2559; www.xchanger.com)

Heat exchangers, all-welded

JLS INTERNATIONAL, INC., 381 Fawn Lane, West Jefferson, NC 28694 (336-877-5571; FAX: 336-877-5579)

Heat exchangers, cascade

GEA GROUP, 9165 Rumsey Road, Columbia, MD 21045 (800-722-6622; www.gea.com)

— See our ad on page 23

Heat exchangers, coil

CAST-X Circulation Heaters, Batavia, IL
SENTRY EQUIPMENT CORP, 966 Blue Ribbon Circle North, Oconomowoc, WI 53066 (262-567-7256; FAX: 262-567-4523)

Heat exchangers, direct contact steam

CROLL REYNOLDS CO. INC., Six Campus Drive, Parsippany, NJ 07054 (908-232-4200; FAX: 908-232-2146; info@croll.com; www.croll.com)

KOERTING HANNOVER GMBH, Badenstedter Str. 56, Hannover, Germany 30453 (0511-2129-0; FAX: 0511-2129-223)

— See our ad on page 69

PICK HEATERS INC., 730 S. Indiana Ave., P.O. Box 516, West Bend, WI 53095 (262-338-1191; FAX: 262-338-8489; www.pickheaters.com)

Heat exchangers, double pipe

CAST-X Circulation Heaters, Batavia, IL
JLS INTERNATIONAL, INC., 381 Fawn Lane, West Jefferson, NC 28694 (336-877-5571; FAX: 336-877-5579)

Heat exchangers, finned tube

FIN TUBE PRODUCTS, INC., 188 S Lyman St., Suite 100, Wadsworth, OH 44281 (330-334-3736; FAX: 330-334-3848; mb@fintube.com; www.fintube.com)

XCHANGER, INC., 1401 S. 7th St., Hopkins, MN 55343 (952-933-2559; www.xchanger.com)

Heat exchangers, plate

INDECK POWER EQUIPMENT CO., 1111 Willis Ave. (CE), Wheeling, IL 60090 (847-541-8300; FAX: 847-541-9984; www.indeck.com)

— See our ad on page 15

Heat exchangers, plate fin

XCHANGER, INC., 1401 S. 7th St., Hopkins, MN 55343 (952-933-2559; www.xchanger.com)

Heat exchangers, PTFE tube

CAST-X Circulation Heaters, Batavia, IL
SENTRY EQUIPMENT CORP, 966 Blue Ribbon Circle North, Oconomowoc, WI 53066 (262-567-7256; FAX: 262-567-4523)

Heat exchangers, scraped surface

BUSS-SMS-CANZLER GMBH, Kaiserstr. 13-15, Butzbach, Germany 35510 (49-6033-85-0; FAX: 49-6033-85-249)

Heat exchangers, screw flight

METSO MINERALS INDUSTRIES, INC., 2715 Pleasant Valley Road, York, PA 17402 (717-843-8671; FAX: 717-845-5154; www.metso.com)

— See our ad on page 39

Heat exchangers, shell & tube

CAST-X Circulation Heaters, Batavia, IL
CROLL REYNOLDS CO. INC., Six Campus Drive, Parsippany, NJ 07054 (908-232-4200; FAX: 908-232-2146; info@croll.com; www.croll.com)

GEA GROUP, 9165 Rumsey Road, Columbia, MD 21045 (800-722-6622; www.gea.com)

— See our ad on page 23

JLS INTERNATIONAL, INC., 381 Fawn Lane, West Jefferson, NC 28694 (336-877-5571; FAX: 336-877-5579)

Heat exchangers, spiral

CAST-X Circulation Heaters, Batavia, IL
FIN TUBE PRODUCTS, INC., 188 S Lyman St., Suite 100, Wadsworth, OH 44281 (330-334-3736; FAX: 330-334-3848; mb@fintube.com; www.fintube.com)
SENTRY EQUIPMENT CORP., 966 Blue Ribbon Circle North, Oconomowoc, WI 53066 (262-567-7256; FAX: 262-567-4523)

Heat exchangers, titanium

JLS INTERNATIONAL, INC., 381 Fawn Lane, West Jefferson, NC 28694 (336-877-5571; FAX: 336-877-5579)

Heat exchangers, U tube

CROLL REYNOLDS CO. INC., Six Campus Drive, Parsippany, NJ 07054 (908-232-4200; FAX: 908-232-2146; info@croll.com; www.croll.com)
 JLS INTERNATIONAL, INC., 381 Fawn Lane, West Jefferson, NC 28694 (336-877-5571; FAX: 336-877-5579)

Heat exchangers, zirconium

JLS INTERNATIONAL, INC., 381 Fawn Lane, West Jefferson, NC 28694 (336-877-5571; FAX: 336-877-5579)

Heat transfer systems

CAST-X Circulation Heaters, Batavia, IL
 Thermal Care, Niles, IL
 Thermal Fluid Systems Inc., Kennesaw, GA
UNIFLUX / EXOTHERM CORP., 31369 Nichols Sawmill Road, Magnolia, TX 77355 (713-981-9100; FAX: 713-981-7081; info@exotherm.com; www.exotherm.com)
 — See our ad on page 57

Heaters, process liquid

CAST-X Circulation Heaters, Batavia, IL
KOERTING HANNOVER GMBH, Badenstedter Str. 56, Hannover, Germany 30453 (0511-2129-0; FAX: 0511-2129-223)
 — See our ad on page 69
PICK HEATERS INC., 730 S. Indiana Ave., P.O. Box 516, West Bend, WI 53095 (262-338-1191; FAX: 262-338-8489; www.pickheaters.com)
UNIFLUX / EXOTHERM CORP., 31369 Nichols Sawmill Road, Magnolia, TX 77355 (713-981-9100; FAX: 713-981-7081; info@exotherm.com; www.exotherm.com)
 — See our ad on page 57

Heaters, process slurry

CAST-X Circulation Heaters, Batavia, IL
PICK HEATERS INC., 730 S. Indiana Ave., P.O. Box 516, West Bend, WI 53095 (262-338-1191; FAX: 262-338-8489; www.pickheaters.com)
UNIFLUX / EXOTHERM CORP., 31369 Nichols Sawmill Road, Magnolia, TX 77355 (713-981-9100; FAX: 713-981-7081; info@exotherm.com; www.exotherm.com)
 — See our ad on page 57

Inserts, heat-exchanger tube

CAST-X Circulation Heaters, Batavia, IL

Preheaters

CAST-X Circulation Heaters, Batavia, IL
JLS INTERNATIONAL, INC., 381 Fawn Lane, West Jefferson, NC 28694 (336-877-5571; FAX: 336-877-5579)
UNIFLUX / EXOTHERM CORP., 31369 Nichols Sawmill Road, Magnolia, TX 77355 (713-981-9100; FAX: 713-981-7081; info@exotherm.com; www.exotherm.com)
 — See our ad on page 57
XCHANGER, INC., 1401 S. 7th St., Hopkins, MN 55343 (952-933-2559; www.xchanger.com)

Reboilers

UNIFLUX / EXOTHERM CORP., 31369 Nichols Sawmill Road, Magnolia, TX 77355 (713-981-9100; FAX: 713-981-7081; info@exotherm.com; www.exotherm.com)
 — See our ad on page 57

Superheaters

CAST-X Circulation Heaters, Batavia, IL
JLS INTERNATIONAL, INC., 381 Fawn Lane, West Jefferson, NC 28694 (336-877-5571; FAX: 336-877-5579)
UNIFLUX / EXOTHERM CORP., 31369 Nichols Sawmill Road, Magnolia, TX 77355 (713-981-9100; FAX: 713-981-7081; info@exotherm.com; www.exotherm.com)
 — See our ad on page 57

Troughs, cooled or heated

ANDRITZ SEPARATION, ANDRITZ AG, Stattegger Strasse 18, Graz, Austria 8045 (+43 050 8050; separation@andritz.com; www.andritz.com/separation)

Waste heat recovery units

INDECK POWER EQUIPMENT CO., 1111 Willis Ave. (CE), Wheeling, IL 60090 (847-541-8300; FAX: 847-541-9984; www.indeck.com)
 — See our ad on page 15

HEAT TRANSFER MEDIA

Heat transfer fluids, cooling fluids

EASTMAN, 575 Maryville Centre Drive, Saint Louis, MO 63141 (800-433-6997)
PARATHERM - HEAT TRANSFER FLUIDS, 2009 Renaissance Boulevard, King of Prussia, PA 19406 (610-941-4900; FAX: 610-941-9191)

Heat transfer fluids, heating fluids

EASTMAN, 575 Maryville Centre Drive, Saint Louis, MO 63141 (800-433-6997)
PARATHERM - HEAT TRANSFER FLUIDS, 2009 Renaissance Boulevard, King of Prussia, PA 19406 (610-941-4900; FAX: 610-941-9191)

Heat transfer fluids, other

EASTMAN, 575 Maryville Centre Drive, Saint Louis, MO 63141 (800-433-6997)
PARATHERM - HEAT TRANSFER FLUIDS, 2009 Renaissance Boulevard, King of Prussia, PA 19406 (610-941-4900; FAX: 610-941-9191)

Hot oils

EASTMAN, 575 Maryville Centre Drive, Saint Louis, MO 63141 (800-433-6997)
PARATHERM - HEAT TRANSFER FLUIDS, 2009 Renaissance Boulevard, King of Prussia, PA 19406 (610-941-4900; FAX: 610-941-9191)

Thermal fluids

EASTMAN, 575 Maryville Centre Drive, Saint Louis, MO 63141 (800-433-6997)
PARATHERM - HEAT TRANSFER FLUIDS, 2009 Renaissance Boulevard, King of Prussia, PA 19406 (610-941-4900; FAX: 610-941-9191)

HEATING & COOLING EQUIPMENT, OTHER

Air preheat systems

CAST-X Circulation Heaters, Batavia, IL

Chillers, recirculating

Thermal Care, Niles, IL

Coils

FIN TUBE PRODUCTS, INC., 188 S Lyman St., Suite 100, Wadsworth, OH 44281 (330-334-3736; FAX: 330-334-3848; mb@fintube.com; www.fintube.com)

Generators, steam

INDECK POWER EQUIPMENT CO., 1111 Willis Ave. (CE), Wheeling, IL 60090 (847-541-8300; FAX: 847-541-9984; www.indeck.com)
 — See our ad on page 15

Heaters, air & gas

CAST-X Circulation Heaters, Batavia, IL
UNIFLUX / EXOTHERM CORP., 31369 Nichols Sawmill Road, Magnolia, TX 77355 (713-981-9100; FAX: 713-981-7081; info@exotherm.com; www.exotherm.com)
 — See our ad on page 57
 Water Heating Direct, Fort Worth, TX
XCHANGER, INC., 1401 S. 7th St., Hopkins, MN 55343 (952-933-2559; www.xchanger.com)

Heaters, direct fired

UNIFLUX / EXOTHERM CORP., 31369 Nichols Sawmill Road, Magnolia, TX 77355 (713-981-9100; FAX: 713-981-7081; info@exotherm.com; www.exotherm.com)
 — See our ad on page 57

Heaters, drum

BENKO PRODUCTS, INC., 5350 Evergreen Pkwy., Sheffield Village, OH 44054 (440-934-2180; FAX: 440-934-4052; www.benkoproducts.com)

Heaters, feedwater

UNIFLUX / EXOTHERM CORP., 31369 Nichols Sawmill Road, Magnolia, TX 77355 (713-981-9100; FAX: 713-981-7081; info@exotherm.com; www.exotherm.com)
 — See our ad on page 57

Heaters, finned tube

BENKO PRODUCTS, INC., 5350 Evergreen Pkwy., Sheffield Village, OH 44054 (440-934-2180; FAX: 440-934-4052; www.benkoproducts.com)
FIN TUBE PRODUCTS, INC., 188 S Lyman St., Suite 100, Wadsworth, OH 44281 (330-334-3736; FAX: 330-334-3848; mb@fintube.com; www.fintube.com)
UNIFLUX / EXOTHERM CORP., 31369 Nichols Sawmill Road, Magnolia, TX 77355 (713-981-9100; FAX: 713-981-7081; info@exotherm.com; www.exotherm.com)
 — See our ad on page 57

Heaters, gas fired

UNIFLUX / EXOTHERM CORP., 31369 Nichols Sawmill Road, Magnolia, TX 77355 (713-981-9100; FAX: 713-981-7081; info@exotherm.com; www.exotherm.com)
 — See our ad on page 57

Heaters, helical coil

CAST-X Circulation Heaters, Batavia, IL
FIN TUBE PRODUCTS, INC., 188 S Lyman St., Suite 100, Wadsworth, OH 44281 (330-334-3736; FAX: 330-334-3848; mb@fintube.com; www.fintube.com)
UNIFLUX / EXOTHERM CORP., 31369 Nichols Sawmill Road, Magnolia, TX 77355 (713-981-9100; FAX: 713-981-7081; info@exotherm.com; www.exotherm.com)
 — See our ad on page 57

Heaters, immersion

CAST-X Circulation Heaters, Batavia, IL

Heaters, indirect fired (waterbath)

UNIFLUX / EXOTHERM CORP., 31369 Nichols Sawmill Road, Magnolia, TX 77355 (713-981-9100; FAX: 713-981-7081; info@exotherm.com; www.exotherm.com)
 — See our ad on page 57

Heaters, instantaneous

PICK HEATERS INC., 730 S. Indiana Ave., P.O. Box 516, West Bend, WI 53095 (262-338-1191; FAX: 262-338-8489; www.pickheaters.com)
UNIFLUX / EXOTHERM CORP., 31369 Nichols Sawmill Road, Magnolia, TX 77355 (713-981-9100; FAX: 713-981-7081; info@exotherm.com; www.exotherm.com)
 — See our ad on page 57

Heaters, jacketed

PICK HEATERS INC., 730 S. Indiana Ave., P.O. Box 516, West Bend, WI 53095 (262-338-1191; FAX: 262-338-8489; www.pickheaters.com)

Heaters, molten salt

UNIFLUX / EXOTHERM CORP., 31369 Nichols Sawmill Road, Magnolia, TX 77355 (713-981-9100; FAX: 713-981-7081; info@exotherm.com; www.exotherm.com)
 — See our ad on page 57

Heaters, pipeline

UNIFLUX / EXOTHERM CORP., 31369 Nichols Sawmill Road, Magnolia, TX 77355 (713-981-9100; FAX: 713-981-7081; info@exotherm.com; www.exotherm.com)
 — See our ad on page 57

Heaters, portable

UNIFLUX / EXOTHERM CORP., 31369 Nichols Sawmill Road, Magnolia, TX 77355 (713-981-9100; FAX: 713-981-7081; info@exotherm.com; www.exotherm.com)
 — See our ad on page 57

Heaters, steam injection

GEA GROUP, 9165 Rumsey Road, Columbia, MD 21045 (800-722-6622; www.gea.com)
 — See our ad on page 23
KOERTING HANNOVER GMBH, Badenstedter Str. 56, Hannover, Germany 30453 (0511-2129-0; FAX: 0511-2129-223)
 — See our ad on page 69
PICK HEATERS INC., 730 S. Indiana Ave., P.O. Box 516, West Bend, WI 53095 (262-338-1191; FAX: 262-338-8489; www.pickheaters.com)

Heaters, tank car

PICK HEATERS INC., 730 S. Indiana Ave., P.O. Box 516, West Bend, WI 53095 (262-338-1191; FAX: 262-338-8489; www.pickheaters.com)

Heaters, thermal liquid

Thermal Fluid Systems Inc., Kennesaw, GA
UNIFLUX / EXOTHERM CORP., 31369 Nichols Sawmill Road, Magnolia, TX 77355 (713-981-9100; FAX: 713-981-7081; info@exotherm.com; www.exotherm.com)
 — See our ad on page 57

Heaters, tubular

UNIFLUX / EXOTHERM CORP., 31369 Nichols Sawmill Road, Magnolia, TX 77355 (713-981-9100; FAX: 713-981-7081; info@exotherm.com; www.exotherm.com)
 — See our ad on page 57

Vaporizers

UNIFLUX / EXOTHERM CORP., 31369 Nichols Sawmill Road, Magnolia, TX 77355 (713-981-9100; FAX: 713-981-7081; info@exotherm.com; www.exotherm.com)
 — See our ad on page 57

KILNS, OVENS & FURNACES

Burners, gas

JOHN ZINK HAMWORTHY COMBUSTION, 11920 East Apache Street, Tulsa, OK 74116 (918-234-2800; FAX: 918-234-1800)
UNIFLUX / EXOTHERM CORP., 31369 Nichols Sawmill Road, Magnolia, TX 77355 (713-981-9100; FAX: 713-981-7081; info@exotherm.com; www.exotherm.com)
 —See our ad on page 57

Burners, oil

JOHN ZINK HAMWORTHY COMBUSTION, 11920 East Apache Street, Tulsa, OK 74116 (918-234-2800; FAX: 918-234-1800)

Furnaces, gas burning

UNIFLUX / EXOTHERM CORP., 31369 Nichols Sawmill Road, Magnolia, TX 77355 (713-981-9100; FAX: 713-981-7081; info@exotherm.com; www.exotherm.com)
 —See our ad on page 57

Furnaces, high pressure

UNIFLUX / EXOTHERM CORP., 31369 Nichols Sawmill Road, Magnolia, TX 77355 (713-981-9100; FAX: 713-981-7081; info@exotherm.com; www.exotherm.com)
 —See our ad on page 57

Furnaces, high temperature

UNIFLUX / EXOTHERM CORP., 31369 Nichols Sawmill Road, Magnolia, TX 77355 (713-981-9100; FAX: 713-981-7081; info@exotherm.com; www.exotherm.com)
 —See our ad on page 57

Furnaces, vertical

UNIFLUX / EXOTHERM CORP., 31369 Nichols Sawmill Road, Magnolia, TX 77355 (713-981-9100; FAX: 713-981-7081; info@exotherm.com; www.exotherm.com)
 —See our ad on page 57

Kilns, rotary

METSO MINERALS INDUSTRIES, INC., 2715 Pleasant Valley Road, York, PA 17402 (717-843-8671; FAX: 717-845-5154; www.metso.com)
 —See our ad on page 39

Ovens, drying

PINK GMBH THERMOSYSTEME, Am Kessler 6, 97877 Wertheim, Germany (0049-9342-919-0; FAX: 0049-9342-919-111; www.pink.de)

Ovens, electric

BENKO PRODUCTS, INC., 5350 Evergreen Pkwy., Sheffield Village, OH 44054 (440-934-2180; FAX: 440-934-4052; www.benkoproducts.com)

Ovens, vacuum

PINK GMBH THERMOSYSTEME, Am Kessler 6, 97877 Wertheim, Germany (0049-9342-919-0; FAX: 0049-9342-919-111; www.pink.de)

Roasters, food products

NEUHAUS NEOTECH Maschinen- und Anlagenbau GmbH, Ganderkesee, Germany

MIXING EQUIPMENT FOR FLUIDS

Homogenizers

Admix Inc., Londonderry, NH
EKATO RUEHR- UND MISCHTECHNIK GMBH, Hohe-Flum-Str.37, Schopfheim, Germany D-79650 (+49 7622 290; FAX: +49 7622 29 213; www.ekato.com)
 —See our ad on page 84
FLUID LINE PRODUCTS INC., 38273 Western Pkwy., P.O. Box 1000, Willoughby, OH 44096 (440-946-9470; FAX: 440-946-9472; www.fluidline.com)
JAYGO, INC., 7 Emery Ave., Randolph, NJ 07869 (908-688-3600; FAX: 908-688-6060)
 Myers Mixers, Cudahy, CA
ROSS MIXERS, 710 Old Willets Path, P.O. Box 12308, Hauppauge, NY 11788-0615 (631-234-0500; FAX: 631-234-0691; www.mixers.com)
YSTRAL GMBH, Wettelbrunner Str. 7, Ballrechten-Dottingen, Germany 79282 (+49 7634 5603 900; www.ystral.com)

Homogenizers, high pressure

Admix Inc., Londonderry, NH
EKATO RUEHR- UND MISCHTECHNIK GMBH, Hohe-Flum-Str.37, Schopfheim, Germany D-79650 (+49 7622 290; FAX: +49 7622 29 213; www.ekato.com)
 —See our ad on page 84

FLUID LINE PRODUCTS INC., 38273 Western Pkwy., P.O. Box 1000, Willoughby, OH 44096 (440-946-9470; FAX: 440-946-9472; www.fluidline.com)
ROSS MIXERS, 710 Old Willets Path, P.O. Box 12308, Hauppauge, NY 11788-0615 (631-234-0500; FAX: 631-234-0691; www.mixers.com)

Liquid-mixer parts & accessories

Admix Inc., Londonderry, NH
EKATO RUEHR- UND MISCHTECHNIK GMBH, Hohe-Flum-Str.37, Schopfheim, Germany D-79650 (+49 7622 290; FAX: +49 7622 29 213; www.ekato.com)
 —See our ad on page 84
FLUID LINE PRODUCTS INC., 38273 Western Pkwy., P.O. Box 1000, Willoughby, OH 44096 (440-946-9470; FAX: 440-946-9472; www.fluidline.com)
ROSS MIXERS, 710 Old Willets Path, P.O. Box 12308, Hauppauge, NY 11788-0615 (631-234-0500; FAX: 631-234-0691; www.mixers.com)
 SPX Flow Technology, Ocala, FL

Mixers, air driven

Admix Inc., Londonderry, NH
POPE SCIENTIFIC, INC., P.O. Box 80018, 351 N. Dekora Woods Blvd., Saukville, WI 53080 (262-268-9300; FAX: 262-268-9400; info@popeinc.com; www.popeinc.com)
 SPX Flow Technology, Ocala, FL

Mixers, anchor

EKATO RUEHR- UND MISCHTECHNIK GMBH, Hohe-Flum-Str.37, Schopfheim, Germany D-79650 (+49 7622 290; FAX: +49 7622 29 213; www.ekato.com)
 —See our ad on page 84
FLUID LINE PRODUCTS INC., 38273 Western Pkwy., P.O. Box 1000, Willoughby, OH 44096 (440-946-9470; FAX: 440-946-9472; www.fluidline.com)
 Myers Mixers, Cudahy, CA
ROSS MIXERS, 710 Old Willets Path, P.O. Box 12308, Hauppauge, NY 11788-0615 (631-234-0500; FAX: 631-234-0691; www.mixers.com)
 SPX Flow Technology, Ocala, FL

Mixers, batch

Admix Inc., Londonderry, NH
B&P LITTLEFORD, 1000 Hess Avenue, Saginaw, MI 48601 (989-757-1300; FAX: 989-757-1301; www.bplittleford.com)
EKATO RUEHR- UND MISCHTECHNIK GMBH, Hohe-Flum-Str.37, Schopfheim, Germany D-79650 (+49 7622 290; FAX: +49 7622 29 213; www.ekato.com)
 —See our ad on page 84
FLUID LINE PRODUCTS INC., 38273 Western Pkwy., P.O. Box 1000, Willoughby, OH 44096 (440-946-9470; FAX: 440-946-9472; www.fluidline.com)
 Gebrueder Loedige Maschinenbau GmbH, Paderborn, Germany
JAYGO, INC., 7 Emery Ave., Randolph, NJ 07869 (908-688-3600; FAX: 908-688-6060)
 Myers Mixers, Cudahy, CA
POPE SCIENTIFIC, INC., P.O. Box 80018, 351 N. Dekora Woods Blvd., Saukville, WI 53080 (262-268-9300; FAX: 262-268-9400; info@popeinc.com; www.popeinc.com)
ROSS MIXERS, 710 Old Willets Path, P.O. Box 12308, Hauppauge, NY 11788-0615 (631-234-0500; FAX: 631-234-0691; www.mixers.com)
 SPX Flow Technology, Ocala, FL
YSTRAL GMBH, Wettelbrunner Str. 7, Ballrechten-Dottingen, Germany 79282 (+49 7634 5603 900; www.ystral.com)

Mixers, bottom entering

Admix Inc., Londonderry, NH
EKATO RUEHR- UND MISCHTECHNIK GMBH, Hohe-Flum-Str.37, Schopfheim, Germany D-79650 (+49 7622 290; FAX: +49 7622 29 213; www.ekato.com)
 —See our ad on page 84
FLUID LINE PRODUCTS INC., 38273 Western Pkwy., P.O. Box 1000, Willoughby, OH 44096 (440-946-9470; FAX: 440-946-9472; www.fluidline.com)
 SPX Flow Technology, Ocala, FL

Mixers, chilled

EKATO RUEHR- UND MISCHTECHNIK GMBH, Hohe-Flum-Str.37, Schopfheim, Germany D-79650 (+49 7622 290; FAX: +49 7622 29 213; www.ekato.com)
 —See our ad on page 84
FLUID LINE PRODUCTS INC., 38273 Western Pkwy., P.O. Box 1000, Willoughby, OH 44096 (440-946-9470; FAX: 440-946-9472; www.fluidline.com)
 Myers Mixers, Cudahy, CA
ROSS MIXERS, 710 Old Willets Path, P.O. Box 12308, Hauppauge, NY 11788-0615 (631-234-0500; FAX: 631-234-0691; www.mixers.com)

Mixers, cone

JAYGO, INC., 7 Emery Ave., Randolph, NJ 07869 (908-688-3600; FAX: 908-688-6060)

ROSS MIXERS, 710 Old Willets Path, P.O. Box 12308, Hauppauge, NY 11788-0615 (631-234-0500; FAX: 631-234-0691; www.mixers.com)

Mixers, continuous

Admix Inc., Londonderry, NH
B&P LITTLEFORD, 1000 Hess Avenue, Saginaw, MI 48601 (989-757-1300; FAX: 989-757-1301; www.bplittleford.com)
EKATO RUEHR- UND MISCHTECHNIK GMBH, Hohe-Flum-Str.37, Schopfheim, Germany D-79650 (+49 7622 290; FAX: +49 7622 29 213; www.ekato.com)
 —See our ad on page 84
FLUID LINE PRODUCTS INC., 38273 Western Pkwy., P.O. Box 1000, Willoughby, OH 44096 (440-946-9470; FAX: 440-946-9472; www.fluidline.com)
 Gebrueder Loedige Maschinenbau GmbH, Paderborn, Germany
JAYGO, INC., 7 Emery Ave., Randolph, NJ 07869 (908-688-3600; FAX: 908-688-6060)
JLS INTERNATIONAL, INC., 381 Fawn Lane, West Jefferson, NC 28694 (336-877-5571; FAX: 336-877-5579)
ROSS MIXERS, 710 Old Willets Path, P.O. Box 12308, Hauppauge, NY 11788-0615 (631-234-0500; FAX: 631-234-0691; www.mixers.com)

Mixers, disc

ROSS MIXERS, 710 Old Willets Path, P.O. Box 12308, Hauppauge, NY 11788-0615 (631-234-0500; FAX: 631-234-0691; www.mixers.com)

Mixers, gas-liquid, high intensity

Admix Inc., Londonderry, NH
 Biazzi SA, Chailly/Montreux, Switzerland
EKATO RUEHR- UND MISCHTECHNIK GMBH, Hohe-Flum-Str.37, Schopfheim, Germany D-79650 (+49 7622 290; FAX: +49 7622 29 213; www.ekato.com)
 —See our ad on page 84
FLUID LINE PRODUCTS INC., 38273 Western Pkwy., P.O. Box 1000, Willoughby, OH 44096 (440-946-9470; FAX: 440-946-9472; www.fluidline.com)
KOERTING HANNOVER GMBH, Badenstedter Str. 56, Hannover, Germany 30453 (0511-2129-0; FAX: 0511-2129-223)
 —See our ad on page 69

Mixers, gate

ROSS MIXERS, 710 Old Willets Path, P.O. Box 12308, Hauppauge, NY 11788-0615 (631-234-0500; FAX: 631-234-0691; www.mixers.com)

Mixers, heated

EKATO RUEHR- UND MISCHTECHNIK GMBH, Hohe-Flum-Str.37, Schopfheim, Germany D-79650 (+49 7622 290; FAX: +49 7622 29 213; www.ekato.com)
 —See our ad on page 84
FLUID LINE PRODUCTS INC., 38273 Western Pkwy., P.O. Box 1000, Willoughby, OH 44096 (440-946-9470; FAX: 440-946-9472; www.fluidline.com)
JAYGO, INC., 7 Emery Ave., Randolph, NJ 07869 (908-688-3600; FAX: 908-688-6060)
KOERTING HANNOVER GMBH, Badenstedter Str. 56, Hannover, Germany 30453 (0511-2129-0; FAX: 0511-2129-223)
 —See our ad on page 69
ROSS MIXERS, 710 Old Willets Path, P.O. Box 12308, Hauppauge, NY 11788-0615 (631-234-0500; FAX: 631-234-0691; www.mixers.com)

Mixers, High Viscosity

Admix Inc., Londonderry, NH
HENGFENGTAI PRECISION MACHINERY Co. for MIXING and THICKENING SOLUTIONS since 1991, Wenzhou, Wenzhou, China
 Myers Mixers, Cudahy, CA
ROSS MIXERS, 710 Old Willets Path, P.O. Box 12308, Hauppauge, NY 11788-0615 (631-234-0500; FAX: 631-234-0691; www.mixers.com)

Mixers, jet

EKATO RUEHR- UND MISCHTECHNIK GMBH, Hohe-Flum-Str.37, Schopfheim, Germany D-79650 (+49 7622 290; FAX: +49 7622 29 213; www.ekato.com)
 —See our ad on page 84
FLUID LINE PRODUCTS INC., 38273 Western Pkwy., P.O. Box 1000, Willoughby, OH 44096 (440-946-9470; FAX: 440-946-9472; www.fluidline.com)
GEA GROUP, 9165 Rumsey Road, Columbia, MD 21045 (800-722-6622; www.gea.com)
 —See our ad on page 23
KOERTING HANNOVER GMBH, Badenstedter Str. 56, Hannover, Germany 30453 (0511-2129-0; FAX: 0511-2129-223)
 —See our ad on page 69

Mixers, paddle

DYNAMIC AIR INC., 1125 Willow Lake Blvd., St. Paul, MN 55110-5193 (651-484-2900; FAX: 651-484-7015; www.dynamicair.com)

EKATO RUEHR- UND MISCHTECHNIK GMBH, Hohe-Flum-Str.37, Schopfheim, Germany D-79650 (+49 7622 290; FAX: +49 7622 29 213; www.ekato.com)
—See our ad on page 84

FLUID LINE PRODUCTS INC., 38273 Western Pkwy., P.O. Box 1000, Willoughby, OH 44096 (440-946-9470; FAX: 440-946-9472; www.fluidline.com)

JAYGO, INC., 7 Emery Ave., Randolph, NJ 07869 (908-688-3600; FAX: 908-688-6060)

ROSS MIXERS, 710 Old Willets Path, P.O. Box 12308, Hauppauge, NY 11788-0615 (631-234-0500; FAX: 631-234-0691; www.mixers.com)

Mixers, pipeline (inline)

Admix Inc., Londonderry, NH

JLS INTERNATIONAL, INC., 381 Fawn Lane, West Jefferson, NC 28694 (336-877-5571; FAX: 336-877-5579)

ROSS MIXERS, 710 Old Willets Path, P.O. Box 12308, Hauppauge, NY 11788-0615 (631-234-0500; FAX: 631-234-0691; www.mixers.com)

Mixers, pony

JAYGO, INC., 7 Emery Ave., Randolph, NJ 07869 (908-688-3600; FAX: 908-688-6060)

ROSS MIXERS, 710 Old Willets Path, P.O. Box 12308, Hauppauge, NY 11788-0615 (631-234-0500; FAX: 631-234-0691; www.mixers.com)

Mixers, portable

Admix Inc., Londonderry, NH

ROSS MIXERS, 710 Old Willets Path, P.O. Box 12308, Hauppauge, NY 11788-0615 (631-234-0500; FAX: 631-234-0691; www.mixers.com)

Mixers, pressure

EKATO RUEHR- UND MISCHTECHNIK GMBH, Hohe-Flum-Str.37, Schopfheim, Germany D-79650 (+49 7622 290; FAX: +49 7622 29 213; www.ekato.com)
—See our ad on page 84

FLUID LINE PRODUCTS INC., 38273 Western Pkwy., P.O. Box 1000, Willoughby, OH 44096 (440-946-9470; FAX: 440-946-9472; www.fluidline.com)

Fluitron, Inc., Ivyland, PA

JLS INTERNATIONAL, INC., 381 Fawn Lane, West Jefferson, NC 28694 (336-877-5571; FAX: 336-877-5579)

POPE SCIENTIFIC, INC., P.O. Box 80018, 351 N. Dekora Woods Blvd., Saukville, WI 53080 (262-268-9300; FAX: 262-268-9400; info@popeinc.com; www.popeinc.com)

ROSS MIXERS, 710 Old Willets Path, P.O. Box 12308, Hauppauge, NY 11788-0615 (631-234-0500; FAX: 631-234-0691; www.mixers.com)

Mixers, propeller

Admix Inc., Londonderry, NH

EKATO RUEHR- UND MISCHTECHNIK GMBH, Hohe-Flum-Str.37, Schopfheim, Germany D-79650 (+49 7622 290; FAX: +49 7622 29 213; www.ekato.com)
—See our ad on page 84

FLUID LINE PRODUCTS INC., 38273 Western Pkwy., P.O. Box 1000, Willoughby, OH 44096 (440-946-9470; FAX: 440-946-9472; www.fluidline.com)

POPE SCIENTIFIC, INC., P.O. Box 80018, 351 N. Dekora Woods Blvd., Saukville, WI 53080 (262-268-9300; FAX: 262-268-9400; info@popeinc.com; www.popeinc.com)

ROSS MIXERS, 710 Old Willets Path, P.O. Box 12308, Hauppauge, NY 11788-0615 (631-234-0500; FAX: 631-234-0691; www.mixers.com)

Mixers, side entering

EKATO RUEHR- UND MISCHTECHNIK GMBH, Hohe-Flum-Str.37, Schopfheim, Germany D-79650 (+49 7622 290; FAX: +49 7622 29 213; www.ekato.com)
—See our ad on page 84

FLUID LINE PRODUCTS INC., 38273 Western Pkwy., P.O. Box 1000, Willoughby, OH 44096 (440-946-9470; FAX: 440-946-9472; www.fluidline.com)

Mixers, slurry

Admix Inc., Londonderry, NH

EKATO RUEHR- UND MISCHTECHNIK GMBH, Hohe-Flum-Str.37, Schopfheim, Germany D-79650 (+49 7622 290; FAX: +49 7622 29 213; www.ekato.com)
—See our ad on page 84

FLUID LINE PRODUCTS INC., 38273 Western Pkwy., P.O. Box 1000, Willoughby, OH 44096 (440-946-9470; FAX: 440-946-9472; www.fluidline.com)

HENGFENGTAI PRECISION MACHINERY Co. for MIXING and THICKENING SOLUTIONS since 1991, Wenzhou, Wenzhou, China

JAYGO, INC., 7 Emery Ave., Randolph, NJ 07869 (908-688-3600; FAX: 908-688-6060)

POPE SCIENTIFIC, INC., P.O. Box 80018, 351 N. Dekora Woods Blvd., Saukville, WI 53080 (262-268-9300; FAX: 262-268-9400; info@popeinc.com; www.popeinc.com)

ROSS MIXERS, 710 Old Willets Path, P.O. Box 12308, Hauppauge, NY 11788-0615 (631-234-0500; FAX: 631-234-0691; www.mixers.com)

YSTRAL GMBH, Wettelbrunner Str. 7, Ballrechten-Dottingen, Germany 79282 (+49 7634 5603 900; www.ystral.com)

Mixers, static

Admix Inc., Londonderry, NH

JLS INTERNATIONAL, INC., 381 Fawn Lane, West Jefferson, NC 28694 (336-877-5571; FAX: 336-877-5579)

ROSS MIXERS, 710 Old Willets Path, P.O. Box 12308, Hauppauge, NY 11788-0615 (631-234-0500; FAX: 631-234-0691; www.mixers.com)

SULZER CHEMTECH, Neuwiesenstrasse 15, Winterthur, Switzerland 8401 (4152262372; www.sulzer.com)

Mixers, top entering

Admix Inc., Londonderry, NH

EKATO RUEHR- UND MISCHTECHNIK GMBH, Hohe-Flum-Str.37, Schopfheim, Germany D-79650 (+49 7622 290; FAX: +49 7622 29 213; www.ekato.com)
—See our ad on page 84

FLUID LINE PRODUCTS INC., 38273 Western Pkwy., P.O. Box 1000, Willoughby, OH 44096 (440-946-9470; FAX: 440-946-9472; www.fluidline.com)

POPE SCIENTIFIC, INC., P.O. Box 80018, 351 N. Dekora Woods Blvd., Saukville, WI 53080 (262-268-9300; FAX: 262-268-9400; info@popeinc.com; www.popeinc.com)

ROSS MIXERS, 710 Old Willets Path, P.O. Box 12308, Hauppauge, NY 11788-0615 (631-234-0500; FAX: 631-234-0691; www.mixers.com)

Mixers, turbine

EKATO RUEHR- UND MISCHTECHNIK GMBH, Hohe-Flum-Str.37, Schopfheim, Germany D-79650 (+49 7622 290; FAX: +49 7622 29 213; www.ekato.com)
—See our ad on page 84

FLUID LINE PRODUCTS INC., 38273 Western Pkwy., P.O. Box 1000, Willoughby, OH 44096 (440-946-9470; FAX: 440-946-9472; www.fluidline.com)

ROSS MIXERS, 710 Old Willets Path, P.O. Box 12308, Hauppauge, NY 11788-0615 (631-234-0500; FAX: 631-234-0691; www.mixers.com)

Mixers, vacuum

Admix Inc., Londonderry, NH

EKATO RUEHR- UND MISCHTECHNIK GMBH, Hohe-Flum-Str.37, Schopfheim, Germany D-79650 (+49 7622 290; FAX: +49 7622 29 213; www.ekato.com)
—See our ad on page 84

FLUID LINE PRODUCTS INC., 38273 Western Pkwy., P.O. Box 1000, Willoughby, OH 44096 (440-946-9470; FAX: 440-946-9472; www.fluidline.com)

JAYGO, INC., 7 Emery Ave., Randolph, NJ 07869 (908-688-3600; FAX: 908-688-6060)

Myers Mixers, Cudahy, CA

POPE SCIENTIFIC, INC., P.O. Box 80018, 351 N. Dekora Woods Blvd., Saukville, WI 53080 (262-268-9300; FAX: 262-268-9400; info@popeinc.com; www.popeinc.com)

ROSS MIXERS, 710 Old Willets Path, P.O. Box 12308, Hauppauge, NY 11788-0615 (631-234-0500; FAX: 631-234-0691; www.mixers.com)

YSTRAL GMBH, Wettelbrunner Str. 7, Ballrechten-Dottingen, Germany 79282 (+49 7634 5603 900; www.ystral.com)

Mixers: barrel, drum, carboy

PAUL O. ABBE, 201 Hanson Ct. Suite 125, Wood Dale, IL 60191 (630-350-3012; FAX: 630-238-7584)
—See our ad on page 15

Mixing equipment for gas, air

HENGFENGTAI PRECISION MACHINERY Co. for MIXING and THICKENING SOLUTIONS since 1991, Wenzhou, Wenzhou, China

MIXING EQUIPMENT FOR SOLIDS & FLUIDS

Batching & blending systems

Admix Inc., Londonderry, NH

B&P LITTLEFORD, 1000 Hess Avenue, Saginaw, MI 48601 (989-757-1300; FAX: 989-757-1301; www.bplittleford.com)

EKATO, 48 Spruce Street, Oakland, NJ 07436 (201-825-4684 ext. 205)
—See our ad on page 84

GEMCO, the worldwide mixing and drying authority, Middlesex, NJ

POPE SCIENTIFIC, INC., P.O. Box 80018, 351 N. Dekora Woods Blvd., Saukville, WI 53080 (262-268-9300; FAX: 262-268-9400; info@popeinc.com; www.popeinc.com)

ROSS MIXERS, 710 Old Willets Path, P.O. Box 12308, Hauppauge, NY 11788-0615 (631-234-0500; FAX: 631-234-0691; www.mixers.com)

SIEMENS PROCESS INSTRUMENTATION, 2060 Detwiler Road, Suite 111, Harleysville, PA 19438 (800-365-8766; piabu-request@information.industry@siemens.com; www.usa.siemens.com/pablog)

Blenders, cone

PAUL O. ABBE, 201 Hanson Ct. Suite 125, Wood Dale, IL 60191 (630-350-3012; FAX: 630-238-7584)
—See our ad on page 15

JAYGO, INC., 7 Emery Ave., Randolph, NJ 07869 (908-688-3600; FAX: 908-688-6060)

Munson Machinery Company, Inc., Utica, NY

ROSS MIXERS, 710 Old Willets Path, P.O. Box 12308, Hauppauge, NY 11788-0615 (631-234-0500; FAX: 631-234-0691; www.mixers.com)

Blenders, continuous

PAUL O. ABBE, 201 Hanson Ct. Suite 125, Wood Dale, IL 60191 (630-350-3012; FAX: 630-238-7584)
—See our ad on page 15

Admix Inc., Londonderry, NH

DYNAMIC AIR INC., 1125 Willow Lake Blvd., St. Paul, MN 55110-5193 (651-484-2900; FAX: 651-484-7015; www.dynamicair.com)

EKATO, 48 Spruce Street, Oakland, NJ 07436 (201-825-4684 ext. 205)
—See our ad on page 84

JAYGO, INC., 7 Emery Ave., Randolph, NJ 07869 (908-688-3600; FAX: 908-688-6060)

JENIKE & JOHANSON INC., 400 Business Park Dr., Tyngsboro, MA 01879-1077 (978-649-3300; FAX: 978-649-3399)

ROSS MIXERS, 710 Old Willets Path, P.O. Box 12308, Hauppauge, NY 11788-0615 (631-234-0500; FAX: 631-234-0691; www.mixers.com)

Blenders, horizontal

PAUL O. ABBE, 201 Hanson Ct. Suite 125, Wood Dale, IL 60191 (630-350-3012; FAX: 630-238-7584)
—See our ad on page 15

Admix Inc., Londonderry, NH

EKATO, 48 Spruce Street, Oakland, NJ 07436 (201-825-4684 ext. 205)
—See our ad on page 84

JAYGO, INC., 7 Emery Ave., Randolph, NJ 07869 (908-688-3600; FAX: 908-688-6060)

ROSS MIXERS, 710 Old Willets Path, P.O. Box 12308, Hauppauge, NY 11788-0615 (631-234-0500; FAX: 631-234-0691; www.mixers.com)

Blenders, inline

Admix Inc., Londonderry, NH

JAYGO, INC., 7 Emery Ave., Randolph, NJ 07869 (908-688-3600; FAX: 908-688-6060)

ROSS MIXERS, 710 Old Willets Path, P.O. Box 12308, Hauppauge, NY 11788-0615 (631-234-0500; FAX: 631-234-0691; www.mixers.com)

Blenders, liquid feed

PAUL O. ABBE, 201 Hanson Ct. Suite 125, Wood Dale, IL 60191 (630-350-3012; FAX: 630-238-7584)
—See our ad on page 15

Admix Inc., Londonderry, NH

EKATO RUEHR- UND MISCHTECHNIK GMBH, Hohe-Flum-Str.37, Schopfheim, Germany D-79650 (+49 7622 290; FAX: +49 7622 29 213; www.ekato.com)
—See our ad on page 84

FLUID LINE PRODUCTS INC., 38273 Western Pkwy., P.O. Box 1000, Willoughby, OH 44096 (440-946-9470; FAX: 440-946-9472; www.fluidline.com)

ROSS MIXERS, 710 Old Willets Path, P.O. Box 12308, Hauppauge, NY 11788-0615 (631-234-0500; FAX: 631-234-0691; www.mixers.com)

Blenders, pneumatic

DYNAMIC AIR INC., 1125 Willow Lake Blvd., St. Paul, MN 55110-5193 (651-484-2900; FAX: 651-484-7015; www.dynamicair.com)

Blenders, ribbon

PAUL O. ABBE, 201 Hanson Ct. Suite 125, Wood Dale, IL 60191 (630-350-3012; FAX: 630-238-7584)
—See our ad on page 15

EKATO, 48 Spruce Street, Oakland, NJ 07436 (201-825-4684 ext. 205)
—See our ad on page 84

EKATO RUEHR- UND MISCHTECHNIK GMBH, Hohe-Flum-Str.37, Schopfheim, Germany D-79650 (+49 7622 290; FAX: +49 7622 29 213; www.ekato.com)
—See our ad on page 84

FLUID LINE PRODUCTS INC., 38273 Western Pkwy., P.O. Box 1000, Willoughby, OH 44096 (440-946-9470; FAX: 440-946-9472; www.fluidline.com)

JAYGO, INC., 7 Emery Ave., Randolph, NJ 07869 (908-688-3600; FAX: 908-688-6060)

Munson Machinery Company, Inc., Utica, NY

ROSS MIXERS, 710 Old Willets Path, P.O. Box 12308, Hauppauge, NY 11788-0615 (631-234-0500; FAX: 631-234-0691; www.mixers.com)

Blenders, spiral

PAUL O. ABBE, 201 Hanson Ct. Suite 125, Wood Dale, IL 60191 (630-350-3012; FAX: 630-238-7584)
—See our ad on page 15

EKATO, 48 Spruce Street, Oakland, NJ 07436 (201-825-4684 ext. 205)
—See our ad on page 84

EKATO RUEHR- UND MISCHTECHNIK GMBH, Hoheflum-Str.37, Schopfheim, Germany D-79650 (+49 7622 290; FAX: +49 7622 29 213; www.ekato.com)
—See our ad on page 84

FLUID LINE PRODUCTS INC., 38273 Western Pkwy., P.O. Box 1000, Willoughby, OH 44096 (440-946-9470; FAX: 440-946-9472; www.fluidline.com)

JAYGO, INC., 7 Emery Ave., Randolph, NJ 07869 (908-688-3600; FAX: 908-688-6060)

ROSS MIXERS, 710 Old Willets Path, P.O. Box 12308, Hauppauge, NY 11788-0615 (631-234-0500; FAX: 631-234-0691; www.mixers.com)

Blenders, tumbling V

PAUL O. ABBE, 201 Hanson Ct. Suite 125, Wood Dale, IL 60191 (630-350-3012; FAX: 630-238-7584)
—See our ad on page 15

JAYGO, INC., 7 Emery Ave., Randolph, NJ 07869 (908-688-3600; FAX: 908-688-6060)

JENIKE & JOHANSON INC., 400 Business Park Dr., Tyngsboro, MA 01879-1077 (978-649-3300; FAX: 978-649-3399)

Munson Machinery Company, Inc., Utica, NY

ROSS MIXERS, 710 Old Willets Path, P.O. Box 12308, Hauppauge, NY 11788-0615 (631-234-0500; FAX: 631-234-0691; www.mixers.com)

Mixers, continuous kneaders

JAYGO, INC., 7 Emery Ave., Randolph, NJ 07869 (908-688-3600; FAX: 908-688-6060)

ROSS MIXERS, 710 Old Willets Path, P.O. Box 12308, Hauppauge, NY 11788-0615 (631-234-0500; FAX: 631-234-0691; www.mixers.com)

Mixers, double arm kneaders

PAUL O. ABBE, 201 Hanson Ct. Suite 125, Wood Dale, IL 60191 (630-350-3012; FAX: 630-238-7584)
—See our ad on page 15

JAYGO, INC., 7 Emery Ave., Randolph, NJ 07869 (908-688-3600; FAX: 908-688-6060)

ROSS MIXERS, 710 Old Willets Path, P.O. Box 12308, Hauppauge, NY 11788-0615 (631-234-0500; FAX: 631-234-0691; www.mixers.com)

Mixers, gravity flow

JENIKE & JOHANSON INC., 400 Business Park Dr., Tyngsboro, MA 01879-1077 (978-649-3300; FAX: 978-649-3399)

ROSS MIXERS, 710 Old Willets Path, P.O. Box 12308, Hauppauge, NY 11788-0615 (631-234-0500; FAX: 631-234-0691; www.mixers.com)

Mixers, high shear

PAUL O. ABBE, 201 Hanson Ct. Suite 125, Wood Dale, IL 60191 (630-350-3012; FAX: 630-238-7584)
—See our ad on page 15

Admix Inc., Londonderry, NH

EKATO, 48 Spruce Street, Oakland, NJ 07436 (201-825-4684 ext. 205)
—See our ad on page 84

EKATO RUEHR- UND MISCHTECHNIK GMBH, Hoheflum-Str.37, Schopfheim, Germany D-79650 (+49 7622 290; FAX: +49 7622 29 213; www.ekato.com)
—See our ad on page 84

FLUID LINE PRODUCTS INC., 38273 Western Pkwy., P.O. Box 1000, Willoughby, OH 44096 (440-946-9470; FAX: 440-946-9472; www.fluidline.com)

JAYGO, INC., 7 Emery Ave., Randolph, NJ 07869 (908-688-3600; FAX: 908-688-6060)

JLS INTERNATIONAL, INC., 381 Fawn Lane, West Jefferson, NC 28694 (336-877-5571; FAX: 336-877-5579)

Myers Mixers, Cudahy, CA

ROSS MIXERS, 710 Old Willets Path, P.O. Box 12308, Hauppauge, NY 11788-0615 (631-234-0500; FAX: 631-234-0691; www.mixers.com)

YSTRAL GMBH, Wettenbrunner Str. 7, Ballrechten-Dottingen, Germany 79282 (+49 7634 5603 900; www.ystral.com)

Mixers, magnetically coupled

EKATO, 48 Spruce Street, Oakland, NJ 07436 (201-825-4684 ext. 205)
—See our ad on page 84

EKATO RUEHR- UND MISCHTECHNIK GMBH, Hoheflum-Str.37, Schopfheim, Germany D-79650 (+49 7622 290; FAX: +49 7622 29 213; www.ekato.com)
—See our ad on page 84

FLUID LINE PRODUCTS INC., 38273 Western Pkwy., P.O. Box 1000, Willoughby, OH 44096 (440-946-9470; FAX: 440-946-9472; www.fluidline.com)

Mixers, motionless

Admix Inc., Londonderry, NH

JLS INTERNATIONAL, INC., 381 Fawn Lane, West Jefferson, NC 28694 (336-877-5571; FAX: 336-877-5579)

ROSS MIXERS, 710 Old Willets Path, P.O. Box 12308, Hauppauge, NY 11788-0615 (631-234-0500; FAX: 631-234-0691; www.mixers.com)

Mixers, other solid-liquid

PAUL O. ABBE, 201 Hanson Ct. Suite 125, Wood Dale, IL 60191 (630-350-3012; FAX: 630-238-7584)
—See our ad on page 15

Admix Inc., Londonderry, NH

DYNAMIC AIR INC., 1125 Willow Lake Blvd., St. Paul, MN 55110-5193 (651-484-2900; FAX: 651-484-7015; www.dynamicair.com)

EKATO, 48 Spruce Street, Oakland, NJ 07436 (201-825-4684 ext. 205)
—See our ad on page 84

EKATO RUEHR- UND MISCHTECHNIK GMBH, Hoheflum-Str.37, Schopfheim, Germany D-79650 (+49 7622 290; FAX: +49 7622 29 213; www.ekato.com)
—See our ad on page 84

FLUID LINE PRODUCTS INC., 38273 Western Pkwy., P.O. Box 1000, Willoughby, OH 44096 (440-946-9470; FAX: 440-946-9472; www.fluidline.com)

GEA GROUP, 9165 Rumsey Road, Columbia, MD 21045 (800-722-6622; www.gea.com)
—See our ad on page 23

GEMCO, the worldwide mixing and drying authority, Middlesex, NJ

Myers Mixers, Cudahy, CA

ROSS MIXERS, 710 Old Willets Path, P.O. Box 12308, Hauppauge, NY 11788-0615 (631-234-0500; FAX: 631-234-0691; www.mixers.com)

Mixers, pan

ROSS MIXERS, 710 Old Willets Path, P.O. Box 12308, Hauppauge, NY 11788-0615 (631-234-0500; FAX: 631-234-0691; www.mixers.com)

Mixers, planetary

PAUL O. ABBE, 201 Hanson Ct. Suite 125, Wood Dale, IL 60191 (630-350-3012; FAX: 630-238-7584)
—See our ad on page 15

EKATO, 48 Spruce Street, Oakland, NJ 07436 (201-825-4684 ext. 205)
—See our ad on page 84

EKATO RUEHR- UND MISCHTECHNIK GMBH, Hoheflum-Str.37, Schopfheim, Germany D-79650 (+49 7622 290; FAX: +49 7622 29 213; www.ekato.com)
—See our ad on page 84

FLUID LINE PRODUCTS INC., 38273 Western Pkwy., P.O. Box 1000, Willoughby, OH 44096 (440-946-9470; FAX: 440-946-9472; www.fluidline.com)

JAYGO, INC., 7 Emery Ave., Randolph, NJ 07869 (908-688-3600; FAX: 908-688-6060)

ROSS MIXERS, 710 Old Willets Path, P.O. Box 12308, Hauppauge, NY 11788-0615 (631-234-0500; FAX: 631-234-0691; www.mixers.com)

Mixers, ribbon

PAUL O. ABBE, 201 Hanson Ct. Suite 125, Wood Dale, IL 60191 (630-350-3012; FAX: 630-238-7584)
—See our ad on page 15

EKATO RUEHR- UND MISCHTECHNIK GMBH, Hoheflum-Str.37, Schopfheim, Germany D-79650 (+49 7622 290; FAX: +49 7622 29 213; www.ekato.com)
—See our ad on page 84

FLUID LINE PRODUCTS INC., 38273 Western Pkwy., P.O. Box 1000, Willoughby, OH 44096 (440-946-9470; FAX: 440-946-9472; www.fluidline.com)

JAYGO, INC., 7 Emery Ave., Randolph, NJ 07869 (908-688-3600; FAX: 908-688-6060)

ROSS MIXERS, 710 Old Willets Path, P.O. Box 12308, Hauppauge, NY 11788-0615 (631-234-0500; FAX: 631-234-0691; www.mixers.com)

Mixers, roller

ROSS MIXERS, 710 Old Willets Path, P.O. Box 12308, Hauppauge, NY 11788-0615 (631-234-0500; FAX: 631-234-0691; www.mixers.com)

Mixers, rotary blade

PAUL O. ABBE, 201 Hanson Ct. Suite 125, Wood Dale, IL 60191 (630-350-3012; FAX: 630-238-7584)
—See our ad on page 15

EKATO, 48 Spruce Street, Oakland, NJ 07436 (201-825-4684 ext. 205)
—See our ad on page 84

JAYGO, INC., 7 Emery Ave., Randolph, NJ 07869 (908-688-3600; FAX: 908-688-6060)

ROSS MIXERS, 710 Old Willets Path, P.O. Box 12308, Hauppauge, NY 11788-0615 (631-234-0500; FAX: 631-234-0691; www.mixers.com)

Mixers, rotary disc

EKATO, 48 Spruce Street, Oakland, NJ 07436 (201-825-4684 ext. 205)
—See our ad on page 84

EKATO RUEHR- UND MISCHTECHNIK GMBH, Hoheflum-Str.37, Schopfheim, Germany D-79650 (+49 7622 290; FAX: +49 7622 29 213; www.ekato.com)
—See our ad on page 84

FLUID LINE PRODUCTS INC., 38273 Western Pkwy., P.O. Box 1000, Willoughby, OH 44096 (440-946-9470; FAX: 440-946-9472; www.fluidline.com)

Mixers, rotary drum

PAUL O. ABBE, 201 Hanson Ct. Suite 125, Wood Dale, IL 60191 (630-350-3012; FAX: 630-238-7584)
—See our ad on page 15

Munson Machinery Company, Inc., Utica, NY

Mixers, screw

PAUL O. ABBE, 201 Hanson Ct. Suite 125, Wood Dale, IL 60191 (630-350-3012; FAX: 630-238-7584)
—See our ad on page 15

EKATO RUEHR- UND MISCHTECHNIK GMBH, Hoheflum-Str.37, Schopfheim, Germany D-79650 (+49 7622 290; FAX: +49 7622 29 213; www.ekato.com)
—See our ad on page 84

FLUID LINE PRODUCTS INC., 38273 Western Pkwy., P.O. Box 1000, Willoughby, OH 44096 (440-946-9470; FAX: 440-946-9472; www.fluidline.com)

JAYGO, INC., 7 Emery Ave., Randolph, NJ 07869 (908-688-3600; FAX: 908-688-6060)

ROSS MIXERS, 710 Old Willets Path, P.O. Box 12308, Hauppauge, NY 11788-0615 (631-234-0500; FAX: 631-234-0691; www.mixers.com)

Mixers, sealless

EKATO, 48 Spruce Street, Oakland, NJ 07436 (201-825-4684 ext. 205)
—See our ad on page 84

Mixers, spiral ribbon

PAUL O. ABBE, 201 Hanson Ct. Suite 125, Wood Dale, IL 60191 (630-350-3012; FAX: 630-238-7584)
—See our ad on page 15

EKATO RUEHR- UND MISCHTECHNIK GMBH, Hoheflum-Str.37, Schopfheim, Germany D-79650 (+49 7622 290; FAX: +49 7622 29 213; www.ekato.com)
—See our ad on page 84

FLUID LINE PRODUCTS INC., 38273 Western Pkwy., P.O. Box 1000, Willoughby, OH 44096 (440-946-9470; FAX: 440-946-9472; www.fluidline.com)

JAYGO, INC., 7 Emery Ave., Randolph, NJ 07869 (908-688-3600; FAX: 908-688-6060)

ROSS MIXERS, 710 Old Willets Path, P.O. Box 12308, Hauppauge, NY 11788-0615 (631-234-0500; FAX: 631-234-0691; www.mixers.com)

Mixers, spiral screw

PAUL O. ABBE, 201 Hanson Ct. Suite 125, Wood Dale, IL 60191 (630-350-3012; FAX: 630-238-7584)
—See our ad on page 15

EKATO RUEHR- UND MISCHTECHNIK GMBH, Hoheflum-Str.37, Schopfheim, Germany D-79650 (+49 7622 290; FAX: +49 7622 29 213; www.ekato.com)
—See our ad on page 84

FLUID LINE PRODUCTS INC., 38273 Western Pkwy., P.O. Box 1000, Willoughby, OH 44096 (440-946-9470; FAX: 440-946-9472; www.fluidline.com)

Mixers, vacuum tumble

PAUL O. ABBE, 201 Hanson Ct. Suite 125, Wood Dale, IL 60191 (630-350-3012; FAX: 630-238-7584)
—See our ad on page 15

JAYGO, INC., 7 Emery Ave., Randolph, NJ 07869 (908-688-3600; FAX: 908-688-6060)

ROSS MIXERS, 710 Old Willets Path, P.O. Box 12308, Hauppauge, NY 11788-0615 (631-234-0500; FAX: 631-234-0691; www.mixers.com)

Mixers, vertical stationary

JAYGO, INC., 7 Emery Ave., Randolph, NJ 07869 (908-688-3600; FAX: 908-688-6060)

ROSS MIXERS, 710 Old Willets Path, P.O. Box 12308, Hauppauge, NY 11788-0615 (631-234-0500; FAX: 631-234-0691; www.mixers.com)

Mullers

PAUL O. ABBE, 201 Hanson Ct. Suite 125, Wood Dale, IL 60191 (630-350-3012; FAX: 630-238-7584)
—See our ad on page 15

Solid-liquid-mixer parts & accessories

PAUL O. ABBE, 201 Hanson Ct. Suite 125, Wood Dale, IL 60191 (630-350-3012; FAX: 630-238-7584)
—See our ad on page 15

Admix Inc., Londonderry, NH

EKATO, 48 Spruce Street, Oakland, NJ 07436 (201-825-4684 ext. 205)

—See our ad on page 84

EKATO RUEHR- UND MISCHTECHNIK GMBH, Hohe-Flum-Str.37, Schopfheim, Germany D-79650 (+49 7622 290; FAX: + 49 7622 29 213; www.ekato.com)

—See our ad on page 84

FLUID LINE PRODUCTS INC., 38273 Western Pkwy., P.O. Box 1000, Willoughby, OH 44096 (440-946-9470; FAX: 440-946-9472; www.fluidline.com)

PACKINGS, TRAYS FOR TOWERS & COLUMNS

Packings, tower & column, ceramic

KOCH-GLITSCH, INC., 4111 E. 37th St. N., Wichita, KS 67220 (316-828-5110; FAX: 316-828-7985)

—See our ad inside front cover

Packings, tower & column, metal

KOCH-GLITSCH, INC., 4111 E. 37th St. N., Wichita, KS 67220 (316-828-5110; FAX: 316-828-7985)

—See our ad inside front cover

Packings, tower & column, plastic

KOCH-GLITSCH, INC., 4111 E. 37th St. N., Wichita, KS 67220 (316-828-5110; FAX: 316-828-7985)

—See our ad inside front cover

Packings, tower & column, random

KOCH-GLITSCH, INC., 4111 E. 37th St. N., Wichita, KS 67220 (316-828-5110; FAX: 316-828-7985)

—See our ad inside front cover

Packings, tower & column, structured

KOCH-GLITSCH, INC., 4111 E. 37th St. N., Wichita, KS 67220 (316-828-5110; FAX: 316-828-7985)

—See our ad inside front cover

Packings, trays for towers & columns

KOCH-GLITSCH, INC., 4111 E. 37th St. N., Wichita, KS 67220 (316-828-5110; FAX: 316-828-7985)

—See our ad inside front cover

Saddles, polyethylene, tower packings

KOCH-GLITSCH, INC., 4111 E. 37th St. N., Wichita, KS 67220 (316-828-5110; FAX: 316-828-7985)

—See our ad inside front cover

Trays & tower internals

KOCH-GLITSCH, INC., 4111 E. 37th St. N., Wichita, KS 67220 (316-828-5110; FAX: 316-828-7985)

—See our ad inside front cover

SULZER CHEMTECH, Neuwiesenstrasse 15, Winterthur, Switzerland 8401 (41522623722; www.sulzer.com)

PROCESS VESSELS & REACTORS

Autoclaves

Biazz SA, Chailly/Montreux, Switzerland

EKATO RUEHR- UND MISCHTECHNIK GMBH, Hohe-Flum-Str.37, Schopfheim, Germany D-79650 (+49 7622 290; FAX: + 49 7622 29 213; www.ekato.com)

—See our ad on page 84

FLUID LINE PRODUCTS INC., 38273 Western Pkwy., P.O. Box 1000, Willoughby, OH 44096 (440-946-9470; FAX: 440-946-9472; www.fluidline.com)

Fluitron, Inc., Ivyland, PA

Bioreactors

EKATO RUEHR- UND MISCHTECHNIK GMBH, Hohe-Flum-Str.37, Schopfheim, Germany D-79650 (+49 7622 290; FAX: + 49 7622 29 213; www.ekato.com)

—See our ad on page 84

FLUID LINE PRODUCTS INC., 38273 Western Pkwy., P.O. Box 1000, Willoughby, OH 44096 (440-946-9470; FAX: 440-946-9472; www.fluidline.com)

POPE SCIENTIFIC, INC., P.O. Box 80018, 351 N. Dekora Woods Blvd., Saukville, WI 53080 (262-268-9300; FAX: 262-268-9400; info@popeinc.com; www.popeinc.com)

Coalescers

Filtration Technology Corporation, Houston, TX

KOCH-GLITSCH, INC., 4111 E. 37th St. N., Wichita, KS 67220 (316-828-5110; FAX: 316-828-7985)

—See our ad inside front cover

Deaerators, degasifiers

CROLL REYNOLDS CO. INC., Six Campus Drive, Parsippany, NJ 07054 (908-232-4200; FAX: 908-232-2146; info@croll.com; www.croll.com)

JAYGO, INC., 7 Emery Ave., Randolph, NJ 07869 (908-688-3600; FAX: 908-688-6060)

KOCH-GLITSCH, INC., 4111 E. 37th St. N., Wichita, KS 67220 (316-828-5110; FAX: 316-828-7985)

—See our ad inside front cover

POPE SCIENTIFIC, INC., P.O. Box 80018, 351 N. Dekora Woods Blvd., Saukville, WI 53080 (262-268-9300; FAX: 262-268-9400; info@popeinc.com; www.popeinc.com)

ROSS MIXERS, 710 Old Willets Path, P.O. Box 12308, Hauppauge, NY 11788-0615 (631-234-0500; FAX: 631-234-0691; www.mixers.com)

Digesters, cookers

ROSS MIXERS, 710 Old Willets Path, P.O. Box 12308, Hauppauge, NY 11788-0615 (631-234-0500; FAX: 631-234-0691; www.mixers.com)

Digesters, cookers

ROSS MIXERS, 710 Old Willets Path, P.O. Box 12308, Hauppauge, NY 11788-0615 (631-234-0500; FAX: 631-234-0691; www.mixers.com)

Fermentation equipment & fermentors

EKATO RUEHR- UND MISCHTECHNIK GMBH, Hohe-Flum-Str.37, Schopfheim, Germany D-79650 (+49 7622 290; FAX: + 49 7622 29 213; www.ekato.com)

—See our ad on page 84

FLUID LINE PRODUCTS INC., 38273 Western Pkwy., P.O. Box 1000, Willoughby, OH 44096 (440-946-9470; FAX: 440-946-9472; www.fluidline.com)

POPE SCIENTIFIC, INC., P.O. Box 80018, 351 N. Dekora Woods Blvd., Saukville, WI 53080 (262-268-9300; FAX: 262-268-9400; info@popeinc.com; www.popeinc.com)

Generators, carbon dioxide

CAST-X Circulation Heaters, Batavia, IL

Generators, hydrogen

CAST-X Circulation Heaters, Batavia, IL

Generators, nitrogen

CAST-X Circulation Heaters, Batavia, IL

Generators, nitrogen

CAST-X Circulation Heaters, Batavia, IL

Hydrogenation reactors

CAST-X Circulation Heaters, Batavia, IL

EKATO RUEHR- UND MISCHTECHNIK GMBH, Hohe-Flum-Str.37, Schopfheim, Germany D-79650 (+49 7622 290; FAX: + 49 7622 29 213; www.ekato.com)

—See our ad on page 84

FLUID LINE PRODUCTS INC., 38273 Western Pkwy., P.O. Box 1000, Willoughby, OH 44096 (440-946-9470; FAX: 440-946-9472; www.fluidline.com)

PARR INSTRUMENT COMPANY, 211 53rd Street, Moline, IL 61265 (309-762-7716; FAX: 309-762-9453; lisa.randolph@parrinst.com; www.parrinst.com)

Kettles, agitated

EKATO RUEHR- UND MISCHTECHNIK GMBH, Hohe-Flum-Str.37, Schopfheim, Germany D-79650 (+49 7622 290; FAX: + 49 7622 29 213; www.ekato.com)

—See our ad on page 84

FLUID LINE PRODUCTS INC., 38273 Western Pkwy., P.O. Box 1000, Willoughby, OH 44096 (440-946-9470; FAX: 440-946-9472; www.fluidline.com)

Fluitron, Inc., Ivyland, PA

ROSS MIXERS, 710 Old Willets Path, P.O. Box 12308, Hauppauge, NY 11788-0615 (631-234-0500; FAX: 631-234-0691; www.mixers.com)

Kettles, crystallizing

POPE SCIENTIFIC, INC., P.O. Box 80018, 351 N. Dekora Woods Blvd., Saukville, WI 53080 (262-268-9300; FAX: 262-268-9400; info@popeinc.com; www.popeinc.com)

ROSS MIXERS, 710 Old Willets Path, P.O. Box 12308, Hauppauge, NY 11788-0615 (631-234-0500; FAX: 631-234-0691; www.mixers.com)

Kettles, electrically heated

POPE SCIENTIFIC, INC., P.O. Box 80018, 351 N. Dekora Woods Blvd., Saukville, WI 53080 (262-268-9300; FAX: 262-268-9400; info@popeinc.com; www.popeinc.com)

ROSS MIXERS, 710 Old Willets Path, P.O. Box 12308, Hauppauge, NY 11788-0615 (631-234-0500; FAX: 631-234-0691; www.mixers.com)

Kettles, electrically heated

POPE SCIENTIFIC, INC., P.O. Box 80018, 351 N. Dekora Woods Blvd., Saukville, WI 53080 (262-268-9300; FAX: 262-268-9400; info@popeinc.com; www.popeinc.com)

ROSS MIXERS, 710 Old Willets Path, P.O. Box 12308, Hauppauge, NY 11788-0615 (631-234-0500; FAX: 631-234-0691; www.mixers.com)

ROSS MIXERS, 710 Old Willets Path, P.O. Box 12308, Hauppauge, NY 11788-0615 (631-234-0500; FAX: 631-234-0691; www.mixers.com)

ROSS MIXERS, 710 Old Willets Path, P.O. Box 12308, Hauppauge, NY 11788-0615 (631-234-0500; FAX: 631-234-0691; www.mixers.com)

Kettles, jacketed

Admix Inc., Londonderry, NH

EKATO RUEHR- UND MISCHTECHNIK GMBH, Hohe-Flum-Str.37, Schopfheim, Germany D-79650 (+49 7622 290; FAX: + 49 7622 29 213; www.ekato.com)

—See our ad on page 84

FLUID LINE PRODUCTS INC., 38273 Western Pkwy., P.O. Box 1000, Willoughby, OH 44096 (440-946-9470; FAX: 440-946-9472; www.fluidline.com)

JAYGO, INC., 7 Emery Ave., Randolph, NJ 07869 (908-688-3600; FAX: 908-688-6060)

ROSS MIXERS, 710 Old Willets Path, P.O. Box 12308, Hauppauge, NY 11788-0615 (631-234-0500; FAX: 631-234-0691; www.mixers.com)

Kettles, melting

ROSS MIXERS, 710 Old Willets Path, P.O. Box 12308, Hauppauge, NY 11788-0615 (631-234-0500; FAX: 631-234-0691; www.mixers.com)

Kettles, special metals

EKATO RUEHR- UND MISCHTECHNIK GMBH, Hohe-Flum-Str.37, Schopfheim, Germany D-79650 (+49 7622 290; FAX: + 49 7622 29 213; www.ekato.com)

—See our ad on page 84

FLUID LINE PRODUCTS INC., 38273 Western Pkwy., P.O. Box 1000, Willoughby, OH 44096 (440-946-9470; FAX: 440-946-9472; www.fluidline.com)

ROSS MIXERS, 710 Old Willets Path, P.O. Box 12308, Hauppauge, NY 11788-0615 (631-234-0500; FAX: 631-234-0691; www.mixers.com)

Kettles, vacuum

Admix Inc., Londonderry, NH

EKATO RUEHR- UND MISCHTECHNIK GMBH, Hohe-Flum-Str.37, Schopfheim, Germany D-79650 (+49 7622 290; FAX: + 49 7622 29 213; www.ekato.com)

—See our ad on page 84

FLUID LINE PRODUCTS INC., 38273 Western Pkwy., P.O. Box 1000, Willoughby, OH 44096 (440-946-9470; FAX: 440-946-9472; www.fluidline.com)

JAYGO, INC., 7 Emery Ave., Randolph, NJ 07869 (908-688-3600; FAX: 908-688-6060)

POPE SCIENTIFIC, INC., P.O. Box 80018, 351 N. Dekora Woods Blvd., Saukville, WI 53080 (262-268-9300; FAX: 262-268-9400; info@popeinc.com; www.popeinc.com)

ROSS MIXERS, 710 Old Willets Path, P.O. Box 12308, Hauppauge, NY 11788-0615 (631-234-0500; FAX: 631-234-0691; www.mixers.com)

ROSS MIXERS, 710 Old Willets Path, P.O. Box 12308, Hauppauge, NY 11788-0615 (631-234-0500; FAX: 631-234-0691; www.mixers.com)

ROSS MIXERS, 710 Old Willets Path, P.O. Box 12308, Hauppauge, NY 11788-0615 (631-234-0500; FAX: 631-234-0691; www.mixers.com)

ROSS MIXERS, 710 Old Willets Path, P.O. Box 12308, Hauppauge, NY 11788-0615 (631-234-0500; FAX: 631-234-0691; www.mixers.com)

ROSS MIXERS, 710 Old Willets Path, P.O. Box 12308, Hauppauge, NY 11788-0615 (631-234-0500; FAX: 631-234-0691; www.mixers.com)

ROSS MIXERS, 710 Old Willets Path, P.O. Box 12308, Hauppauge, NY 11788-0615 (631-234-0500; FAX: 631-234-0691; www.mixers.com)

ROSS MIXERS, 710 Old Willets Path, P.O. Box 12308, Hauppauge, NY 11788-0615 (631-234-0500; FAX: 631-234-0691; www.mixers.com)

ROSS MIXERS, 710 Old Willets Path, P.O. Box 12308, Hauppauge, NY 11788-0615 (631-234-0500; FAX: 631-234-0691; www.mixers.com)

ROSS MIXERS, 710 Old Willets Path, P.O. Box 12308, Hauppauge, NY 11788-0615 (631-234-0500; FAX: 631-234-0691; www.mixers.com)

ROSS MIXERS, 710 Old Willets Path, P.O. Box 12308, Hauppauge, NY 11788-0615 (631-234-0500; FAX: 631-234-0691; www.mixers.com)

ROSS MIXERS, 710 Old Willets Path, P.O. Box 12308, Hauppauge, NY 11788-0615 (631-234-0500; FAX: 631-234-0691; www.mixers.com)

ROSS MIXERS, 710 Old Willets Path, P.O. Box 12308, Hauppauge, NY 11788-0615 (631-234-0500; FAX: 631-234-0691; www.mixers.com)

ROSS MIXERS, 710 Old Willets Path, P.O. Box 12308, Hauppauge, NY 11788-0615 (631-234-0500; FAX: 631-234-0691; www.mixers.com)

ROSS MIXERS, 710 Old Willets Path, P.O. Box 12308, Hauppauge, NY 11788-0615 (631-234-0500; FAX: 631-234-0691; www.mixers.com)

ROSS MIXERS, 710 Old Willets Path, P.O. Box 12308, Hauppauge, NY 11788-0615 (631-234-0500; FAX: 631-234-0691; www.mixers.com)

ROSS MIXERS, 710 Old Willets Path, P.O. Box 12308, Hauppauge, NY 11788-0615 (631-234-0500; FAX: 631-234-0691; www.mixers.com)

ROSS MIXERS, 710 Old Willets Path, P.O. Box 12308, Hauppauge, NY 11788-0615 (631-234-0500; FAX: 631-234-0691; www.mixers.com)

ROSS MIXERS, 710 Old Willets Path, P.O. Box 12308, Hauppauge, NY 11788-0615 (631-234-0500; FAX: 631-234-0691; www.mixers.com)

ROSS MIXERS, 710 Old Willets Path, P.O. Box 12308, Hauppauge, NY 11788-0615 (631-234-0500; FAX: 631-234-0691; www.mixers.com)

ROSS MIXERS, 710 Old Willets Path, P.O. Box 12308, Hauppauge, NY 11788-0615 (631-234-0500; FAX: 631-234-0691; www.mixers.com)

ROSS MIXERS, 710 Old Willets Path, P.O. Box 12308, Hauppauge, NY 11788-0615 (631-234-0500; FAX: 631-234-0691; www.mixers.com)

ROSS MIXERS, 710 Old Willets Path, P.O. Box 12308, Hauppauge, NY 11788-0615 (631-234-0500; FAX: 631-234-0691; www.mixers.com)

ROSS MIXERS, 710 Old Willets Path, P.O. Box 12308, Hauppauge, NY 11788-0615 (631-234-0500; FAX: 631-234-0691; www.mixers.com)

ROSS MIXERS, 710 Old Willets Path, P.O. Box 12308, Hauppauge, NY 11788-0615 (631-234-0500; FAX: 631-234-0691; www.mixers.com)

ROSS MIXERS, 710 Old Willets Path, P.O. Box 12308, Hauppauge, NY 11788-0615 (631-234-0500; FAX: 631-234-0691; www.mixers.com)

ROSS MIXERS, 710 Old Willets Path, P.O. Box 12308, Hauppauge, NY 11788-0615 (631-234-0500; FAX: 631-234-0691; www.mixers.com)

ROSS MIXERS, 710 Old Willets Path, P.O. Box 12308, Hauppauge, NY 11788-0615 (631-234-0500; FAX: 631-234-0691; www.mixers.com)

Reactors, fluid bed



PARR INSTRUMENT COMPANY, 211 53rd Street, Moline, IL 61265 (309-762-7716; FAX: 309-762-9453; lisa.randolph@parrinst.com; www.parrinst.com)

Reactors, gas-liquid

Buchiglas USA Corp., Farmingdale, NY
EKATO RUEHR- UND MISCHTECHNIK GMBH, Hohe-Flum-Str.37, Schopfheim, Germany D-79650 (+49 7622 290; FAX: +49 7622 29 213; www.ekato.com)
 — See our ad on page 84
FLUID LINE PRODUCTS INC., 38273 Western Pkwy., P.O. Box 1000, Willoughby, OH 44096 (440-946-9470; FAX: 440-946-9472; www.fluidline.com)
 Fluitron, Inc., Ivyland, PA
PARR INSTRUMENT COMPANY, 211 53rd Street, Moline, IL 61265 (309-762-7716; FAX: 309-762-9453; lisa.randolph@parrinst.com; www.parrinst.com)

Reactors, jacketed

Buchiglas USA Corp., Farmingdale, NY
 Fluitron, Inc., Ivyland, PA
PARR INSTRUMENT COMPANY, 211 53rd Street, Moline, IL 61265 (309-762-7716; FAX: 309-762-9453; lisa.randolph@parrinst.com; www.parrinst.com)
POPE SCIENTIFIC, INC., P.O. Box 80018, 351 N. Dekora Woods Blvd., Saukville, WI 53080 (262-268-9300; FAX: 262-268-9400; info@popeinc.com; www.popeinc.com)
ROSS MIXERS, 710 Old Willets Path, P.O. Box 12308, Hauppauge, NY 11788-0615 (631-234-0500; FAX: 631-234-0691; www.mixers.com)

Reactors, jacketed, dimple

POPE SCIENTIFIC, INC., P.O. Box 80018, 351 N. Dekora Woods Blvd., Saukville, WI 53080 (262-268-9300; FAX: 262-268-9400; info@popeinc.com; www.popeinc.com)
ROSS MIXERS, 710 Old Willets Path, P.O. Box 12308, Hauppauge, NY 11788-0615 (631-234-0500; FAX: 631-234-0691; www.mixers.com)

Reactors, jacketed, half-pipe

ROSS MIXERS, 710 Old Willets Path, P.O. Box 12308, Hauppauge, NY 11788-0615 (631-234-0500; FAX: 631-234-0691; www.mixers.com)

Reactors, lined, glass

Buchiglas USA Corp., Farmingdale, NY
PARR INSTRUMENT COMPANY, 211 53rd Street, Moline, IL 61265 (309-762-7716; FAX: 309-762-9453; lisa.randolph@parrinst.com; www.parrinst.com)

Reactors, lined, metal

Fluitron, Inc., Ivyland, PA
PARR INSTRUMENT COMPANY, 211 53rd Street, Moline, IL 61265 (309-762-7716; FAX: 309-762-9453; lisa.randolph@parrinst.com; www.parrinst.com)
POPE SCIENTIFIC, INC., P.O. Box 80018, 351 N. Dekora Woods Blvd., Saukville, WI 53080 (262-268-9300; FAX: 262-268-9400; info@popeinc.com; www.popeinc.com)

Reactors, loop

PARR INSTRUMENT COMPANY, 211 53rd Street, Moline, IL 61265 (309-762-7716; FAX: 309-762-9453; lisa.randolph@parrinst.com; www.parrinst.com)

Reactors, pilot plant

Buchiglas USA Corp., Farmingdale, NY
EKATO RUEHR- UND MISCHTECHNIK GMBH, Hohe-Flum-Str.37, Schopfheim, Germany D-79650 (+49 7622 290; FAX: +49 7622 29 213; www.ekato.com)
 — See our ad on page 84
FLUID LINE PRODUCTS INC., 38273 Western Pkwy., P.O. Box 1000, Willoughby, OH 44096 (440-946-9470; FAX: 440-946-9472; www.fluidline.com)
 Fluitron, Inc., Ivyland, PA
PARR INSTRUMENT COMPANY, 211 53rd Street, Moline, IL 61265 (309-762-7716; FAX: 309-762-9453; lisa.randolph@parrinst.com; www.parrinst.com)
POPE SCIENTIFIC, INC., P.O. Box 80018, 351 N. Dekora Woods Blvd., Saukville, WI 53080 (262-268-9300; FAX: 262-268-9400; info@popeinc.com; www.popeinc.com)

Reactors, rotary blade

Fluitron, Inc., Ivyland, PA
PARR INSTRUMENT COMPANY, 211 53rd Street, Moline, IL 61265 (309-762-7716; FAX: 309-762-9453; lisa.randolph@parrinst.com; www.parrinst.com)

ROSS MIXERS, 710 Old Willets Path, P.O. Box 12308, Hauppauge, NY 11788-0615 (631-234-0500; FAX: 631-234-0691; www.mixers.com)

Separators

Filtration Technology Corporation, Houston, TX
KOCH-GLITSCH, INC., 4111 E. 37th St. N., Wichita, KS 67220 (316-828-5110; FAX: 316-828-7985)
 — See our ad inside front cover

Vessels, plastic lined

POPE SCIENTIFIC, INC., P.O. Box 80018, 351 N. Dekora Woods Blvd., Saukville, WI 53080 (262-268-9300; FAX: 262-268-9400; info@popeinc.com; www.popeinc.com)

Vessels, pressure, cryogenic

POPE SCIENTIFIC, INC., P.O. Box 80018, 351 N. Dekora Woods Blvd., Saukville, WI 53080 (262-268-9300; FAX: 262-268-9400; info@popeinc.com; www.popeinc.com)

Vessels, pressure, custom

Buchiglas USA Corp., Farmingdale, NY
 Fluitron, Inc., Ivyland, PA
JLS INTERNATIONAL, INC., 381 Fawn Lane, West Jefferson, NC 28694 (336-877-5571; FAX: 336-877-5579)
PARR INSTRUMENT COMPANY, 211 53rd Street, Moline, IL 61265 (309-762-7716; FAX: 309-762-9453; lisa.randolph@parrinst.com; www.parrinst.com)
POPE SCIENTIFIC, INC., P.O. Box 80018, 351 N. Dekora Woods Blvd., Saukville, WI 53080 (262-268-9300; FAX: 262-268-9400; info@popeinc.com; www.popeinc.com)
ROSS MIXERS, 710 Old Willets Path, P.O. Box 12308, Hauppauge, NY 11788-0615 (631-234-0500; FAX: 631-234-0691; www.mixers.com)

Vessels, pressure, jacketed, dimple

GEMCO, the worldwide mixing and drying authority, Middlesex, NJ
POPE SCIENTIFIC, INC., P.O. Box 80018, 351 N. Dekora Woods Blvd., Saukville, WI 53080 (262-268-9300; FAX: 262-268-9400; info@popeinc.com; www.popeinc.com)
ROSS MIXERS, 710 Old Willets Path, P.O. Box 12308, Hauppauge, NY 11788-0615 (631-234-0500; FAX: 631-234-0691; www.mixers.com)

Vessels, pressure, multilayered heavy wall

Fluitron, Inc., Ivyland, PA
JLS INTERNATIONAL, INC., 381 Fawn Lane, West Jefferson, NC 28694 (336-877-5571; FAX: 336-877-5579)

Vessels, pressure, safety sight glass

PARR INSTRUMENT COMPANY, 211 53rd Street, Moline, IL 61265 (309-762-7716; FAX: 309-762-9453; lisa.randolph@parrinst.com; www.parrinst.com)

REACTION & SEPARATION EQUIPMENT, OTHER

Aerators

KOERTING HANNOVER GMBH, Badenstedter Str. 56, Hannover, Germany 30453 (0511-2129-0; FAX: 0511-2129-223)
 — See our ad on page 69

Membrane systems for liquids

GEA GROUP, 9165 Rumsey Road, Columbia, MD 21045 (800-722-6622; www.gea.com)
 — See our ad on page 23
INEOS Electrochemical Solutions, Runcorn, Cheshire, United Kingdom

Monomer-recovery systems

BUSS-SMS-CANZLER GMBH, Kaiserstr. 13-15, Butzbach, Germany 35510 (49-6033-85-0; FAX: 49-6033-85-249)
POPE SCIENTIFIC, INC., P.O. Box 80018, 351 N. Dekora Woods Blvd., Saukville, WI 53080 (262-268-9300; FAX: 262-268-9400; info@popeinc.com; www.popeinc.com)

Nozzles, mixing

KOERTING HANNOVER GMBH, Badenstedter Str. 56, Hannover, Germany 30453 (0511-2129-0; FAX: 0511-2129-223)
 — See our ad on page 69
ROSS MIXERS, 710 Old Willets Path, P.O. Box 12308, Hauppauge, NY 11788-0615 (631-234-0500; FAX: 631-234-0691; www.mixers.com)

Nozzles, spray

KOERTING HANNOVER GMBH, Badenstedter Str. 56, Hannover, Germany 30453 (0511-2129-0; FAX: 0511-2129-223)
 — See our ad on page 69

Pervaporation equipment

CAST-X Circulation Heaters, Batavia, IL

Separators, fluidizing

KOCH-GLITSCH, INC., 4111 E. 37th St. N., Wichita, KS 67220 (316-828-5110; FAX: 316-828-7985)
 — See our ad inside front cover

Solvent recovery systems

BUSS-SMS-CANZLER GMBH, Kaiserstr. 13-15, Butzbach, Germany 35510 (49-6033-85-0; FAX: 49-6033-85-249)
 CAST-X Circulation Heaters, Batavia, IL
CR CLEAN AIR, Six Campus Drive, Parsippany, NJ 07054 (973-947-8787; FAX: 908-232-2146; info@crleanair.com; www.crleanair.com)
GEA GROUP, 9165 Rumsey Road, Columbia, MD 21045 (800-722-6622; www.gea.com)
 — See our ad on page 23

POPE SCIENTIFIC, INC., P.O. Box 80018, 351 N. Dekora Woods Blvd., Saukville, WI 53080 (262-268-9300; FAX: 262-268-9400; info@popeinc.com; www.popeinc.com)

ROSS MIXERS, 710 Old Willets Path, P.O. Box 12308, Hauppauge, NY 11788-0615 (631-234-0500; FAX: 631-234-0691; www.mixers.com)

Supercritical fluid extraction processing

PARR INSTRUMENT COMPANY, 211 53rd Street, Moline, IL 61265 (309-762-7716; FAX: 309-762-9453; lisa.randolph@parrinst.com; www.parrinst.com)

SCREENING EQUIPMENT

Screening

ANDRITZ SEPARATION, ANDRITZ AG, Stattegger Strasse 18, Graz, Austria 8045 (+43 050 8050; separation@andritz.com; www.andritz.com/separation)

Screens, perforated plate

ANDRITZ SEPARATION, ANDRITZ AG, Stattegger Strasse 18, Graz, Austria 8045 (+43 050 8050; separation@andritz.com; www.andritz.com/separation)

Screens, vibrating

DYNAMIC AIR INC., 1125 Willow Lake Blvd., St. Paul, MN 55110-5193 (651-484-2900; FAX: 651-484-7015; www.dynamicair.com)

Separators, magnetic

METSO MINERALS INDUSTRIES, INC., 2715 Pleasant Valley Road, York, PA 17402 (717-843-8671; FAX: 717-845-5154; www.metso.com)
 — See our ad on page 39

Wire mesh

KOCH-GLITSCH, INC., 4111 E. 37th St. N., Wichita, KS 67220 (316-828-5110; FAX: 316-828-7985)
 — See our ad inside front cover

SCRUBBERS

Scrubbers, cyclone

CR CLEAN AIR, Six Campus Drive, Parsippany, NJ 07054 (973-947-8787; FAX: 908-232-2146; info@crleanair.com; www.crleanair.com)
KOCH-GLITSCH, INC., 4111 E. 37th St. N., Wichita, KS 67220 (316-828-5110; FAX: 316-828-7985)
 — See our ad inside front cover

Scrubbers, fluidized bed

CAST-X Circulation Heaters, Batavia, IL

Scrubbers, fume, gas



CR CLEAN AIR, Six Campus Drive, Parsippany, NJ 07054 (973-947-8787; FAX: 908-232-2146; info@crleanair.com; www.crleanair.com)
GEA GROUP, 9165 Rumsey Road, Columbia, MD 21045 (800-722-6622; www.gea.com)
 — See our ad on page 23

Scrubbers, impingement baffle

CR CLEAN AIR, Six Campus Drive, Parsippany, NJ 07054 (973-947-8787; FAX: 908-232-2146; info@crcleanair.com; www.crcleanair.com)

Scrubbers, jet



CR CLEAN AIR, Six Campus Drive, Parsippany, NJ 07054 (973-947-8787; FAX: 908-232-2146; info@crcleanair.com; www.crcleanair.com)

GEA GROUP, 9165 Rumsey Road, Columbia, MD 21045 (800-722-6622; www.gea.com)
—See our ad on page 23

KOERTING HANNOVER GMBH, Badenstedter Str. 56, Hannover, Germany 30453 (0511-2129-0; FAX: 0511-2129-223)
—See our ad on page 69

Scrubbers, oil mist

CR CLEAN AIR, Six Campus Drive, Parsippany, NJ 07054 (973-947-8787; FAX: 908-232-2146; info@crcleanair.com; www.crcleanair.com)

KOCH-GLITSCH, INC., 4111 E. 37th St. N., Wichita, KS 67220 (316-828-5110; FAX: 316-828-7985)
—See our ad inside front cover

Scrubbers, orifice

CR CLEAN AIR, Six Campus Drive, Parsippany, NJ 07054 (973-947-8787; FAX: 908-232-2146; info@crcleanair.com; www.crcleanair.com)

Scrubbers, packed column

Buchiglas USA Corp., Farmingdale, NY
CR CLEAN AIR, Six Campus Drive, Parsippany, NJ 07054 (973-947-8787; FAX: 908-232-2146; info@crcleanair.com; www.crcleanair.com)

GEA GROUP, 9165 Rumsey Road, Columbia, MD 21045 (800-722-6622; www.gea.com)
—See our ad on page 23

KOCH-GLITSCH, INC., 4111 E. 37th St. N., Wichita, KS 67220 (316-828-5110; FAX: 316-828-7985)
—See our ad inside front cover

Scrubbers, spray

CR CLEAN AIR, Six Campus Drive, Parsippany, NJ 07054 (973-947-8787; FAX: 908-232-2146; info@crcleanair.com; www.crcleanair.com)

Scrubbers, venturi



CR CLEAN AIR, Six Campus Drive, Parsippany, NJ 07054 (973-947-8787; FAX: 908-232-2146; info@crcleanair.com; www.crcleanair.com)

GEA GROUP, 9165 Rumsey Road, Columbia, MD 21045 (800-722-6622; www.gea.com)
—See our ad on page 23

KOERTING HANNOVER GMBH, Badenstedter Str. 56, Hannover, Germany 30453 (0511-2129-0; FAX: 0511-2129-223)
—See our ad on page 69

SIZE REDUCTION EQUIPMENT

Comminutors

FRITSCH GmbH - Milling and Sizing, Idar-Oberstein, Idar-Oberstein, Germany

Crushers, impact

Stedman Machine Company, Aurora, IN

Crushers, jaw

FRITSCH GmbH - Milling and Sizing, Idar-Oberstein, Idar-Oberstein, Germany
FRITSCH Milling & Sizing, Inc., Pittsboro, NC

Crushers, rotary

Munson Machinery Company, Inc., Utica, NY

Lumpbreakers

PAUL O. ABBE, 201 Hanson Ct. Suite 125, Wood Dale, IL 60191 (630-350-3012; FAX: 630-238-7584)
—See our ad on page 15

DYNAMIC AIR INC., 1125 Willow Lake Blvd., St. Paul, MN 55110-5193 (651-484-2900; FAX: 651-484-7015; www.dynamicair.com)

JAYGO, INC., 7 Emery Ave., Randolph, NJ 07869 (908-688-3600; FAX: 908-688-6060)

Palamatic Process Inc, Philadelphia, PA

Lumpbreakers for solid & liquid systems

ROSS MIXERS, 710 Old Willets Path, P.O. Box 12308, Hauppauge, NY 11788-0615 (631-234-0500; FAX: 631-234-0691; www.mixers.com)

Mills, attrition

PAUL O. ABBE, 201 Hanson Ct. Suite 125, Wood Dale, IL 60191 (630-350-3012; FAX: 630-238-7584)
—See our ad on page 15

Mills, ball

PAUL O. ABBE, 201 Hanson Ct. Suite 125, Wood Dale, IL 60191 (630-350-3012; FAX: 630-238-7584)
—See our ad on page 15

FRITSCH Milling & Sizing, Inc., Pittsboro, NC
JAYGO, INC., 7 Emery Ave., Randolph, NJ 07869 (908-688-3600; FAX: 908-688-6060)

METSO MINERALS INDUSTRIES, INC., 2715 Pleasant Valley Road, York, PA 17402 (717-843-8671; FAX: 717-845-5154; www.metso.com)
—See our ad on page 39

Mills, cage

Stedman Machine Company, Aurora, IN

Mills, colloid

Admix Inc., Londonderry, NH
ROSS MIXERS, 710 Old Willets Path, P.O. Box 12308, Hauppauge, NY 11788-0615 (631-234-0500; FAX: 631-234-0691; www.mixers.com)

Mills, cone

SCHENCK PROCESS, 7901 NW 107th Terrace, Kansas City, MO 64153 (816-891-9300; FAX: 816-891-8336; www.schenckprocess.com)

Mills, disc

ROSS MIXERS, 710 Old Willets Path, P.O. Box 12308, Hauppauge, NY 11788-0615 (631-234-0500; FAX: 631-234-0691; www.mixers.com)

Mills, grinding

PAUL O. ABBE, 201 Hanson Ct. Suite 125, Wood Dale, IL 60191 (630-350-3012; FAX: 630-238-7584)
—See our ad on page 15

FRITSCH Milling & Sizing, Inc., Pittsboro, NC
JAYGO, INC., 7 Emery Ave., Randolph, NJ 07869 (908-688-3600; FAX: 908-688-6060)

METSO MINERALS INDUSTRIES, INC., 2715 Pleasant Valley Road, York, PA 17402 (717-843-8671; FAX: 717-845-5154; www.metso.com)
—See our ad on page 39

ROSS MIXERS, 710 Old Willets Path, P.O. Box 12308, Hauppauge, NY 11788-0615 (631-234-0500; FAX: 631-234-0691; www.mixers.com)

SCHENCK PROCESS, 7901 NW 107th Terrace, Kansas City, MO 64153 (816-891-9300; FAX: 816-891-8336; www.schenckprocess.com)

Mills, hammer

FRITSCH Milling & Sizing, Inc., Pittsboro, NC
Stedman Machine Company, Aurora, IN

Mills, homogenizing

Admix Inc., Londonderry, NH
FRITSCH Milling & Sizing, Inc., Pittsboro, NC
ROSS MIXERS, 710 Old Willets Path, P.O. Box 12308, Hauppauge, NY 11788-0615 (631-234-0500; FAX: 631-234-0691; www.mixers.com)

Mills, impact

Palamatic Process Inc, Philadelphia, PA
Stedman Machine Company, Aurora, IN

Mills, jacketed ball

PAUL O. ABBE, 201 Hanson Ct. Suite 125, Wood Dale, IL 60191 (630-350-3012; FAX: 630-238-7584)
—See our ad on page 15

JAYGO, INC., 7 Emery Ave., Randolph, NJ 07869 (908-688-3600; FAX: 908-688-6060)

Mills, other

Admix Inc., Londonderry, NH

Mills, rod

PAUL O. ABBE, 201 Hanson Ct. Suite 125, Wood Dale, IL 60191 (630-350-3012; FAX: 630-238-7584)
—See our ad on page 15

Mills, roller

ROSS MIXERS, 710 Old Willets Path, P.O. Box 12308, Hauppauge, NY 11788-0615 (631-234-0500; FAX: 631-234-0691; www.mixers.com)

Mills, vertical

Stedman Machine Company, Aurora, IN

TOWERS & COLUMNS

Columns, absorption or adsorption

GEA GROUP, 9165 Rumsey Road, Columbia, MD 21045 (800-722-6622; www.gea.com)
—See our ad on page 23

KOCH-GLITSCH, INC., 4111 E. 37th St. N., Wichita, KS 67220 (316-828-5110; FAX: 316-828-7985)
—See our ad inside front cover

Columns, bubble cap

KOCH-GLITSCH, INC., 4111 E. 37th St. N., Wichita, KS 67220 (316-828-5110; FAX: 316-828-7985)
—See our ad inside front cover

Columns, custom fabricated

JLS INTERNATIONAL, INC., 381 Fawn Lane, West Jefferson, NC 28694 (336-877-5571; FAX: 336-877-5579)
POPE SCIENTIFIC, INC., P.O. Box 80018, 351 N. Dekora Woods Blvd., Saukville, WI 53080 (262-268-9300; FAX: 262-268-9400; info@popeinc.com; www.popeinc.com)

Columns, packed

KOCH-GLITSCH, INC., 4111 E. 37th St. N., Wichita, KS 67220 (316-828-5110; FAX: 316-828-7985)
—See our ad inside front cover

PARR INSTRUMENT COMPANY, 211 53rd Street, Moline, IL 61265 (309-762-7716; FAX: 309-762-9453; lisa.randolph@parrinst.com; www.parrinst.com)

POPE SCIENTIFIC, INC., P.O. Box 80018, 351 N. Dekora Woods Blvd., Saukville, WI 53080 (262-268-9300; FAX: 262-268-9400; info@popeinc.com; www.popeinc.com)

SULZER CHEMTECH, Neuwiesenstrasse 15, Winterthur, Switzerland 8401 (41522623722; www.sulzer.com)

Columns, vacuum

KOCH-GLITSCH, INC., 4111 E. 37th St. N., Wichita, KS 67220 (316-828-5110; FAX: 316-828-7985)
—See our ad inside front cover

POPE SCIENTIFIC, INC., P.O. Box 80018, 351 N. Dekora Woods Blvd., Saukville, WI 53080 (262-268-9300; FAX: 262-268-9400; info@popeinc.com; www.popeinc.com)

Columns, valve tray

KOCH-GLITSCH, INC., 4111 E. 37th St. N., Wichita, KS 67220 (316-828-5110; FAX: 316-828-7985)
—See our ad inside front cover

Distillation columns, automatic packaged unit

POPE SCIENTIFIC, INC., P.O. Box 80018, 351 N. Dekora Woods Blvd., Saukville, WI 53080 (262-268-9300; FAX: 262-268-9400; info@popeinc.com; www.popeinc.com)

Distillation columns, molecular distillation

BUSS-SMS-CANZLER GMBH, Kaiserstr. 13-15, Butzbach, Germany 35510 (49-6033-85-0; FAX: 49-6033-85-249)

GEA GROUP, 9165 Rumsey Road, Columbia, MD 21045 (800-722-6622; www.gea.com)
—See our ad on page 23

POPE SCIENTIFIC, INC., P.O. Box 80018, 351 N. Dekora Woods Blvd., Saukville, WI 53080 (262-268-9300; FAX: 262-268-9400; info@popeinc.com; www.popeinc.com)

Distillation columns, sieve tray

GEA GROUP, 9165 Rumsey Road, Columbia, MD 21045 (800-722-6622; www.gea.com)
—See our ad on page 23

KOCH-GLITSCH, INC., 4111 E. 37th St. N., Wichita, KS 67220 (316-828-5110; FAX: 316-828-7985)
—See our ad inside front cover

Distillation columns, steam stripping

GEA GROUP, 9165 Rumsey Road, Columbia, MD 21045 (800-722-6622; www.gea.com)
—See our ad on page 23

PRODUCT DIRECTORY

KOCH-GLITSCH, INC., 4111 E. 37th St. N., Wichita, KS
67220 (316-828-5110; FAX: 316-828-7985)
—See our ad inside front cover

Distillation columns, vapor compression

GEA GROUP, 9165 Rumsey Road, Columbia, MD 21045
(800-722-6622; www.gea.com)
—See our ad on page 23

Tower parts & accessories

KOCH-GLITSCH, INC., 4111 E. 37th St. N., Wichita, KS
67220 (316-828-5110; FAX: 316-828-7985)
—See our ad inside front cover

WATER TREATMENT EQUIPMENT

Boiler feedwater systems

INDECK POWER EQUIPMENT CO., 1111 Willis Ave.
(CE), Wheeling, IL 60090 (847-541-8300; FAX: 847-541-9984; www.indeck.com)
—See our ad on page 15

Desalination units

GEA GROUP, 9165 Rumsey Road, Columbia, MD 21045
(800-722-6622; www.gea.com)
—See our ad on page 23

HENGFENGTAI PRECISION MACHINERY Co. for MIXING
and THICKENING SOLUTIONS since 1991, Wenzhou,
Wenzhou, China

Hypochlorinators

BLUE-WHITE INDUSTRIES, 5300 Business Drive,
Huntington Beach, CA 92649 (714-893-8529; FAX:
714-895-9492; sales@blue-white.com; www.blue-
white.com)

Resins, ion exchange

LANXESS CORPORATION, 111 RIDC Park West Drive,
Pittsburgh, PA 15275 (412-809-1000; info@lanxess.
com; www.lanxess.us)

Reverse osmosis systems

GEA GROUP, 9165 Rumsey Road, Columbia, MD 21045
(800-722-6622; www.gea.com)
—See our ad on page 23
Toray Membrane USA, Inc.

Processing equipment

Water pollution systems

ANDRITZ SEPARATION, ANDRITZ AG, Stattegger
Strasse 18, Graz, Austria 8045 (+43 050 8050; separa-
tion@andritz.com; www.andritz.com/separation)
HONEYWELL, 101 Columbia Rd., Morristown, NJ 07962
(973-455-2000; FAX: 973-455-5722)

Water treatment control equipment

SIERRA INSTRUMENTS, INC., 5 Harris Ct., Bldg. L,
Monterey, CA 93940 (831-373-0200; FAX: 831-373-
4402; info@sierrainstruments.com; www.sierrainstru-
ments.com)

Water-conditioning package systems

Water Heating Direct, Fort Worth, TX

Get *Chemical Engineering's* Plant Cost Index to improve plant cost estimates...and delivered in advance of the print edition!



For more than 40 years, chemical process industries professionals- engineers, manager and technicians, have used Chemical Engineering's Plant Cost Index to adjust process plant construction costs from one period to another.

This database includes all annual archives (1947 to present) and monthly data archives (1970 to present). Instead of waiting more than two weeks for the print or online version of Chemical Engineering to arrive, subscribers can access new data as soon as it's calculated.

	Sep '06 Prelim.	Aug '06 Final	Sep '05 Final
CE Index	513.1	510.0	467.2
Equipment	606.5	602.3	541.2
Heat Exchanges and Tanks	565.1	560.9	509.2
Process Machinery	559.6	556.2	521.7
Pipe, valves and fittings	734.7	731.7	620.8
Process Instruments	441.4	437.2	379.5
Pumps and Compressions	788.9	788.3	756.3
Electrical equipment	418.9	414.2	374.6
Structural supports	643.7	637.7	579.3
Construction Labor	314.7	312.9	309.1
Buildings	476.9	475.2	444.7
Engineering Supervision	350.7	351.9	346.9

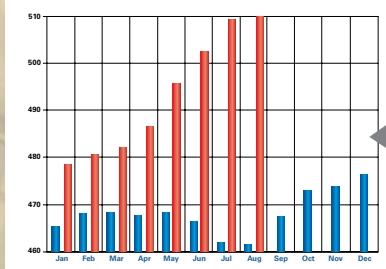

Resources included with Chemical Engineering's Plant Cost Index:

- Electronic notification of monthly updates as soon as they are available
- All annual data archives (1947 to present)
- Monthly data archives (1970 to present)
- Option to download in Excel format

Subscribe today at www.chemengonline.com/pci

6

ENGINEERING MATERIALS

- 96 Associations
- 96 Ceramics, including glass
- 96 Composites
- 96 Copper & copper alloys
- 96 Insulation materials
- 96 Iron & iron alloys
- 96 Lubricants
- 96 Metals & alloys, other nonferrous
- 97 Nickel & nickel alloys
- 97 Plastics materials
- 97 Protective coatings & linings
- 97 Refractory materials
- 97 Rubber & rubberlike materials
- 97 Steels

ASSOCIATIONS

DECHEMA E.V., Theodor-Heuss-Allee 25, Frankfurt am Main, Germany 60486 (49-69-75-64-0; FAX: 49-69-75-64-201; www.dechema.de)
— See our ad on page 22

CERAMICS, INCLUDING GLASS

Carbides

AMERICAN ELEMENTS, Los Angeles, CA 90024 (310-208-0551; FAX: 310-208-0351; www.americanelements.com)
— See our ad on Back Cover

Carbon & graphite

AMERICAN ELEMENTS, Los Angeles, CA 90024 (310-208-0551; FAX: 310-208-0351; www.americanelements.com)
— See our ad on Back Cover

Fused silica

AMERICAN ELEMENTS, Los Angeles, CA 90024 (310-208-0551; FAX: 310-208-0351; www.americanelements.com)
— See our ad on Back Cover

Powders, ceramic

AMERICAN ELEMENTS, Los Angeles, CA 90024 (310-208-0551; FAX: 310-208-0351; www.americanelements.com)
— See our ad on Back Cover

Silicon carbide

AMERICAN ELEMENTS, Los Angeles, CA 90024 (310-208-0551; FAX: 310-208-0351; www.americanelements.com)
— See our ad on Back Cover

COMPOSITES

Ceramic metals

AMERICAN ELEMENTS, Los Angeles, CA 90024 (310-208-0551; FAX: 310-208-0351; www.americanelements.com)
— See our ad on Back Cover

COPPER & COPPER ALLOYS

Brass

AMERICAN ELEMENTS, Los Angeles, CA 90024 (310-208-0551; FAX: 310-208-0351; www.americanelements.com)
— See our ad on Back Cover

Bronze

AMERICAN ELEMENTS, Los Angeles, CA 90024 (310-208-0551; FAX: 310-208-0351; www.americanelements.com)
— See our ad on Back Cover

Copper

AMERICAN ELEMENTS, Los Angeles, CA 90024 (310-208-0551; FAX: 310-208-0351; www.americanelements.com)
— See our ad on Back Cover

Copper alloys, other

AMERICAN ELEMENTS, Los Angeles, CA 90024 (310-208-0551; FAX: 310-208-0351; www.americanelements.com)
— See our ad on Back Cover

INSULATION MATERIALS

Insulation, high temperature

ACS Industries Inc., Lincoln, RI

IRON & IRON ALLOYS

Cast irons

AMERICAN ELEMENTS, Los Angeles, CA 90024 (310-208-0551; FAX: 310-208-0351; www.americanelements.com)
— See our ad on Back Cover

Cast irons, alloy

AMERICAN ELEMENTS, Los Angeles, CA 90024 (310-208-0551; FAX: 310-208-0351; www.americanelements.com)
— See our ad on Back Cover

Cast irons, high-silicon

AMERICAN ELEMENTS, Los Angeles, CA 90024 (310-208-0551; FAX: 310-208-0351; www.americanelements.com)
— See our ad on Back Cover

Ductile iron

AMERICAN ELEMENTS, Los Angeles, CA 90024 (310-208-0551; FAX: 310-208-0351; www.americanelements.com)
— See our ad on Back Cover

LUBRICANTS

Lubricants, engine oil

LANXESS CORPORATION, 111 RIDC Park West Drive, Pittsburgh, PA 15275 (412-809-1000; info@lanxess.com; www.lanxess.us)

Lubricants, greases

Cortec Corp., St. Paul, MN
LANXESS CORPORATION, 111 RIDC Park West Drive, Pittsburgh, PA 15275 (412-809-1000; info@lanxess.com; www.lanxess.us)

Lubricants, industrial oils

LANXESS

Energizing Chemistry

LANXESS CORPORATION, 111 RIDC Park West Drive, Pittsburgh, PA 15275 (412-809-1000; info@lanxess.com; www.lanxess.us)

Lubricants, process oils

LANXESS CORPORATION, 111 RIDC Park West Drive, Pittsburgh, PA 15275 (412-809-1000; info@lanxess.com; www.lanxess.us)

METALS & ALLOYS, OTHER NONFERROUS

Chromium & alloys

AMERICAN ELEMENTS, Los Angeles, CA 90024 (310-208-0551; FAX: 310-208-0351; www.americanelements.com)
— See our ad on Back Cover

Cobalt alloys

AMERICAN ELEMENTS, Los Angeles, CA 90024 (310-208-0551; FAX: 310-208-0351; www.americanelements.com)
— See our ad on Back Cover

Gold & alloys

AMERICAN ELEMENTS, Los Angeles, CA 90024 (310-208-0551; FAX: 310-208-0351; www.americanelements.com)
— See our ad on Back Cover

Indium & alloys

AMERICAN ELEMENTS, Los Angeles, CA 90024 (310-208-0551; FAX: 310-208-0351; www.americanelements.com)
— See our ad on Back Cover

Lead & alloys

AMERICAN ELEMENTS, Los Angeles, CA 90024 (310-208-0551; FAX: 310-208-0351; www.americanelements.com)
— See our ad on Back Cover

Molybdenum & alloys

AMERICAN ELEMENTS, Los Angeles, CA 90024 (310-208-0551; FAX: 310-208-0351; www.americanelements.com)
— See our ad on Back Cover

Niobium

AMERICAN ELEMENTS, Los Angeles, CA 90024 (310-208-0551; FAX: 310-208-0351; www.americanelements.com)
— See our ad on Back Cover

Palladium & alloys

AMERICAN ELEMENTS, Los Angeles, CA 90024 (310-208-0551; FAX: 310-208-0351; www.americanelements.com)
— See our ad on Back Cover

Platinum & alloys

AMERICAN ELEMENTS, Los Angeles, CA 90024 (310-208-0551; FAX: 310-208-0351; www.americanelements.com)
— See our ad on Back Cover

Silver & alloys

AMERICAN ELEMENTS, Los Angeles, CA 90024 (310-208-0551; FAX: 310-208-0351; www.americanelements.com)
— See our ad on Back Cover

Tantalum & alloys

AMERICAN ELEMENTS, Los Angeles, CA 90024 (310-208-0551; FAX: 310-208-0351; www.americanelements.com)
— See our ad on Back Cover

Tin & alloys

AMERICAN ELEMENTS, Los Angeles, CA 90024 (310-208-0551; FAX: 310-208-0351; www.americanelements.com)
— See our ad on Back Cover

Titanium & alloys

AMERICAN ELEMENTS, Los Angeles, CA 90024 (310-208-0551; FAX: 310-208-0351; www.americanelements.com)
— See our ad on Back Cover

Tungsten & alloys

AMERICAN ELEMENTS, Los Angeles, CA 90024 (310-208-0551; FAX: 310-208-0351; www.americanelements.com)
— See our ad on Back Cover

Zinc & alloys

AMERICAN ELEMENTS, Los Angeles, CA 90024 (310-208-0551; FAX: 310-208-0351; www.americanelements.com)
— See our ad on Back Cover

Zirconium

AMERICAN ELEMENTS, Los Angeles, CA 90024 (310-208-0551; FAX: 310-208-0351; www.americanelements.com)
— See our ad on Back Cover

NICKEL & NICKEL ALLOYS

Nickel

AMERICAN ELEMENTS, Los Angeles, CA 90024 (310-208-0551; FAX: 310-208-0351; www.americanelements.com)
— See our ad on Back Cover

Nickel alloys

AMERICAN ELEMENTS, Los Angeles, CA 90024 (310-208-0551; FAX: 310-208-0351; www.americanelements.com)
— See our ad on Back Cover

PLASTICS MATERIALS

Fluorocarbons

ARKEMA INC., 900 First Avenue, King of Prussia, PA 19406 (610-205-7000; FAX: 610-205-7913)
— See our ad on page 3

Nylon

LANXESS CORPORATION, 111 RIDC Park West Drive, Pittsburgh, PA 15275 (412-809-1000; info@lanxess.com; www.lanxess.us)

Plastics, other

Cortec Corp., St. Paul, MN



LANXESS CORPORATION, 111 RIDC Park West Drive, Pittsburgh, PA 15275 (412-809-1000; info@lanxess.com; www.lanxess.us)

Polyesters

LANXESS CORPORATION, 111 RIDC Park West Drive, Pittsburgh, PA 15275 (412-809-1000; info@lanxess.com; www.lanxess.us)

THYSSENKRUPP INDUSTRIAL SOLUTIONS AG, thyssenkrupp Allee 1, Essen, Germany 45143 (49-201 8440; info.industrial-solutions@thyssenkrupp.com; www.thyssenkrupp-industrial-solutions.com)

Polyethylenes

Cortec Corp., St. Paul, MN

THYSSENKRUPP INDUSTRIAL SOLUTIONS AG, thyssenkrupp Allee 1, Essen, Germany 45143 (49-201 8440; info.industrial-solutions@thyssenkrupp.com; www.thyssenkrupp-industrial-solutions.com)

Polypropylenes

THYSSENKRUPP INDUSTRIAL SOLUTIONS AG, thyssenkrupp Allee 1, Essen, Germany 45143 (49-201 8440; info.industrial-solutions@thyssenkrupp.com; www.thyssenkrupp-industrial-solutions.com)

Engineering materials

PROTECTIVE COATINGS & LININGS

Coatings, acrylic

Cortec Corp., St. Paul, MN

Coatings, epoxy

Cortec Corp., St. Paul, MN

REFRACTORY MATERIALS

Anchors, refractory

ZIRCAR Refractory Composites Inc., Florida, NY

Castables

AMERICAN ELEMENTS, Los Angeles, CA 90024 (310-208-0551; FAX: 310-208-0351; www.americanelements.com)
— See our ad on Back Cover

Refractories

AMERICAN ELEMENTS, Los Angeles, CA 90024 (310-208-0551; FAX: 310-208-0351; www.americanelements.com)
— See our ad on Back Cover

ZIRCAR Refractory Composites Inc., Florida, NY

Refractory mortars & cements

ZIRCAR Refractory Composites Inc., Florida, NY

RUBBER & RUBBERLIKE MATERIALS

Rubber, urethane

LANXESS CORPORATION, 111 RIDC Park West Drive, Pittsburgh, PA 15275 (412-809-1000; info@lanxess.com; www.lanxess.us)

STEELS

Carbon steels

AMERICAN ELEMENTS, Los Angeles, CA 90024 (310-208-0551; FAX: 310-208-0351; www.americanelements.com)
— See our ad on Back Cover

High alloy steels

AMERICAN ELEMENTS, Los Angeles, CA 90024 (310-208-0551; FAX: 310-208-0351; www.americanelements.com)
— See our ad on Back Cover

Low alloy steels

AMERICAN ELEMENTS, Los Angeles, CA 90024 (310-208-0551; FAX: 310-208-0351; www.americanelements.com)
— See our ad on Back Cover

Medium alloy steels

AMERICAN ELEMENTS, Los Angeles, CA 90024 (310-208-0551; FAX: 310-208-0351; www.americanelements.com)
— See our ad on Back Cover

7

PLANT MAINTENANCE

- 98 Associations
- 98 Cleaning equipment & services
- 98 Equipment repair & rebuilding
- 98 Maintenance tools & equipment & replacement parts
- 98 Noise & vibration suppression equipment
- 98 Safety equipment & systems

ASSOCIATIONS

DECHEMA E.V., Theodor-Heuss-Allee 25, Frankfurt am Main, Germany 60486 (49-69-75-64-0; FAX: 49-69-75-64-201; www.dechema.de)
 — See our ad on page 22

CLEANING EQUIPMENT & SERVICES

Cleaning equipment, pharmaceutical

PICK HEATERS INC., 730 S. Indiana Ave., P.O. Box 516, West Bend, WI 53095 (262-338-1191; FAX: 262-338-8489; www.pickheaters.com)

Cleaning equipment, steam

PICK HEATERS INC., 730 S. Indiana Ave., P.O. Box 516, West Bend, WI 53095 (262-338-1191; FAX: 262-338-8489; www.pickheaters.com)

Cleaning equipment, tank cleaning

GEA GROUP, 9165 Rumsey Road, Columbia, MD 21045 (800-722-6622; www.gea.com)
 — See our ad on page 23

EQUIPMENT REPAIR & REBUILDING

Pipeline rehabilitation processes

Quickly Prepare, Plug And Repair Leaking Heat Exchanger, Condenser and Boiler Tubes

Pump repair

A-VAC INDUSTRIES, NC., Anaheim, CA

MAINTENANCE TOOLS & EQUIPMENT & REPLACEMENT PARTS

Leak sealing service

CURTISS-WRIGHT EST GROUP, 2701 Township Line Rd., Hatfield, PA 19440 (215-721-1100; FAX: 215-721-1101)

Quickly Prepare, Plug And Repair Leaking Heat Exchanger, Condenser and Boiler Tubes

Plant maintenance services

CURTISS-WRIGHT EST GROUP, 2701 Township Line Rd., Hatfield, PA 19440 (215-721-1100; FAX: 215-721-1101)

Quickly Prepare, Plug And Repair Leaking Heat Exchanger, Condenser and Boiler Tubes

Testing equipment, high pressure

CURTISS-WRIGHT EST GROUP, 2701 Township Line Rd., Hatfield, PA 19440 (215-721-1100; FAX: 215-721-1101)

TLV CORPORATION, 13901 S. Lakes Dr., Charlotte, NC 28273 (704-597-9070; FAX: 704-583-1610; www.tlv.com)

— See our ad on page 65

Tools & equipment, other

BERNDORF BAND GROUP, Leobersdorferstr. 26, Berndorf, Austria 2560 (43-2672-800-0; FAX: 43-2672-84176; www.berndorfband-group.com)

CURTISS-WRIGHT EST GROUP, 2701 Township Line Rd., Hatfield, PA 19440 (215-721-1100; FAX: 215-721-1101)

Tools, hand

EMERSON, 1100 W. Louis Henna Blvd. Building One, Round Rock, TX 78681 - 74 (800-833-8314)

NOISE & VIBRATION SUPPRESSION EQUIPMENT

Analyzers, vibration

EMERSON, 1100 W. Louis Henna Blvd. Building One, Round Rock, TX 78681 - 74 (800-833-8314)

TLV CORPORATION, 13901 S. Lakes Dr., Charlotte, NC 28273 (704-597-9070; FAX: 704-583-1610; www.tlv.com)

— See our ad on page 65

Silencers, exhaust

Durr Universal, Inc., Stoughton, WV
 Valcor Engineering Corp, Springfield, NJ

Silencers, inline

Durr Universal, Inc., Stoughton, WV

Silencers, intake

Durr Universal, Inc., Stoughton, WV

Testing instruments, vibration

TLV CORPORATION, 13901 S. Lakes Dr., Charlotte, NC 28273 (704-597-9070; FAX: 704-583-1610; www.tlv.com)

— See our ad on page 65

SAFETY EQUIPMENT & SYSTEMS

Arresters, flame deflagration or detonation

CASHCO, INC., P.O. Box 6, 607 W. 15th, Ellsworth, KS 67439-0006 (785-472-4461; FAX: 785-472-3539; www.cashco.com)

Det-Tronics, Bloomington, MN

Arresters, flame, tank vent, inline

CASHCO, INC., P.O. Box 6, 607 W. 15th, Ellsworth, KS 67439-0006 (785-472-4461; FAX: 785-472-3539; www.cashco.com)

Det-Tronics, Bloomington, MN

Arresters, surge

CASHCO, INC., P.O. Box 6, 607 W. 15th, Ellsworth, KS 67439-0006 (785-472-4461; FAX: 785-472-3539; www.cashco.com)

Clothing, chemical resistant

Det-Tronics, Bloomington, MN

Containers, safety

Det-Tronics, Bloomington, MN

Emergency shutdown systems

SIEMENS AG, Siemensallee 84, Karlsruhe, Germany D-76187 (+49(0)721/595-0; www.siemens.com)

Explosion isolation

REMBE GMBH SAFETY + CONTROL, Gallbergweg 21, Brilon, Germany 59929 (+49 2961 7405-0; FAX: +49 2961 50714; www.rembe.de)

REMBE INC., 3809 Beam Road Ste K, Charlotte, NC 28217 (704-716-7022; FAX: 704-716-7025)

Explosion vents

REMBE GMBH SAFETY + CONTROL, Gallbergweg 21, Brilon, Germany 59929 (+49 2961 7405-0; FAX: +49 2961 50714; www.rembe.de)

REMBE INC., 3809 Beam Road Ste K, Charlotte, NC 28217 (704-716-7022; FAX: 704-716-7025)

Rupture discs

REMBE GMBH SAFETY + CONTROL, Gallbergweg 21, Brilon, Germany 59929 (+49 2961 7405-0; FAX: +49 2961 50714; www.rembe.de)

REMBE INC., 3809 Beam Road Ste K, Charlotte, NC 28217 (704-716-7022; FAX: 704-716-7025)

ZOOK ENTERPRISES, 16809 Park Circle Drive, Chagrin Falls, OH 44023 (440-543-1010)

Showers, emergency

HEMCO Corporation, Independence, Missouri

Sinks, eye or face emergency

HEMCO Corporation, Independence, Missouri

Storage cabinets

BENKO PRODUCTS, INC., 5350 Evergreen Pkwy., Sheffield Village, OH 44054 (440-934-2180; FAX: 440-934-4052; www.benkoproducts.com)

HEMCO Corporation, Independence, Missouri

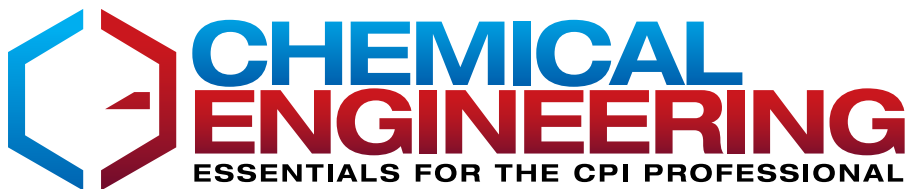

During this worldwide crisis, the chemical process industries (CPI) continue to operate to provide products and services that are part of our critical infrastructure.

As a resource to our CPI community, *Chemical Engineering* has added special coverage around COVID-19, providing easy access to news about what the CPI is doing, calls for assistance, event updates and online resources.

We welcome your input with any news that you would like to share, or requests for ways in which we can help.



Get involved. Visit www.chemengonline.com

8

DESIGN, ENGINEERING, & CONSTRUCTION SERVICES

100 Associations
100 Engineering services
101 Training

ASSOCIATIONS

DECHEMA e.V., Theodor-Heuss-Allee 25, Frankfurt am Main, Germany 60486 (49-69-75-64-0; FAX: 49-69-75-64-201; www.dechema.de)
— See our ad on page 22

ENGINEERING SERVICES

Consultants, corrosion protection

CHEMICAL PROCESS ENGINEERING SERVICES - AFFILIATED ENGINEERS (AEI), Madison, WI

Consultants, engineering

AHED Software, Lorqui, Murcia, Spain
GEA GROUP, 9165 Rumsey Road, Columbia, MD 21045 (800-722-6622; www.gea.com)
— See our ad on page 23

Heat Transfer Research, Inc. (HTRI), Navasota, TX
JENIKE & JOHANSON INC., 400 Business Park Dr., Tyngsboro, MA 01879-1077 (978-649-3300; FAX: 978-649-3399)

Nol-Tec Systems, Inc., Lino Lakes, MN
OILTECH srl, Italy
Wenck Associates, Inc., Golden Valley, MN

Consultants, materials

Wenck Associates, Inc., Golden Valley, MN

Consultants, safety & health

CHEMICAL PROCESS ENGINEERING SERVICES - AFFILIATED ENGINEERS (AEI), Madison, WI
PROCESS ENGINEERING ASSOCIATES, LLC, 700 South Illinois Ave., Suite A-202, Oak Ridge, TN 37830 (865-220-8722; FAX: 865-220-8729; info@processengr.com; www.processengr.com)

Consultants, water treatment

Caloris Engineering, Easton, MD
PROCESS ENGINEERING ASSOCIATES, LLC, 700 South Illinois Ave., Suite A-202, Oak Ridge, TN 37830 (865-220-8722; FAX: 865-220-8729; info@processengr.com; www.processengr.com)

Contract manufacturing services

ENTEX Rust & Mitschke GmbH, Bochum, NRW, Germany

Custom processing

ENTEX Rust & Mitschke GmbH, Bochum, NRW, Germany
IPCO GERMANY GMBH, Salierstr. 35, Fellbach, Germany 70736 (+49 711 5105 0)
Kemperle Industries - Digital Design, New York, NY

Database services

DECHEMA E.V., Theodor-Heuss-Allee 25, Frankfurt am Main, Germany 60486 (49-69-75-64-0; FAX: 49-69-75-64-201; www.dechema.de)
— See our ad at page 22

Engineering, biochemical & biotech

CHEMICAL PROCESS ENGINEERING SERVICES - AFFILIATED ENGINEERS (AEI), Madison, WI

Engineering: construction & field erection

NEUHAUS NEOTEC Maschinen- und Anlagenbau GmbH, Ganderkesee, Germany
THYSSENKRUPP INDUSTRIAL SOLUTIONS AG, thyssenkrupp Allee 1, Essen, Germany 45143 (49-201 8440; info.industrial-solutions@thyssenkrupp.com; www.thyssenkrupp-industrial-solutions.com)
Water Heating Direct, Fort Worth, TX

Engineering: cryogenic equipment

KOCH-GLITSCH, INC., 4111 E. 37th St. N., Wichita, KS 67220 (316-828-5110; FAX: 316-828-7985)
— See our ad inside front cover
LAUDA DR. R. WOBSEER GMBH & CO. KG, Lauda-Koenigshofen, Germany
NEUHAUS NEOTEC Maschinen- und Anlagenbau GmbH, Ganderkesee, Germany

Engineering: facilities planning

THYSSENKRUPP INDUSTRIAL SOLUTIONS AG, thyssenkrupp Allee 1, Essen, Germany 45143 (49-201 8440; info.industrial-solutions@thyssenkrupp.com; www.thyssenkrupp-industrial-solutions.com)
Wenck Associates, Inc., Golden Valley, MN

Engineering: instrumentation & control systems

ABB INC., 3700 West Sam Houston Parkway South, Houston, TX 77042 (1-800-HELP-365; FAX: 440-585-7071; contact.center@us.abb.com; www.abb.com/chemical)
CHEMICAL PROCESS ENGINEERING SERVICES - AFFILIATED ENGINEERS (AEI), Madison, WI
Flottweg SE, Vilsbiburg, Germany
MATHWORKS, 1 Apple Hill Drive, Natick, MA 01760-2098 (508-647-7000; FAX: 508-647-7001; www.mathworks.com)

Nol-Tec Systems, Inc., Lino Lakes, MN
PEPPERL+FUCHS SE, Lilienthalstrasse 200, Mannheim, Germany 68307 (+49-621-776-0; FAX: +49-621-776-1000; www.pepperl-fuchs.com)

SIEMENS AG, Siemensallee 84, Karlsruhe, Germany D-76187 (+49(0)721/595-0; www.siemens.com)
SIEMENS PROCESS INSTRUMENTATION, 2060 Detwiler Road, Suite 111, Harleysville, PA 19438 (800-365-8766; piabu-requestinformation.industry@siemens.com; www.usa.siemens.com/pablog)
SWAGelok CO., 29500 Solon Road, Solon, OH 44139-2764 (440-248-4600; www.swagelok.com)
Yokogawa Corporation of America, Sugar Land, TX

Engineering: modular process systems

EKATO RUEHR- UND MISCHTECHNIK GMBH, Hohe-Flum-Str.37, Schopfheim, Germany D-79650 (+49 7622 290; FAX: + 49 7622 29 213; www.ekato.com)
— See our ad on page 84
ENTEX Rust & Mitschke GmbH, Bochum, NRW, Germany
EPIC Systems Group, Peoria, IL
FLUID LINE PRODUCTS INC., 38273 Western Pkwy., P.O. Box 1000, Willoughby, OH 44096 (440-946-9470; FAX: 440-946-9472; www.fluidline.com)

GEA GROUP, 9165 Rumsey Road, Columbia, MD 21045 (800-722-6622; www.gea.com)
— See our ad on page 23

Koch Modular Process, Paramus, NJ
OILTECH srl, Italy
POPE SCIENTIFIC, INC., P.O. Box 80018, 351 N. Dekora Woods Blvd., Saukville, WI 53080 (262-268-9300; FAX: 262-268-9400; info@popeinc.com; www.popeinc.com)

PROCESS ENGINEERING ASSOCIATES, LLC, 700 South Illinois Ave., Suite A-202, Oak Ridge, TN 37830 (865-220-8722; FAX: 865-220-8729; info@processengr.com; www.processengr.com)

Engineering: packaged pilot plants

Biazzi SA, Chailly/Montreux, Switzerland
EPIC Systems Group, Peoria, IL
POPE SCIENTIFIC, INC., P.O. Box 80018, 351 N. Dekora Woods Blvd., Saukville, WI 53080 (262-268-9300; FAX: 262-268-9400; info@popeinc.com; www.popeinc.com)
PROCESS ENGINEERING ASSOCIATES, LLC, 700 South Illinois Ave., Suite A-202, Oak Ridge, TN 37830 (865-220-8722; FAX: 865-220-8729; info@processengr.com; www.processengr.com)

Engineering: pilot plants

ENTEX Rust & Mitschke GmbH, Bochum, NRW, Germany
EPIC Systems Group, Peoria, IL
GEA GROUP, 9165 Rumsey Road, Columbia, MD 21045 (800-722-6622; www.gea.com)
— See our ad on page 23

HTE GMBH - THE HIGH THROUGHPUT EXPERIMENTATION COMPANY, Kurpfalzring 104, Heidelberg, Germany D-69123 (+49 (0) 62 21.74 97 - 0; FAX: +49 (0) 62 21.74 97 - 137; www.hte-company.de)

POPE SCIENTIFIC, INC., P.O. Box 80018, 351 N. Dekora Woods Blvd., Saukville, WI 53080 (262-268-9300; FAX: 262-268-9400; info@popeinc.com; www.popeinc.com)

PROCESS ENGINEERING ASSOCIATES, LLC, 700 South Illinois Ave., Suite A-202, Oak Ridge, TN 37830 (865-220-8722; FAX: 865-220-8729; info@processengr.com; www.processengr.com)

Engineering: plant design

Biazzi SA, Chailly/Montreux, Switzerland
EPIC Systems Group, Peoria, IL
OILTECH srl, Italy
PROCESS ENGINEERING ASSOCIATES, LLC, 700 South Illinois Ave., Suite A-202, Oak Ridge, TN 37830 (865-220-8722; FAX: 865-220-8729; info@processengr.com; www.processengr.com)

THYSSENKRUPP INDUSTRIAL SOLUTIONS AG, thyssenkrupp Allee 1, Essen, Germany 45143 (49-201 8440; info.industrial-solutions@thyssenkrupp.com; www.thyssenkrupp-industrial-solutions.com)

Wenck Associates, Inc., Golden Valley, MN
YSTRAL GMBH, Wettelbrunner Str. 7, Ballrechten-Dottingen, Germany 79282 (+49 7634 5603 900; www.ystral.com)

Engineering: plant modernization

EPIC Systems Group, Peoria, IL

PROCESS ENGINEERING ASSOCIATES, LLC, 700 South Illinois Ave., Suite A-202, Oak Ridge, TN 37830 (865-220-8722; FAX: 865-220-8729; info@processengr.com; www.processengr.com)

Engineering: pollution & environmental services

DURR SYSTEMS, INC., 26801 Northwestern Highway, Southfield, MI 48033 (248-450-2000) Environmental C&C, St. Charles, IL

GEA GROUP, 9165 Rumsey Road, Columbia, MD 21045 (800-722-6622; www.gea.com)

— See our ad on page 23

Nol-Tec Systems, Inc., Lino Lakes, MN

PROCESS ENGINEERING ASSOCIATES, LLC, 700 South Illinois Ave., Suite A-202, Oak Ridge, TN 37830 (865-220-8722; FAX: 865-220-8729; info@processengr.com; www.processengr.com)

Engineering: process design

Biazzi SA, Chailly/Montreux, Switzerland
CHEMICAL PROCESS ENGINEERING SERVICES - AFFILIATED ENGINEERS (AEI), Madison, WI

EKATO RUEHR- UND MISCHTECHNIK GMBH, Hoheflum-Str.37, Schopfheim, Germany D-79650 (+49 7622 290; FAX: +49 7622 29 213; www.ekato.com)

— See our ad on page 84

FLUID LINE PRODUCTS INC., 38273 Western Pkwy., P.O. Box 1000, Willoughby, OH 44096 (440-946-9470; FAX: 440-946-9472; www.fluidline.com)

GEA GROUP, 9165 Rumsey Road, Columbia, MD 21045 (800-722-6622; www.gea.com)

— See our ad on page 23

Kemperle Industries - Digital Design, New York, NY
MATHWORKS, 1 Apple Hill Drive, Natick, MA 01760-2098 (508-647-7000; FAX: 508-647-7001; www.mathworks.com)

Nol-Tec Systems, Inc., Lino Lakes, MN

PROCESS ENGINEERING ASSOCIATES, LLC, 700 South Illinois Ave., Suite A-202, Oak Ridge, TN 37830 (865-220-8722; FAX: 865-220-8729; info@processengr.com; www.processengr.com)

Engineering: process modeling

EKATO RUEHR- UND MISCHTECHNIK GMBH, Hoheflum-Str.37, Schopfheim, Germany D-79650 (+49 7622 290; FAX: +49 7622 29 213; www.ekato.com)

— See our ad on page 84

FLUID LINE PRODUCTS INC., 38273 Western Pkwy., P.O. Box 1000, Willoughby, OH 44096 (440-946-9470; FAX: 440-946-9472; www.fluidline.com)

Heat Transfer Research, Inc. (HTRI), Navasota, TX
Kemperle Industries - Digital Design, New York, NY
MATHWORKS, 1 Apple Hill Drive, Natick, MA 01760-2098 (508-647-7000; FAX: 508-647-7001; www.mathworks.com)

OILTECH srl, Italy

PROCESS ENGINEERING ASSOCIATES, LLC, 700 South Illinois Ave., Suite A-202, Oak Ridge, TN 37830 (865-220-8722; FAX: 865-220-8729; info@processengr.com; www.processengr.com)

Engineering: procurement

THYSSENKRUPP INDUSTRIAL SOLUTIONS AG, thyssenkrupp Allee 1, Essen, Germany 45143 (49-201 8440; info.industrial-solutions@thyssenkrupp.com; www.thyssenkrupp-industrial-solutions.com)

Engineering: project management

EnsureworX, Canada

THYSSENKRUPP INDUSTRIAL SOLUTIONS AG, thyssenkrupp Allee 1, Essen, Germany 45143 (49-201 8440; info.industrial-solutions@thyssenkrupp.com; www.thyssenkrupp-industrial-solutions.com)

Wenck Associates, Inc., Golden Valley, MN

Engineering: research

HTE GMBH - THE HIGH THROUGHPUT EXPERIMENTATION COMPANY, Kurpfalzring 104, Heidelberg, Germany D-69123 (+49 (0) 62 21.74 97 - 0; FAX: +49 (0) 62 21.74 97 - 137; www.hte-company.de)

PROCESS ENGINEERING ASSOCIATES, LLC, 700 South Illinois Ave., Suite A-202, Oak Ridge, TN 37830 (865-220-8722; FAX: 865-220-8729; info@processengr.com; www.processengr.com)

Equipment testing

Heat Transfer Research, Inc. (HTRI), Navasota, TX
JENIKE & JOHANSON INC., 400 Business Park Dr., Tyngsboro, MA 01879-1077 (978-649-3300; FAX: 978-649-3399)

KOCH-GLITSCH, INC., 4111 E. 37th St. N., Wichita, KS 67220 (316-828-5110; FAX: 316-828-7985)

— See our ad inside front cover

SARTORIUS - CHEMICAL & CONSUMER CARE, Otto-Brenner-Straße 20, Goettingen, Germany 37079 (+49-0)551 3084756; www.sartorius.com/chemicals)

Equipment, used: procurement & supply

INDECK POWER EQUIPMENT CO., 1111 Willis Ave. (CE), Wheeling, IL 60090 (847-541-8300; FAX: 847-541-9984; www.indeck.com)

— See our ad on page 15

Inspection

EnsureworX, Canada

Pilot plant services

BUSS-SMS-CANZLER GMBH, Kaiserstr. 13-15, Butzbach, Germany 35510 (49-6033-85-0; FAX: 49-6033-85-249)

GEA GROUP, 9165 Rumsey Road, Columbia, MD 21045 (800-722-6622; www.gea.com)

— See our ad on page 23
HTE GMBH - THE HIGH THROUGHPUT EXPERIMENTATION COMPANY, Kurpfalzring 104, Heidelberg, Germany D-69123 (+49 (0) 62 21.74 97 - 0; FAX: +49 (0) 62 21.74 97 - 137; www.hte-company.de)

POPE SCIENTIFIC, INC., P.O. Box 80018, 351 N. Dekora Woods Blvd., Saukville, WI 53080 (262-268-9300; FAX: 262-268-9400; info@popeinc.com; www.popeinc.com)

Plant documentation services

PROCESS ENGINEERING ASSOCIATES, LLC, 700 South Illinois Ave., Suite A-202, Oak Ridge, TN 37830 (865-220-8722; FAX: 865-220-8729; info@processengr.com; www.processengr.com)

Process safety management services

Method Process Safety Training, HAZOP, LOPA and Consultancy, Luton, United Kingdom

PROCESS ENGINEERING ASSOCIATES, LLC, 700 South Illinois Ave., Suite A-202, Oak Ridge, TN 37830 (865-220-8722; FAX: 865-220-8729; info@processengr.com; www.processengr.com)

Risk analysis

Method Process Safety Training, HAZOP, LOPA and Consultancy, Luton, United Kingdom

PROCESS ENGINEERING ASSOCIATES, LLC, 700 South Illinois Ave., Suite A-202, Oak Ridge, TN 37830 (865-220-8722; FAX: 865-220-8729; info@processengr.com; www.processengr.com)

REMBE GMBH SAFETY + CONTROL, Gallbergweg 21, Brilon, Germany 59929 (+49 2961 7405-0; FAX: +49 2961 50714; www.rembe.de)

Technology licensing

HTE GMBH - THE HIGH THROUGHPUT EXPERIMENTATION COMPANY, Kurpfalzring 104, Heidelberg, Germany D-69123 (+49 (0) 62 21.74 97 - 0; FAX: +49 (0) 62 21.74 97 - 137; www.hte-company.de)

TRAINING

Training personnel, maintenance

BERNDORF BAND GROUP, Leobersdorferstr. 26, Berndorf, Austria 2560 (43-2672-800-0; FAX: 43-2672-84176; www.berndorfband-group.com)

Method Process Safety Training, HAZOP, LOPA and Consultancy, Luton, United Kingdom

SIEMENS PROCESS INSTRUMENTATION, 2060 Detwiler Road, Suite 111, Harleysville, PA 19438 (800-365-8766; piabu-request@information.industry@siemens.com; www.usa.siemens.com/pablog)

SWAGelok CO., 29500 Solon Road, Solon, OH 44139-2764 (440-248-4600; www.swagelok.com)

Training personnel, safety & health

Method Process Safety Training, HAZOP, LOPA and Consultancy, Luton, United Kingdom

PEPPERL+FUCHS SE, Lilienthalstrasse 200, Mannheim, Germany 68307 (+49-621-776-0; FAX: +49-621-776-1000; www.pepperl-fuchs.com)

PROCESS ENGINEERING ASSOCIATES, LLC, 700 South Illinois Ave., Suite A-202, Oak Ridge, TN 37830 (865-220-8722; FAX: 865-220-8729; info@processengr.com; www.processengr.com)

Training systems, plant operators

Method Competency Register, Luton, United Kingdom
Method Process Safety Training, HAZOP, LOPA and Consultancy, Luton, United Kingdom



CHEMICAL

ENGINEERING'S

PREMIUM PRODUCT

SHOWCASE FOR THE

LATEST PRODUCTS

AND TECHNOLOGIES

IN THE CHEMICAL

PROCESSING

INDUSTRIES.

TO SUBSCRIBE

TO THE

E-LETTER,

PLEASE VISIT:

WWW.CHEMENGONLINE.COM
/ELETTER-SIGNUP

9

INFORMATION TECHNOLOGIES

- 102 Associations
- 102 Computer hardware
- 102 Computer software
- 103 Computers for design & engineering

ASSOCIATIONS

DECHEMA E.V., Theodor-Heuss-Allee 25, Frankfurt am Main, Germany 60486 (49-69-75-64-0; FAX: 49-69-75-64-201; www.dechema.de)
 — See our ad on page 22

COMPUTER HARDWARE

Computers, monitors & displays

Ameritechnology, Hackensack, NJ

Computers, personal

Ameritechnology, Hackensack, NJ

Computers, printers & plotters

Ameritechnology, Hackensack, NJ

Input & output equipment, data processing

PEPPERL+FUCHS SE, Lilienthalstrasse 200, Mannheim, Germany 68307 (+49-621-776-0; FAX: +49-621-776-1000; www.pepperl-fuchs.com)

Manufacturing execution systems

ABB INC., 3700 West Sam Houston Parkway South, Houston, TX 77042 (1-800-HELP-365; FAX: 440-585-7071; contact.center@us.abb.com; www.abb.com/chemical)

Simulators

ABB INC., 3700 West Sam Houston Parkway South, Houston, TX 77042 (1-800-HELP-365; FAX: 440-585-7071; contact.center@us.abb.com; www.abb.com/chemical)

COMPUTER SOFTWARE

Advanced process control

ABB INC., 3700 West Sam Houston Parkway South, Houston, TX 77042 (1-800-HELP-365; FAX: 440-585-7071; contact.center@us.abb.com; www.abb.com/chemical)

SIEMENS AG, Siemensallee 84, Karlsruhe, Germany D-76187 (+49(0)721/595-0; www.siemens.com)
 Yokogawa Corporation of America, Sugar Land, TX

Alarm Management

SIEMENS AG, Siemensallee 84, Karlsruhe, Germany D-76187 (+49(0)721/595-0; www.siemens.com)
 Yokogawa Corporation of America, Sugar Land, TX

Asset management

SIEMENS AG, Siemensallee 84, Karlsruhe, Germany D-76187 (+49(0)721/595-0; www.siemens.com)
 Yokogawa Corporation of America, Sugar Land, TX

Batch control

ABB INC., 3700 West Sam Houston Parkway South, Houston, TX 77042 (1-800-HELP-365; FAX: 440-585-7071; contact.center@us.abb.com; www.abb.com/chemical)

ASPEN TECHNOLOGY, INC., 20 Crosby Dr., Bedford, MA 01730 (781-221-6410; FAX: 781-221-6410; www.aspentech.com)

SIEMENS AG, Siemensallee 84, Karlsruhe, Germany D-76187 (+49(0)721/595-0; www.siemens.com)
 Yokogawa Corporation of America, Sugar Land, TX

Chemical equipment design

AHED Software, Lorqui, Murcia, Spain
CHEMSTATIONS, INC., 11000 Richmond DR, Suite 580, Houston, TX 77042 (713-978-7700; FAX: 713-978-7727; www.chemstations.com)
 — See our ad on page 9

Heat Transfer Research, Inc. (HTRI), Navasota, TX

Chemical plant design & maintenance

ASPEN TECHNOLOGY, INC., 20 Crosby Dr., Bedford, MA 01730 (781-221-6410; FAX: 781-221-6410; www.aspentech.com)

BENTLEY SYSTEMS INC., 685 Stockton Drive, Exton, PA 19341 (610-321-6470)
CHEMSTATIONS, INC., 11000 Richmond DR, Suite 580, Houston, TX 77042 (713-978-7700; FAX: 713-978-7727; www.chemstations.com)
 — See our ad on page 9

Chemical process design

CHEMSTATIONS, INC., 11000 Richmond DR, Suite 580, Houston, TX 77042 (713-978-7700; FAX: 713-978-7727; www.chemstations.com)
 — See our ad on page 9

Data acquisition & process control

ABB INC., 3700 West Sam Houston Parkway South, Houston, TX 77042 (1-800-HELP-365; FAX: 440-585-7071; contact.center@us.abb.com; www.abb.com/chemical)

CHEMSTATIONS, INC., 11000 Richmond DR, Suite 580, Houston, TX 77042 (713-978-7700; FAX: 713-978-7727; www.chemstations.com)
 — See our ad on page 9

SEEQ CORPORATION, 1301 2nd Avenue, Ste. 2850, Seattle, WA 98101 (206-801-9339)
VEGA AMERICAS, INC., 4170 Rosslyn Drive, Cincinnati, OH 45209 (513-272-0131; FAX: 513-272-0133; www.vega.com)

VEGA GRIESHABER KG, Am Hohenstein 113, Schiltach, Germany, Germany 77761 (+49 7836 50-0; www.vega.com)

Data visualization

Antea North America, Houston, TX
BENTLEY SYSTEMS INC., 685 Stockton Drive, Exton, PA 19341 (610-321-6470)
 EnsureworX, Canada

SEEQ CORPORATION, 1301 2nd Avenue, Ste. 2850, Seattle, WA 98101 (206-801-9339)
VEGA AMERICAS, INC., 4170 Rosslyn Drive, Cincinnati, OH 45209 (513-272-0131; FAX: 513-272-0133; www.vega.com)
VEGA GRIESHABER KG, Am Hohenstein 113, Schiltach, Germany, Germany 77761 (+49 7836 50-0; www.vega.com)

Failure analysis

BENTLEY SYSTEMS INC., 685 Stockton Drive, Exton, PA 19341 (610-321-6470)

Heat-exchange modeling

AHED Software, Lorqui, Murcia, Spain
ASPEN TECHNOLOGY, INC., 20 Crosby Dr., Bedford, MA 01730 (781-221-6410; FAX: 781-221-6410; www.aspentech.com)
CHEMSTATIONS, INC., 11000 Richmond DR, Suite 580, Houston, TX 77042 (713-978-7700; FAX: 713-978-7727; www.chemstations.com)
 — See our ad on page 9

Heat Transfer Research, Inc. (HTRI), Navasota, TX

Information management

ABB INC., 3700 West Sam Houston Parkway South, Houston, TX 77042 (1-800-HELP-365; FAX: 440-585-7071; contact.center@us.abb.com; www.abb.com/chemical)
 Method Competency Register, Luton, United Kingdom

Information Technology

Ameritechnology, Hackensack, NJ
 EnsureworX, Canada

Laboratory information management

HTE GMBH - THE HIGH THROUGHPUT EXPERIMENTATION COMPANY, Kurpfalzring 104, Heidelberg, Germany D-69123 (+49 (0) 62 21.74 97 - 0; FAX: +49 (0) 62 21.74 97 - 137; www.hte-company.de)

Manufacturing execution systems

ABB INC., 3700 West Sam Houston Parkway South, Houston, TX 77042 (1-800-HELP-365; FAX: 440-585-7071; contact.center@us.abb.com; www.abb.com/chemical)

ASPEN TECHNOLOGY, INC., 20 Crosby Dr., Bedford, MA 01730 (781-221-6410; FAX: 781-221-6410; www.aspentech.com)

Mathematics & statistics

MATHWORKS, 1 Apple Hill Drive, Natick, MA 01760-2098 (508-647-7000; FAX: 508-647-7001; www.mathworks.com)

Mechanical integrity

Antea North America, Houston, TX

Physical properties

AHED Software, Lorqui, Murcia, Spain
CHEMSTATIONS, INC., 11000 Richmond DR, Suite 580, Houston, TX 77042 (713-978-7700; FAX: 713-978-7727; www.chemstations.com)
 — See our ad on page 9

Plant optimization

ABB INC., 3700 West Sam Houston Parkway South, Houston, TX 77042 (1-800-HELP-365; FAX: 440-585-7071; contact.center@us.abb.com; www.abb.com/chemical)
 Antea North America, Houston, TX

PRODUCT DIRECTORY

Information Technologies

BENTLEY SYSTEMS INC., 685 Stockton Drive, Exton, PA 19341 (610-321-6470)

CHEMSTATIONS, INC., 11000 Richmond DR, Suite 580, Houston, TX 77042 (713-978-7700; FAX: 713-978-7727; www.chemstations.com)

— See our ad on page 9

SEEQ CORPORATION, 1301 2nd Avenue, Ste. 2850, Seattle, WA 98101 (206-801-9339)

SIEMENS AG, Siemensallee 84, Karlsruhe, Germany D-76187 (+49(0)721/595-0; www.siemens.com)

Process control

SIEMENS AG, Siemensallee 84, Karlsruhe, Germany D-76187 (+49(0)721/595-0; www.siemens.com)

Process optimization

CHEMSTATIONS, INC., 11000 Richmond DR, Suite 580, Houston, TX 77042 (713-978-7700; FAX: 713-978-7727; www.chemstations.com)

— See our ad on page 9

SEEQ CORPORATION, 1301 2nd Avenue, Ste. 2850, Seattle, WA 98101 (206-801-9339)

SIEMENS AG, Siemensallee 84, Karlsruhe, Germany D-76187 (+49(0)721/595-0; www.siemens.com)

TLV CORPORATION, 13901 S. Lakes Dr., Charlotte, NC 28273 (704-597-9070; FAX: 704-583-1610; www.tlv.com)

— See our ad on page 65

Process safety management

ABB INC., 3700 West Sam Houston Parkway South, Houston, TX 77042 (1-800-HELP-365; FAX: 440-585-7071; contact.center@us.abb.com; www.abb.com/chemical)

Antea North America, Houston, TX

SIEMENS AG, Siemensallee 84, Karlsruhe, Germany D-76187 (+49(0)721/595-0; www.siemens.com)

Process simulation

ABB INC., 3700 West Sam Houston Parkway South, Houston, TX 77042 (1-800-HELP-365; FAX: 440-585-7071; contact.center@us.abb.com; www.abb.com/chemical)

ASPEN TECHNOLOGY, INC., 20 Crosby Dr., Bedford, MA 01730 (781-221-6410; FAX: 781-221-6410; www.aspentech.com)

CHEMSTATIONS, INC., 11000 Richmond DR, Suite 580, Houston, TX 77042 (713-978-7700; FAX: 713-978-7727; www.chemstations.com)

— See our ad on page 9

Production scheduling

ABB INC., 3700 West Sam Houston Parkway South, Houston, TX 77042 (1-800-HELP-365; FAX: 440-585-7071; contact.center@us.abb.com; www.abb.com/chemical)

ASPEN TECHNOLOGY, INC., 20 Crosby Dr., Bedford, MA 01730 (781-221-6410; FAX: 781-221-6410; www.aspentech.com)

Regulatory compliance

BENTLEY SYSTEMS INC., 685 Stockton Drive, Exton, PA 19341 (610-321-6470)

Method Competency Register, Luton, United Kingdom

Software development

ABB INC., 3700 West Sam Houston Parkway South, Houston, TX 77042 (1-800-HELP-365; FAX: 440-585-7071; contact.center@us.abb.com; www.abb.com/chemical)

AHED Software, Lorqui, Murcia, Spain
EnsureworX, Canada

Software, other

ABB INC., 3700 West Sam Houston Parkway South, Houston, TX 77042 (1-800-HELP-365; FAX: 440-585-7071; contact.center@us.abb.com; www.abb.com/chemical)

Ameritechnology, Hackensack, NJ

Antea North America, Houston, TX

APPLIED FLOW TECHNOLOGY (AFT), 2955 Professional Place, Suite 301, Colorado Springs, CO 80904 (719-686-1000; www.aft.com)

CHEMSTATIONS, INC., 11000 Richmond DR, Suite 580, Houston, TX 77042 (713-978-7700; FAX: 713-978-7727; www.chemstations.com)

— See our ad on page 9

KOCH-GLITSCH, INC., 4111 E. 37th St. N., Wichita, KS 67220 (316-828-5110; FAX: 316-828-7985)

— See our ad inside front cover

SEEQ CORPORATION, 1301 2nd Avenue, Ste. 2850, Seattle, WA 98101 (206-801-9339)

TLV CORPORATION, 13901 S. Lakes Dr., Charlotte, NC 28273 (704-597-9070; FAX: 704-583-1610; www.tlv.com)

— See our ad on page 65

COMPUTERS FOR DESIGN & ENGINEERING

Process simulation systems

ABB INC., 3700 West Sam Houston Parkway South, Houston, TX 77042 (1-800-HELP-365; FAX: 440-585-7071; contact.center@us.abb.com; www.abb.com/chemical)

MATHWORKS, 1 Apple Hill Drive, Natick, MA 01760-2098 (508-647-7000; FAX: 508-647-7001; www.mathworks.com)

CE Voices



INSIGHTFUL CONVERSATIONS BROUGHT TO YOU BY

CHEMICAL ENGINEERING

ESSENTIALS FOR THE CPI PROFESSIONAL

Chemical Engineering is excited to announce the launch of our new bi-weekly video series, CE Voices. This series consists of editorial interviews with executives and industry leaders where timely conversations take place on a variety of topics impacting the CPI landscape as a whole, providing much needed updates and analysis on this critical industry.

Join the conversation at www.chemengonline.com/ce-voices

RECEIVE FULL ACCESS

to ALL of Chemical Engineering's Facts at Your Fingertips articles in one convenient location.

EACH INFORMATION PACKED PDF ARTICLE

includes graphs, charts, tables, equations and columns on the full chemical engineering processes you deal with on a daily basis. This is the tool you will come to rely on, referring back to the information again and again with just the click of a mouse.

Facts at Your Fingertips Topics Include:

- Conservation Economics: Carbon Pricing Impacts
- Distillation Tray Design
- Burner Operating Characteristics
- Measurement Guide for Replacement Seals
- Steam Tracer Lines and Traps
- Positive Displacement Pumps
- Low-Pressure Measurement for Control Valves
- Creating Installed Gain Graphs
- Aboveground and Underground Storage Tanks
- Chemical Resistance of Thermoplastics
- Heat Transfer: System Design II
- Adsorption
- Flowmeter Selection
- Specialty Metals
- Plus much, much more...

Receive full access today by visiting
www.chemengonline.com/magazine/facts-at-your-fingertips

10

ENVIRONMENTAL SERVICES

- 105** Associations
- 105** Air pollution control equipment & systems
- 105** Environmental services
- 106** Waste handling equipment & systems

ASSOCIATIONS

DECHEMA E.V., Theodor-Heuss-Allee 25, Frankfurt am Main, Germany 60486 (49-69-75-64-0; FAX: 49-69-75-64-201; www.dechema.de)
— See our ad on page 22

AIR POLLUTION CONTROL EQUIPMENT & SYSTEMS

Adsorption systems, carbon

Bionomic Industries Inc., Mahwah, NJ
CR CLEAN AIR, Six Campus Drive, Parsippany, NJ 07054 (973-947-8787; FAX: 908-232-2146; info@crcleanair.com; www.crcleanair.com)
DÜRR SYSTEMS, INC., 830 Prosper Street, WI 54115 (920-336-5715; www.durr-megtec.com)
 — See our ad on page 43
 Environmental C&C, St. Charles, IL
MACROTEK INC., 421 Bentley St. Unit 1, Markham, ON, Canada L3R 9T2 (905-415-1799)

Afferburners

Catalytic Products International Inc., Lake Zurich, IL

Air pollution abatement systems

BELTRAN TECHNOLOGIES, INC., 1133 East 35 Street, Brooklyn, NY 11210 (718-338-3311; FAX: 718-253-9028; info@beltrantechnologies.com; www.beltrantechnologies.com)
 Bionomic Industries Inc., Mahwah, NJ
 Catalytic Products International Inc., Lake Zurich, IL
CR CLEAN AIR, Six Campus Drive, Parsippany, NJ 07054 (973-947-8787; FAX: 908-232-2146; info@crcleanair.com; www.crcleanair.com)
DÜRR SYSTEMS, INC., 26801 Northwestern Highway, Southfield, MI 48033 (248-450-2000)
DÜRR SYSTEMS, INC., 830 Prosper Street, WI 54115 (920-336-5715; www.durr-megtec.com)
 — See our ad on page 43
 Environmental C&C, St. Charles, IL
HONEYWELL, 101 Columbia Rd., Morristown, NJ 07962 (973-455-2000; FAX: 973-455-5722)
 Nol-Tec Systems, Inc., Lino Lakes, MN
 Strobic Air Technologies, Lansdale, PA

Combustors, catalytic

Catalytic Products International Inc., Lake Zurich, IL

Combustors, other

Catalytic Products International Inc., Lake Zurich, IL

Flares, stack & accessories

JOHN ZINK HAMWORTHY COMBUSTION, 11920 East Apache Street, Tulsa, OK 74116 (918-234-2800; FAX: 918-234-1800)
 Zeeco, Inc., Broken Arrow, OK

Hydrogen sulfide removal systems

Bionomic Industries Inc., Mahwah, NJ

DÜRR SYSTEMS, INC., 830 Prosper Street, WI 54115 (920-336-5715; www.durr-megtec.com)
 — See our ad on page 43
MACROTEK INC., 421 Bentley St. Unit 1, Markham, ON, Canada L3R 9T2 (905-415-1799)

NOx control systems

BELTRAN TECHNOLOGIES, INC., 1133 East 35 Street, Brooklyn, NY 11210 (718-338-3311; FAX: 718-253-9028; info@beltrantechnologies.com; www.beltrantechnologies.com)
 Bionomic Industries Inc., Mahwah, NJ
DÜRR SYSTEMS, INC., 26801 Northwestern Highway, Southfield, MI 48033 (248-450-2000)
GEA GROUP, 9165 Rumsey Road, Columbia, MD 21045 (800-722-6622; www.gea.com)
 — See our ad on page 23
JOHN ZINK HAMWORTHY COMBUSTION, 11920 East Apache Street, Tulsa, OK 74116 (918-234-2800; FAX: 918-234-1800)
SICK, INC., 6900 West 110th Street, Bloomington, MN 55438 (800-325-7425; www.sick.com)

Odor-control systems

Bionomic Industries Inc., Mahwah, NJ
 Catalytic Products International Inc., Lake Zurich, IL
CR CLEAN AIR, Six Campus Drive, Parsippany, NJ 07054 (973-947-8787; FAX: 908-232-2146; info@crcleanair.com; www.crcleanair.com)
DÜRR SYSTEMS, INC., 26801 Northwestern Highway, Southfield, MI 48033 (248-450-2000)
DÜRR SYSTEMS, INC., 830 Prosper Street, WI 54115 (920-336-5715; www.durr-megtec.com)
 — See our ad on page 43
 Environmental C&C, St. Charles, IL
MACROTEK INC., 421 Bentley St. Unit 1, Markham, ON, Canada L3R 9T2 (905-415-1799)
 Strobic Air Technologies, Lansdale, PA

Particulate removal systems

BELTRAN TECHNOLOGIES, INC., 1133 East 35 Street, Brooklyn, NY 11210 (718-338-3311; FAX: 718-253-9028; info@beltrantechnologies.com; www.beltrantechnologies.com)
DÜRR SYSTEMS, INC., 830 Prosper Street, WI 54115 (920-336-5715; www.durr-megtec.com)
 — See our ad on page 43
MACROTEK INC., 421 Bentley St. Unit 1, Markham, ON, Canada L3R 9T2 (905-415-1799)

Sulfur Recovery

JOHN ZINK HAMWORTHY COMBUSTION, 11920 East Apache Street, Tulsa, OK 74116 (918-234-2800; FAX: 918-234-1800)
MACROTEK INC., 421 Bentley St. Unit 1, Markham, ON, Canada L3R 9T2 (905-415-1799)

Vapor recovery systems

CR CLEAN AIR, Six Campus Drive, Parsippany, NJ 07054 (973-947-8787; FAX: 908-232-2146; info@crcleanair.com; www.crcleanair.com)
DÜRR SYSTEMS, INC., 26801 Northwestern Highway, Southfield, MI 48033 (248-450-2000)
 Environmental C&C, St. Charles, IL

JOHN ZINK HAMWORTHY COMBUSTION, 11920 East Apache Street, Tulsa, OK 74116 (918-234-2800; FAX: 918-234-1800)
XCHANGER, INC., 1401 S. 7th St., Hopkins, MN 55343 (952-933-2559; www.xchanger.com)
 Zeeco, Inc., Broken Arrow, OK

ENVIRONMENTAL SERVICES

Air pollution control

BELTRAN TECHNOLOGIES, INC., 1133 East 35 Street, Brooklyn, NY 11210 (718-338-3311; FAX: 718-253-9028; info@beltrantechnologies.com; www.beltrantechnologies.com)
CR CLEAN AIR, Six Campus Drive, Parsippany, NJ 07054 (973-947-8787; FAX: 908-232-2146; info@crcleanair.com; www.crcleanair.com)
DÜRR SYSTEMS, INC., 26801 Northwestern Highway, Southfield, MI 48033 (248-450-2000)
GEA GROUP, 9165 Rumsey Road, Columbia, MD 21045 (800-722-6622; www.gea.com)
 — See our ad on page 23
JOHN ZINK HAMWORTHY COMBUSTION, 11920 East Apache Street, Tulsa, OK 74116 (918-234-2800; FAX: 918-234-1800)
 Strobic Air Technologies, Lansdale, PA

Environmental consulting

DÜRR SYSTEMS, INC., 26801 Northwestern Highway, Southfield, MI 48033 (248-450-2000)
GEA GROUP, 9165 Rumsey Road, Columbia, MD 21045 (800-722-6622; www.gea.com)
 — See our ad on page 23

Groundwater remediation

GEA GROUP, 9165 Rumsey Road, Columbia, MD 21045 (800-722-6622; www.gea.com)
 — See our ad on page 23

Indoor-air-quality services

Strobic Air Technologies, Lansdale, PA

Sludge handling

Komline-Sanderson Corp., 12 Holland Ave., Peapack, NJ 07977 (908-234-1000; FAX: 908-234-9487)
 — See our ad on page 67

Soil remediation

Komline-Sanderson Corp., 12 Holland Ave., Peapack, NJ 07977 (908-234-1000; FAX: 908-234-9487)
 — See our ad on page 67

VOC control

DÜRR SYSTEMS, INC., 26801 Northwestern Highway, Southfield, MI 48033 (248-450-2000)

WASTE HANDLING EQUIPMENT & SYSTEMS

Incinerators

Waste-to-Energy, Salt Lake City, UT
Zeeco, Inc., Broken Arrow, OK

Incinerators, gas & liquid

Zeeco, Inc., Broken Arrow, OK

Oxidizers, catalytic

JOHN ZINK HAMWORTHY COMBUSTION, 11920 East Apache Street, Tulsa, OK 74116 (918-234-2800; FAX: 918-234-1800)

Oxidizers, thermal

CAST-X Circulation Heaters, Batavia, IL
DURR SYSTEMS, INC., 26801 Northwestern Highway, Southfield, MI 48033 (248-450-2000)

JOHN ZINK HAMWORTHY COMBUSTION, 11920 East Apache Street, Tulsa, OK 74116 (918-234-2800; FAX: 918-234-1800)

Zeeco, Inc., Broken Arrow, OK

WATER POLLUTION CONTROL EQUIPMENT & SYSTEMS

Bio-oxidation units

HONEYWELL, 101 Columbia Rd., Morristown, NJ 07962 (973-455-2000; FAX: 973-455-5722)

Filters, bio-oxidation

HONEYWELL, 101 Columbia Rd., Morristown, NJ 07962 (973-455-2000; FAX: 973-455-5722)

Separators, oil-water

KOCH-GLITSCH, INC., 4111 E. 37th St. N., Wichita, KS 67220 (316-828-5110; FAX: 316-828-7985)
— See our ad inside front cover

Sludge dewaterers

ANDRITZ SEPARATION, ANDRITZ AG, Stattegger Strasse 18, Graz, Austria 8045 (+43 050 8050; separation@andritz.com; www.andritz.com/separation)

GEA GROUP, 9165 Rumsey Road, Columbia, MD 21045 (800-722-6622; www.gea.com)
— See our ad on page 23

HAPMAN, 6002 East N Avenue, Kalamazoo, MI 49048 (269-343-1675; FAX: 269-349-2477; sales@hapman.com; www.hapman.com)

Komline-Sanderson Corp., 12 Holland Ave., Peapack, NJ 07977 (908-234-1000; FAX: 908-234-9487)
— See our ad on page 67

Sludge dryers

ANDRITZ SEPARATION, ANDRITZ AG, Stattegger Strasse 18, Graz, Austria 8045 (+43 050 8050; separation@andritz.com; www.andritz.com/separation)

BUSS-SMS-CANZLER GMBH, Kaiserstr. 13-15, Butzbach, Germany 35510 (49-6033-85-0; FAX: 49-6033-85-249)

Komline-Sanderson Corp., 12 Holland Ave., Peapack, NJ 07977 (908-234-1000; FAX: 908-234-9487)
— See our ad on page 67

Tanks, settling

ROSS MIXERS, 710 Old Willets Path, P.O. Box 12308, Hauppauge, NY 11788-0615 (631-234-0500; FAX: 631-234-0691; www.mixers.com)

Waste-recovery treating systems

ANDRITZ SEPARATION, ANDRITZ AG, Stattegger Strasse 18, Graz, Austria 8045 (+43 050 8050; separation@andritz.com; www.andritz.com/separation)



CHEMICAL ENGINEERING
ESSENTIALS FOR THE CPI PROFESSIONAL

February 2015
www.chemengonline.com

Heat Exchangers:
Two-Part Feature Report
Advances
in 3-D Printing
Focus on Industrial
Housekeeping

Facts at Your Fingertips:
Dimensionless Numbers
Values for
Extreme Service

Fundamentals of
High-Shear Dispersers
Page 40

Written for engineers, by engineers

More and more, business in the Chemical Process Industries (CPI) is not local, it's global. To keep up with this rapidly evolving marketplace, you need a magazine that covers it all, not just one country or region, not just one vertical market, but the entire CPI. With editorial offices around the world, Chemical Engineering is well-positioned to keep abreast of all the latest innovations in the equipment, technology, materials, and services used by process plants worldwide. No other publication even comes close.

To subscribe or learn more about membership, please visit www.chemengonline.com/subscribe

www.chemengonline.com

25430

11

PROCESS CHEMICALS

- | | |
|--|---|
| 107 Acids, amino | 107 Emulsifiers |
| 107 Acids, fatty | 107 Flame retardants |
| 107 Acids, organic | 107 Hydrogen |
| 107 Alcohols, other | 107 Inhibitors, corrosion |
| 107 Antioxidants | 107 Organic intermediates |
| 107 Biocides, halogenated | 107 Pigments |
| 107 Biocides, other | 107 Preservatives |
| 107 Catalyst supports & systems | 107 Resins, water-soluble |
| 107 Catalysts, custom | 107 Solvents, oxygenated |
| 107 Catalysts, desulfurization | 108 Surface active agents, not further specified |
| 107 Catalysts, polymerization | 108 Water treatment chemicals |
| 107 Dispersing agents, leather | 108 Zeolites |
| 107 Dispersing agents, other | |
| 107 Dispersing agents, rubber | |

Acids, amino

ARKEMA INC., 900 First Avenue, King of Prussia, PA 19406 (610-205-7000; FAX: 610-205-7913)
— See our ad on page 3

Acids, fatty

Agriculture silicoen adjuvant, Jiujiang, Jiangxi, China
ARKEMA INC., 900 First Avenue, King of Prussia, PA 19406 (610-205-7000; FAX: 610-205-7913)
— See our ad on page 3

Acids, organic

HighChem Co. Ltd, Japan

Alcohols, other

HighChem Co. Ltd, Japan

Antioxidants

ARKEMA INC., 900 First Avenue, King of Prussia, PA 19406 (610-205-7000; FAX: 610-205-7913)
— See our ad on page 3

LANXESS CORPORATION, 111 RIDC Park West Drive, Pittsburgh, PA 15275 (412-809-1000; info@lanxess.com; www.lanxess.us)

Biocides, halogenated

LANXESS CORPORATION, 111 RIDC Park West Drive, Pittsburgh, PA 15275 (412-809-1000; info@lanxess.com; www.lanxess.us)

Biocides, other

LANXESS CORPORATION, 111 RIDC Park West Drive, Pittsburgh, PA 15275 (412-809-1000; info@lanxess.com; www.lanxess.us)

Catalyst supports & systems

SAINT-GOBAIN NORPRO CORP., 3840 Fishcreek Road, Stow, OH 44224 (330-673-5860; FAX: 330-677-7245; www.saintgobain.com)

Catalysts, custom

SAINT-GOBAIN NORPRO CORP., 3840 Fishcreek Road, Stow, OH 44224 (330-673-5860; FAX: 330-677-7245; www.saintgobain.com)

Catalysts, desulfurization

HighChem Co. Ltd, Japan

Catalysts, polymerization

LANXESS CORPORATION, 111 RIDC Park West Drive, Pittsburgh, PA 15275 (412-809-1000; info@lanxess.com; www.lanxess.us)

Dispersing agents, leather

LANXESS CORPORATION, 111 RIDC Park West Drive, Pittsburgh, PA 15275 (412-809-1000; info@lanxess.com; www.lanxess.us)

Dispersing agents, other

AOC Resins, Collierville, TN

Dispersing agents, rubber

LANXESS CORPORATION, 111 RIDC Park West Drive, Pittsburgh, PA 15275 (412-809-1000; info@lanxess.com; www.lanxess.us)

Emulsifiers

LANXESS CORPORATION, 111 RIDC Park West Drive, Pittsburgh, PA 15275 (412-809-1000; info@lanxess.com; www.lanxess.us)

Flame retardants

ARKEMA INC., 900 First Avenue, King of Prussia, PA 19406 (610-205-7000; FAX: 610-205-7913)
— See our ad on page 3

LANXESS CORPORATION, 111 RIDC Park West Drive, Pittsburgh, PA 15275 (412-809-1000; info@lanxess.com; www.lanxess.us)

Hydrogen

NEL HYDROGEN, 10 Technology Drive, Wallingford, CT 06942 (203-949-8697; FAX: 203-949-8016)
THYSSENKRUPP INDUSTRIAL SOLUTIONS AG, thyssenkrupp Allee 1, Essen, Germany 45143 (49-201 8440; info.industrial-solutions@thyssenkrupp.com; www.thyssenkrupp-industrial-solutions.com)

Inhibitors, corrosion

ARKEMA INC., 900 First Avenue, King of Prussia, PA 19406 (610-205-7000; FAX: 610-205-7913)
— See our ad on page 3

LANXESS CORPORATION, 111 RIDC Park West Drive, Pittsburgh, PA 15275 (412-809-1000; info@lanxess.com; www.lanxess.us)

Organic intermediates

LANXESS CORPORATION, 111 RIDC Park West Drive, Pittsburgh, PA 15275 (412-809-1000; info@lanxess.com; www.lanxess.us)

Pigments

AOC Resins, Collierville, TN
HighChem Co. Ltd, Japan
LANXESS CORPORATION, 111 RIDC Park West Drive, Pittsburgh, PA 15275 (412-809-1000; info@lanxess.com; www.lanxess.us)

Preservatives

LANXESS CORPORATION, 111 RIDC Park West Drive, Pittsburgh, PA 15275 (412-809-1000; info@lanxess.com; www.lanxess.us)

Resins, water-soluble

AOC Resins, Collierville, TN

Solvents, oxygenated

ARKEMA INC., 900 First Avenue, King of Prussia, PA 19406 (610-205-7000; FAX: 610-205-7913)
— See our ad on page 3

Surface active agents, not further specified

HighChem Co. Ltd, Japan

Water treatment chemicals

ARKEMA INC., 900 First Avenue, King of Prussia, PA 19406 (610-205-7000; FAX: 610-205-7913)

— See our ad on page 3

LANXESS CORPORATION, 111 RIDC Park West Drive, Pittsburgh, PA 15275 (412-809-1000; info@lanxess.com; www.lanxess.us)

Zeolites

ARKEMA INC., 900 First Avenue, King of Prussia, PA 19406 (610-205-7000; FAX: 610-205-7913)

— See our ad on page 3



HYDROGENEXT

Your event for the emerging H₂ economy

SAVE THE DATE

October 3-6, 2022

Gaylord Rockies | Denver, Colorado

Co-located with Experience POWER & the Distributed Energy Conference



The one event covering the full value chain from hydrogen production to distribution and end-use for the energy and chemical process industries.

HydrogeNext is powered by:



HIGH SHEAR MIXERS

World's Widest Selection,
Single Stage to Ultra-High Shear!



Scan to learn more.

Try our mobile app:
mixers.com/web-app

1-800-243-ROSS

www.HighShearMixers.com



For details visit
adlinks.chemengonline.com/80076-241

Vesconite Hilube
solves vertical
pump
bushing
problems



- Low friction
- No swell
- Increase MTBR
- Quick supply

CALL FOR SAMPLE

Toll Free 866-635-7596
vesconite@vesconite.com
www.vesconite.com

For details visit
adlinks.chemengonline.com/80076-243

HEAT EXCHANGERS



◀ Liquid Cooled

Air Cooled ▶

FOR GASES & LIQUIDS!

Talk Directly with Design Engineers!
Blower Cooling Vent Condensing

INDUSTRIAL HEAT EXCHANGERS
XCHANGER

(952) 933-2559 info@xchanger.com

For details visit
adlinks.chemengonline.com/80076-245



PROCESS EQUIPMENT MANUFACTURING

BLOW TANK



952.492.5669
Alloyhardfacing.com
salesinfo@alloyhardfacing.net

For details visit
adlinks.chemengonline.com/80076-240

**Moisture
Degrading Your
Conveyed Materials?**

**We Have
The
Solution!**

Talk Directly with Design Engineers!
Blower Aftercoolers Dehumidifiers

INDUSTRIAL HEAT EXCHANGERS
XCHANGER

(952) 933-2559 info@xchanger.com

For details visit
adlinks.chemengonline.com/80076-244

**Barcoding on the
shop floor?**

- ★ Time
- ★ Materials
- ★ WIP

**I'll show you how!
Standard Time®**

stdtime.com/shop-floor **st**



For details visit
adlinks.chemengonline.com/80076-242

**ADVERTISE IN THE
CLASSIFIEDS**

Contact your Sales Representative for More Information:

JASON BULLOCK | bullock@chemengonline.com
713-974-0911

TERRY DAVIS | tdavis@chemengonline.com
404-434-5123

PETRA TRAUTES | ptrautes@accessintel.com
+49 49 58604760

Let's make 2021 better*

Upgrade now to GOLD membership
and get **all** of Chemical Engineering
+ archives + podcasts + exclusive
video + 50% off in the bookstore
+ much more!

www.chemengonline.com/gold

* and 2022 and 2023 and ...



Advertising Sales Representatives

North America

Matthew Grant | VP & Group Publisher

mgrant@accessintel.com

Jason Bullock, CBC | District Sales Manager

Tel: 713-974-0911 | E-mail: jbullock@chemengonline.com
Chemical Engineering 1940 Fountain View #514 Houston, TX
77057

Alabama, Alaska, Arizona, Arkansas, California,
Colorado, Florida, Idaho, Hawaii, Idaho, Illinois, Indiana,
Iowa, Kansas, Kentucky, Louisiana, Michigan, Minnesota,
Mississippi, Montana, Missouri, Nebraska, Nevada, New
Mexico, North Carolina, North Dakota, Ohio, Oklahoma,
Oregon, South Carolina, South Dakota, Tennessee, Texas,
Utah, Virginia, West Virginia, Wyoming, Washington,
Wisconsin

Terry Davis | District Sales Manager

Tel: 404-634-5123 | E-mail: tdavis@accessintel.com
Chemical Engineering 2276 Eastway Rd., Decatur, GA 30033
Connecticut, District Of Columbia, Delaware, Georgia,
Maine, Maryland, Massachusetts, New Hampshire, New
Jersey, New York, Pennsylvania, Rhode Island, Vermont,
Canada, Latin America

International

Petra Trautes

Tel: +49-69-58604760 | Fax: +49-69-5700-2484
Email: ptroutes@chemengonline.com
Chemical Engineering Zeilweg 44 D-60439 Frankfurt am
Main Germany
Austria, Czech Republic, Benelux, Eastern Europe,
Germany, Scandinavia, Switzerland, United Kingdom

Dipali Dhar

Tel: 718-263-1162 | E-mail: ddhar@accessintel.com
Chemical Engineering 40 Wall Street, 16th Floor, New York,
NY 10005
India

Katshuhiro Ishii

Tel: 81-3-5691-3335; Fax: 81-3-5691-3336
E-mail: amskatsu@dream.com
Chemical Engineering Ace Media Service Inc., 12-6,
4-chome Nishiiko, Adachi-ku, Tokyo 121, Japan
Japan

Ferruccio Silvera

Tel: 39-02-284-6716 | Fax: 39-02-289-3849
E-mail: ferruccio@silvera.it/www.silvera.it
Chemical Engineering Silvera Pubblicita Viale Monza,
24 Milano 20127, Italy
Andorra, France, Gibraltar, Greece, Israel, Italy,
Portugal, Spain

Rudy Teng

Tel: +86 13818181202, (China) | +886 921322428
(Taiwan) | Fax: +86 21 54183567
E-mail: rudy.teng@gmail.com
Chemical Engineering 8F-1 #181 Wulin Road Hsinchu
30055 Taiwan
Asia-Pacific, Hong Kong, People's Republic of
China, Taiwan

Advertisers Index

Advertiser.....	Page number	Advertiser.....	Page number	Advertiser.....	Page number
Phone number	Reader Service #	Phone number	Reader Service #	Phone number	Reader Service #
Abbe, Paul O.....	15	GEMCO.....	16	Myron L Company.....	20
1-855-789-9827		1-800-654-3626		adlinks.chemengonline.com/80076-10	
adlinks.chemengonline.com/80076-07		adlinks.chemengonline.com/80076-09			
ACHEMA 2022.....	22	INDECK Power.....	15	Plast-O-Matic Valves, Inc.....	33
www.achema.de		1-800-446-3325		973-256-3000	
		adlinks.chemengonline.com/80076-08		adlinks.chemengonline.com/80076-12	
AMERICAN		KOCH Engineered		Pompetravaini Spa.....	47
ELEMENTS.....	CV4, 52	Solutions.....	CV2	+39 0331 889000	
adlinks.chemengonline.com/80076-15		adlinks.chemengonline.com/80076-01		adlinks.chemengonline.com/80076-19	
ANIVI Ingenieria, S.L.....	55	Koerting Hannover.....	69	Ross Mixers.....	7
+34 94 453 19 00		+49 511 2129-0		1-800-243-ROSS	
www.anivi.com		adlinks.chemengonline.com/80076-17		adlinks.chemengonline.com/80076-03	
ARKEMA.....	3	Komline.....	67	Schenck Process.....	45
adlinks.chemengonline.com/80076-02		1-800-call-4-ks		adlinks.chemengonline.com/80076-23	
		adlinks.chemengonline.com/80076-18		TLV Corporation.....	54, 65
Beltran Technologies.....	45	Load Controls.....	12	adlinks.chemengonline.com/80076-20	
adlinks.chemengonline.com/80076-24		1-888-600-3247		Uniflex/Exotherm.....	53, 57
Chemstations.....	9	adlinks.chemengonline.com/80076-06		adlinks.chemengonline.com/80076-21	
adlinks.chemengonline.com/80076-04		MAAG Group.....	41		
Chemours.....	10	adlinks.chemengonline.com/80076-14			
adlinks.chemengonline.com/80076-05		Metso:Outotec.....	39		
Connected Plant		760-438-2021			
Conference 2022.....	CV3	adlinks.chemengonline.com/80076-13			
www.connectedplantconference.com					
Durr Systems.....	43				
adlinks.chemengonline.com/80076-22					
Ekato Process					
Technologies GmbH.....	84				
1-201-825-4684 x205					
adlinks.chemengonline.com/80076-16					
GEA Wiegand GmbH.....	23				
adlinks.chemengonline.com/80076-11					

Classified Index December 2021

New & Used Equipment 109

Advertiser	Page number	Advertiser	Page number
Phone number	Reader Service #	Phone number	Reader Service #
Alloy Hard Facing.....	109	Vesconite Bearings.....	109
952-492-5669		1-866-635-7596	
adlinks.chemengonline.com/80076-240		adlinks.chemengonline.com/80076-243	
Ross Mixers.....	109	Xchanger.....	109
1-800-243-ROSS		952-933-2559	
adlinks.chemengonline.com/80076-241		adlinks.chemengonline.com/80076-244	
Scoutwest.....	109	adlinks.chemengonline.com/80076-245	
adlinks.chemengonline.com/80076-242			

See bottom of opposite page
for advertising
sales representatives'
contact information

FOR ADDITIONAL NEWS AS IT DEVELOPS, PLEASE VISIT WWW.CHEMENGONLINE.COM

December 2021: VOL. 128: NO. 12

Chemical Engineering copyright © 2021 (ISSN 0009-2460) is published monthly by Access Intelligence, LLC, 9211 Corporate Blvd., 4th Floor, Rockville, MD 20850. Chemical Engineering Executive, Editorial and Publication Office: 40 Wall Street, 16th Floor, New York, NY 10005. Phone: 212-621-4694. Subscription rates: U.S. and possessions 1-year \$199.97, 2-years \$359.00, Canada and International 1-year \$399.97, 2-years \$719.00. Back Issues & Single Copy Sales \$59.00 per copy. Periodical postage paid at Rockville, MD and additional mailing offices. Postmaster: Send address changes to Chemical Engineering, 9211 Corporate Blvd., 4th Floor, Rockville, MD 20850. Phone: 1-800-777-5006, Fax: 301-309-3847, email: clientservices@accessintel.com. Change of address two to eight weeks notice requested. For information regards article reprints please contact Wright's Media, 1-877-652-5295, accessintel@wrightsmedia.com. Contents may not be reproduced in any form without permission. Canada Post 40612608. Return undeliverable Canadian Addresses to: The Mail Group, P.O. Box 25542 London, ON N6C 6B2 Canada.

Download the CEPCI two weeks sooner at www.chemengonline.com/pci

CHEMICAL ENGINEERING PLANT COST INDEX (CEPCI)

(1957-59 = 100)	Sept. '21 Prelim.	Aug. '21 Final	Sept. '20 Final	Annual Index:
CE Index	754.7	735.2	593.7	2013 = 567.3
Equipment	947.5	918.6	717.2	2014 = 576.1
Heat exchangers & tanks	813.2	784.8	605.8	2015 = 556.8
Process machinery	958.5	921.1	717.9	2016 = 541.7
Pipe, valves & fittings	1,330.9	1,304.7	954.0	2017 = 567.5
Process instruments	551.3	541.3	422.1	2018 = 603.1
Pumps & compressors	1,180.5	1,148.8	1,084.0	2019 = 607.5
Electrical equipment	639.3	616.8	565.0	2020 = 596.2
Structural supports & misc.	1,038.9	1,000.4	752.7	
Construction labor	348.6	347.4	337.6	
Buildings	772.0	767.5	616.1	
Engineering & supervision	311.1	310.2	311.8	

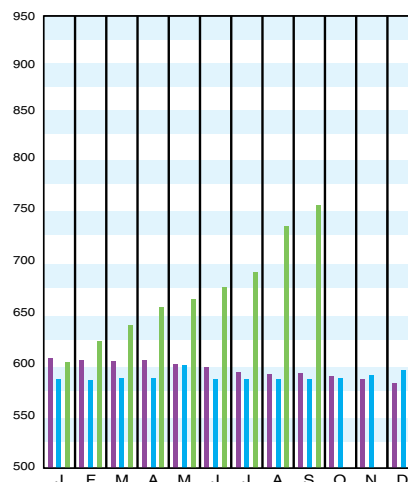

Starting in April 2007, several data series for labor and compressors were converted to accommodate series IDs discontinued by the U.S. Bureau of Labor Statistics (BLS). Starting in March 2018, the data series for chemical industry special machinery was replaced because the series was discontinued by BLS (see *Chem. Eng.*, April 2018, p. 76-77.)

CURRENT BUSINESS INDICATORS

	LATEST	PREVIOUS	YEAR AGO
CPI output index (2017 = 100)	Oct. '21 = 98.5	Sept. '21 = 97.3	Oct. '20 = 93.9
CPI value of output, \$ billions	Sept. '21 = 2,005.4	Aug. '21 = 1,984.9	Sept. '20 = 1,672.2
CPI operating rate, %	Oct. '21 = 78.5	Sept. '21 = 77.6	Oct. '20 = 74.6
Producer prices, industrial chemicals (1982 = 100)	Oct. '21 = 335.4	Sept. '21 = 345.2	Oct. '20 = 227.7
Industrial Production in Manufacturing (2017 = 100)*	Oct. '21 = 99.8	Sept. '21 = 98.6	Oct. '20 = 95.6
Hourly earnings index, chemical & allied products (1992 = 100)	Oct. '21 = 195.9	Sept. '21 = 198.3	Oct. '20 = 188.6
Productivity index, chemicals & allied products (1992 = 100)	Oct. '21 = 95.4	Sept. '21 = 94.4	Oct. '20 = 90.4

CPI OUTPUT INDEX (2017 = 100)†

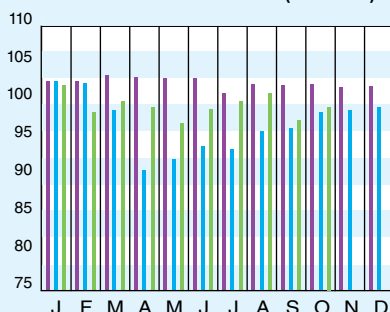

CPI OUTPUT VALUE (\$ BILLIONS)

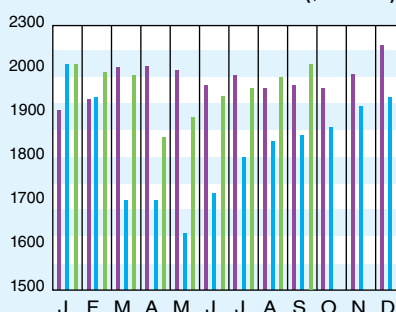

CPI OPERATING RATE (%)

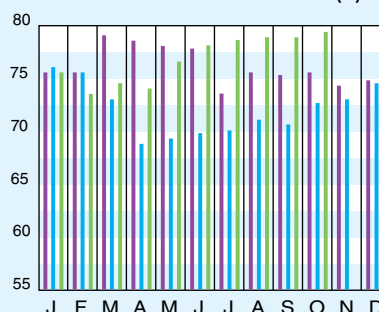

*Due to discontinuance, the Index of Industrial Activity has been replaced by the Industrial Production in Manufacturing index from the U.S. Federal Reserve Board.
†For the current month's CPI output index values, the base year was changed from 2012 to 2017.
Current business indicators provided by Global Insight, Inc., Lexington, Mass.

CURRENT TRENDS

The preliminary value for the CE Plant Cost Index (CEPCI; top) for September 2021 (most recent available) continues the streak of rapid monthly increases observed since the beginning of the year. The Index topped 750, after beginning the year at around 600. In September, all four major subindices (Equipment, Construction Labor, Buildings and Engineering & Supervision) saw upticks, with the Equipment subindex showing the largest gain. The current CEPCI value is 27.1% higher than the corresponding value from September 2020. Meanwhile, the Current Business Indicators (middle) show rises in the CPI Output Index and the CPI Operating Rate for October 2021, and a rise in the CPI Value of Output for September.

Hot Topics in the Chemical Processing Industry

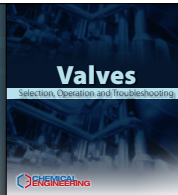

Valves Selection: Operation and Troubleshooting

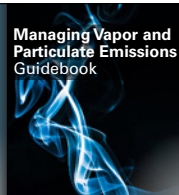

Optimal Pump Management

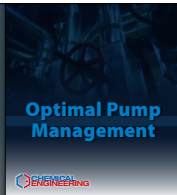

Managing Vapor and Particulate Emissions



Find these and other related CPI titles in the Chemical Engineering Store. store.chemengonline.com

6TH ANNUAL



CONNECTED PLANT CONFERENCE

Harnessing Digital Tools to Drive Success

SAVE THE DATE

May 23-26, 2022

Renaissance Waverly Hotel | Atlanta, GA

The only event covering digitalization for the power and chemical process industries returns to Atlanta to bring the who's who of both industries together to explore the fast-paced advances in automation, data analytics, computing networks, "smart" sensors, augmented reality, and other digital technologies to improve plant processes and operations.

Get more from your investments, speed up your response, and keep up with technology advancements and changes at the Connected Plant Conference.

Technology advances at warp speed...don't get left behind!

Hosted by:

POWER
BUSINESS & TECHNOLOGY FOR THE GLOBAL GENERATION INDUSTRY SINCE 1882

**CHEMICAL
ENGINEERING**
ESSENTIALS FOR THE CPI PROFESSIONAL

connectedplantconference.com
[@connectedplant](https://twitter.com/connectedplant) | [#connectedplant](https://twitter.com/connectedplant)



THE ADVANCED MATERIALS MANUFACTURER®

1 H 1.00794 Hydrogen																	2 He 4.002602 Helium
3 Li 6.941 Lithium	4 Be 9.012182 Beryllium											5 B 10.811 Boron	6 C 12.0107 Carbon	7 N 14.0064 Nitrogen	8 O 15.999 Oxygen	9 F 18.9984032 Fluorine	10 Ne 20.1797 Neon
11 Na 22.98976928 Sodium	12 Mg 24.304 Magnesium											13 Al 26.9815386 Aluminum	14 Si 28.0855 Silicon	15 P 30.973762 Phosphorus	16 S 32.065 Sulfur	17 Cl 35.453 Chlorine	18 Ar 39.948 Argon
19 K 39.0983 Potassium	20 Ca 40.078 Calcium	21 Sc 44.955912 Scandium	22 Ti 47.88 Titanium	23 V 50.9415 Vanadium	24 Cr 51.9961 Chromium	25 Mn 54.938045 Manganese	26 Fe 55.845 Iron	27 Co 58.933196 Cobalt	28 Ni 58.6934 Nickel	29 Cu 63.546 Copper	30 Zn 65.38 Zinc	31 Ga 69.723 Gallium	32 Ge 72.64 Germanium	33 As 74.9216 Arsenic	34 Se 78.96 Selenium	35 Br 79.904 Bromine	36 Kr 83.798 Krypton
37 Rb 85.4678 Rubidium	38 Sr 87.62 Strontium	39 Y 88.90585 Yttrium	40 Zr 91.224 Zirconium	41 Nb 92.90638 Niobium	42 Mo 95.96 Molybdenum	43 Tc 98.90625 Technetium	44 Ru 101.07 Ruthenium	45 Rh 102.9055 Rhodium	46 Pd 106.42 Palladium	47 Ag 107.8682 Silver	48 Cd 112.411 Cadmium	49 In 114.818 Indium	50 Sn 118.710 Tin	51 Sb 121.757 Antimony	52 Te 127.6 Tellurium	53 I 126.90547 Iodine	54 Xe 131.29 Xenon
55 Cs 132.90545196 Cesium	56 Ba 137.327 Barium	57 La 138.90547 Lanthanum	58 Ce 140.12 Cerium	59 Pr 140.90766 Praseodymium	60 Nd 144.242 Neodymium	61 Pm 144.91288 Promethium	62 Sm 150.36 Samarium	63 Eu 151.964 Europium	64 Gd 157.25 Gadolinium	65 Tb 158.92535 Terbium	66 Dy 162.5 Dysprosium	67 Ho 164.93033 Holmium	68 Er 167.259 Erbium	69 Tm 168.93274 Thulium	70 Yb 173.054 Ytterbium	71 Lu 174.967 Lutetium	
87 Fr 223 Francium	88 Ra 226 Radium	89 Ac 227 Actinium	90 Th 232.0377 Thorium	91 Pa 231.036888 Protactinium	92 U 238.02891 Uranium	93 Np 237.0481733 Neptunium	94 Pu 239.0521634 Plutonium	95 Am 243.061381 Americium	96 Cm 247.070351 Curium	97 Bk 247.070351 Berkelium	98 Cf 251.079589 Californium	99 Es 252.083223 Einsteinium	100 Fm 257.1037566 Fermium	101 Md 258.1037566 Mendelevium	102 No 259.1037566 Nobelium	103 Lr 260.1037566 Lawrencium	

58 Ce 140.116 Cerium	59 Pr 140.90766 Praseodymium	60 Nd 144.242 Neodymium	61 Pm 144.91288 Promethium	62 Sm 150.36 Samarium	63 Eu 151.964 Europium	64 Gd 157.25 Gadolinium	65 Tb 158.92535 Terbium	66 Dy 162.5 Dysprosium	67 Ho 164.93033 Holmium	68 Er 167.259 Erbium	69 Tm 168.93274 Thulium	70 Yb 173.054 Ytterbium	71 Lu 174.967 Lutetium
90 Th 232.0377 Thorium	91 Pa 231.036888 Protactinium	92 U 238.02891 Uranium	93 Np 237.0481733 Neptunium	94 Pu 239.0521634 Plutonium	95 Am 243.061381 Americium	96 Cm 247.070351 Curium	97 Bk 247.070351 Berkelium	98 Cf 251.079589 Californium	99 Es 252.083223 Einsteinium	100 Fm 257.1037566 Fermium	101 Md 258.1037566 Mendelevium	102 No 259.1037566 Nobelium	103 Lr 260.1037566 Lawrencium

Now Invent.™

The Next Generation of Material Science Catalogs

Over 35,000 certified high purity laboratory chemicals, metals, & advanced materials and a state-of-the-art Research Center. Printable GHS-compliant Safety Data Sheets. Thousands of new products. And much more. All on a secure multi-language "Mobile Responsive" platform.

American Elements opens a world of possibilities so you can Now Invent!

www.americanelements.com